

**Tutorials:
Character-Animation**

**Autodesk®
3ds Max®**

2010



Autodesk®

Autodesk® 3ds® Max 2010 Software

© 2009 Autodesk, Inc. All rights reserved. Except as otherwise permitted by Autodesk, Inc., this publication, or parts thereof, may not be reproduced in any form, by any method, for any purpose.

Certain materials included in this publication are reprinted with the permission of the copyright holder.

The following are registered trademarks or trademarks of Autodesk, Inc., in the USA and other countries: 3DEC (design/logo), 3December, 3December.com, 3ds Max, ADI, Alias, Alias (swirl design/logo), AliasStudio, AliasWavefront (design/logo), ATC, AUGI, AutoCAD, AutoCAD Learning Assistance, AutoCAD LT, AutoCAD Simulator, AutoCAD SQL Extension, AutoCAD SQL Interface, Autodesk, Autodesk Envision, Autodesk Insight, Autodesk Intent, Autodesk Inventor, Autodesk Map, Autodesk MapGuide, Autodesk Streamline, AutoLISP, AutoSnap, AutoSketch, AutoTrack, Backdraft, Built with ObjectARX (logo), Burn, Buzzsaw, CAICE, Can You Imagine, Character Studio, Cinestream, Civil 3D, Cleaner, Cleaner Central, ClearScale, Colour Warper, Combustion, Communication Specification, Constructware, Content Explorer, Create>what's>Next> (design/logo), Dancing Baby (image), DesignCenter, Design Doctor, Designer's Toolkit, DesignKids, DesignProf, DesignServer, DesignStudio, DesignStudio (design/logo), Design Web Format, Discreet, DWF, DWG, DWG (logo), DWG Extreme, DWG TrueConvert, DWG TrueView, DXF, Ecotect, Exposure, Extending the Design Team, Face Robot, FBX, Filmbox, Fire, Flame, Flint, FMDesktop, Freewheel, Frost, GDX Driver, Gmax, Green Building Studio, Heads-up Design, Heidi, HumanIK, IDEA Server, i-drop, ImageModeler, iMOUT, Incinerator, Inferno, Inventor, Inventor LT, Kaydara, Kaydara (design/logo), Kynapse, Kynogon, LandXplorer, LocationLogic, Lustre, Matchmover, Maya, Mechanical Desktop, Moonbox, MotionBuilder, Movimento, Mudbox, NavisWorks, ObjectARX, ObjectDBX, Open Reality, Opticore, Opticore Opus, PolarSnap, PortfolioWall, Powered with Autodesk Technology, Productstream, ProjectPoint, ProMaterials, RasterDWG, Reactor, RealDWG, Real-time Roto, REALVIZ, Recognize, Render Queue, Retimer, Reveal, Revit, Showcase, ShowMotion, SketchBook, Smoke, Softimage, Softimage|XSI (design/logo), SteeringWheels, Stitcher, Stone, StudioTools, Topobase, Toxik, TrustedDWG, ViewCube, Visual, Visual Construction, Visual Drainage, Visual Landscape, Visual Survey, Visual Toolbox, Visual LISP, Voice Reality, Volo, Vtour, Wire, Wiretap, WiretapCentral, XSI, and XSI (design/logo).

Trademarks

The following are registered trademarks or trademarks of Autodesk Canada Co. in the USA and/or Canada and other countries: Backburner, Multi-Master Editing, River, and Sparks.

The following are registered trademarks or trademarks of Moldflow Corp. in the USA and/or other countries: Moldflow MPA, MPA (design/logo), Moldflow Plastics Advisers, MPI, MPI (design/logo), Moldflow Plastics Insight, MPX, MPX (design/logo), Moldflow Plastics Xpert.

clothfx™ is a trademark of Size8 Software, Inc. Havok.com™ is a trademark or registered trademark of Havok.com Inc. or its licensors. Intel is a registered trademark of Intel Corporation. mental ray is a registered trademark of mental images GmbH licensed for use by Autodesk, Inc. All other brand names, product names or trademarks belong to their respective holders.

Disclaimer

THIS PUBLICATION AND THE INFORMATION CONTAINED HEREIN IS MADE AVAILABLE BY AUTODESK, INC. "AS IS." AUTODESK, INC. DISCLAIMS ALL WARRANTIES, EITHER EXPRESS OR IMPLIED, INCLUDING BUT NOT LIMITED TO ANY IMPLIED WARRANTIES OF MERCHANTABILITY OR FITNESS FOR A PARTICULAR PURPOSE REGARDING THESE MATERIALS.

Character-Animation Tutorials

5

The following tutorials introduce you to the fundamentals of character animation using 3ds Max 's biped system. You will learn how to create and control a virtual skeleton, which will drive the motion of your character.

Features Covered in This Section

- Adjusting your biped with Figure Mode.
- Applying Physique.
- Creating a walk cycle using Footsteps.
- Creating and editing a generated walk cycle using Footsteps.
- Setting keys in freeform mode.
- Combining animation clips to create an animated sequence.
- IK linking different biped limbs to objects.
- Animating multi-legged creatures.

Biped Quickstart

This tutorial introduces you to the elements of the built-in character animation features in 3ds Max and the workflow for some of its most important features.



In this tutorial, you will learn how to:

- Create and pose a biped.
- Associate the biped with a mesh using the Physique modifier.
- Animate the biped using two different methods, freeform and footstep animation.
- Combine motions in the Motion Mixer.

Skill level: Beginner

Time to complete: 1 hour

Creating a Biped

In this lesson, you'll create a default biped: a simple skeleton consisting of bones connected in a hierarchy. A default biped is different from 3ds Max Bone system objects because the biped structure automatically has built-in joints like a human being. You can bend your knee so your foot touches the back of your thigh, but you can't bend it forward so that your toe touches the front of your thigh. Biped creates skeletons in the same fashion. They are ready to animate, and work accurately without additional setup .

Set up the lesson:

- Reset 3ds Max.

Create a biped:



- 1 On the Create panel, click Systems.



- 2 On the Object Type rollout, click Biped.

The Biped button turns gold.

- 3 If you can't see the Height spinner in the Create Biped rollout, scroll to the bottom of the command panel.
- 4 In the Perspective viewport, place your cursor over the center of the grid, press and hold the left mouse button, and drag upward.
A biped appears and grows with your cursor movement.
- 5 Drag upward until the Height spinner on the Create Biped rollout reads approximately 70 units, then release the mouse button.
A biped is created in the viewport.

The biped is a hierarchy of special objects. Its parent object (*Bip01*) is its center of mass (COM). The COM is displayed in the viewports as a small, blue tetrahedron, initially centered in the biped's pelvis. After you create a biped, only the center of mass object is selected (not the entire biped).

Name the biped:

When you create your first biped, it has a root name of *Bip01*. The root name of each additional biped is incremented, so the next biped you create has a

Posing a Biped

Once you've created a biped, you need to pose it to match the character model that the biped will control. This is done in Figure mode, which allows you to bend, rotate, and scale parts of the biped to conform to the character mesh. In this lesson, you will adjust a biped to fit a character mesh.

Character meshes are usually built in one of two stances. The most common is with the arms out and the legs slightly spread, like da Vinci's drawing of the Vitruvian Man. Or, the character mesh is built in a resting position with arms at its sides and legs together.

For this lesson, you'll be working with a character named Dr. X.

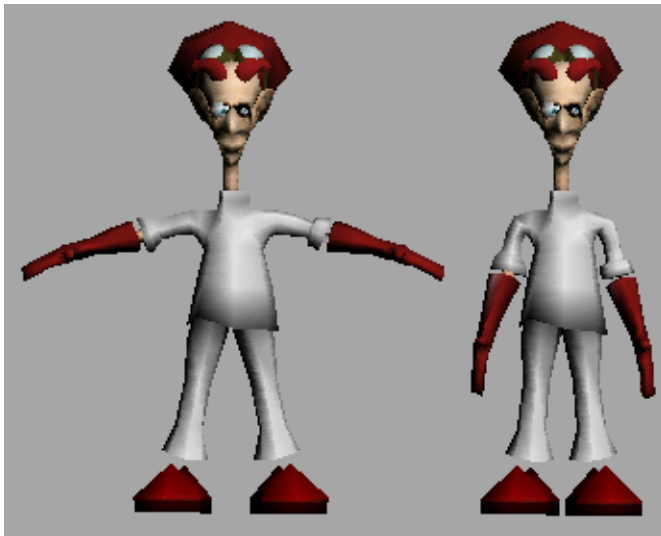

Left: Dr. X exhibiting the Vitruvian Man stance; right: a resting position.



Set up the lesson:

- 1 Reset 3ds Max.
- 2  On the Quick Access toolbar, click the Open File button, navigate to the `\animation\character_animation\quick_start` folder, and open `cs4_qs_DrX01.max`.

This scene contains a character mesh named *DoctorX*.

Build the biped:

Now that you know how to create a biped, you're going to use the character mesh as a template for building the biped that will control Dr. X.

- 1  On the Create panel, click Systems.
- 2  Turn on Biped and make sure you can see the Height spinner in the Create Biped rollout.
- 3 In the Front viewport, click down at Dr. X's feet and drag up until the biped is about **1.0m** in height
This will place the center of mass (COM) roughly at Dr. X's pelvis.

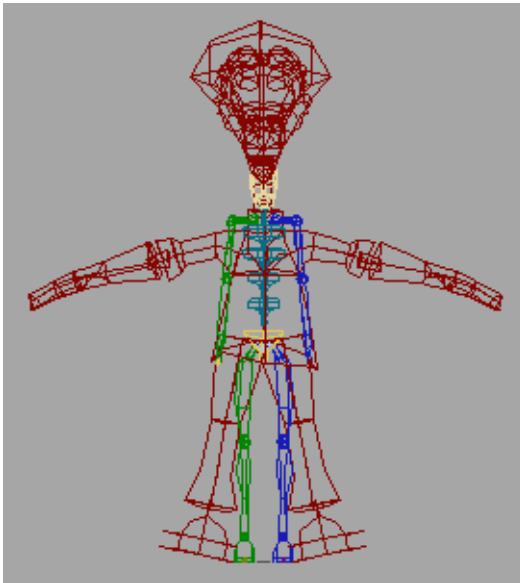

The new biped and Dr. X.

- 4 In the Create Biped rollout, change the Root Name to **Dr. X**.

NOTE When you change the name on the Create Biped rollout, the name is used as a prefix for all the biped's component parts; for example, *Dr. X L Foot*. If you use the usual Name And Color rollout, only the name of the biped's COM is changed; all other parts remain prefixed with *Biped01* (or whatever the current sequence number is).

Position the biped:

Once the biped is added to the character mesh, you need to adjust the biped to better match the stance of the mesh. First, you'll adjust the position of the biped within the Dr. X model.



1 Click the Motion panel tab.



2 In the Biped rollout, turn on Figure Mode.

All changes to the biped's reference pose must be done in Figure mode.



3 In the Left and Front viewports, click Zoom Region and zoom in around the pelvis of Dr. X.

The illustrations show the COM in white and arrows pointing at the center line of the mesh.

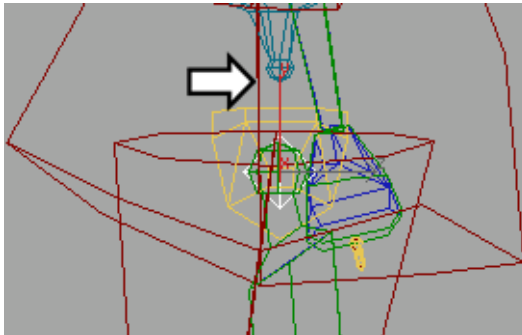

Zoom into Left viewport

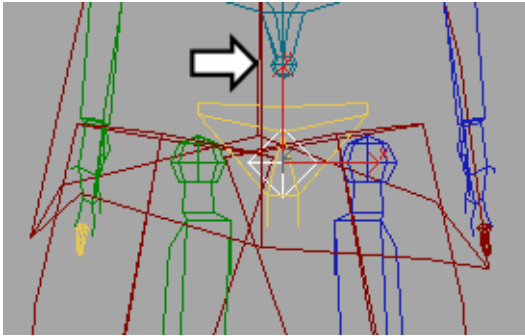

Zoom into Front viewport

- 4  In the Track Selection Rollout, make sure the Body Horizontal button is active.

- 5  Move *Dr.X*, the COM, in both the Left and Front viewports so that it lines up with the vertical center line of the character mesh.



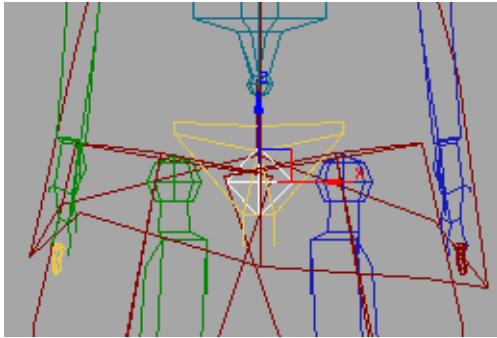

Bip01 moved in the Left viewport



Bip01 moved in the Front viewport

Adjust the legs:

Next, you'll adjust the legs so they conform with those of the character. When adjusting legs, you'll want to pay close attention to the key bend points at the knees and ankles.

- 1  Activate the Front viewport. Enlarge the viewport by pressing Alt+W on the keyboard and click the Zoom Extents button.
- 2  Select the biped's left thigh, *Dr.X L Thigh*. This is colored blue by default, and its name appears in the name field at the top of the Motion panel when selected.

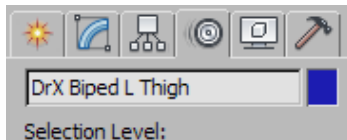

TIP If you select the mesh by mistake, deselect by clicking outside the figures, and then try again.

- 3  From the Track Selection rollout, click the Symmetrical button. The biped's right thigh, *Dr.X R Thigh* is now added to the selection set.

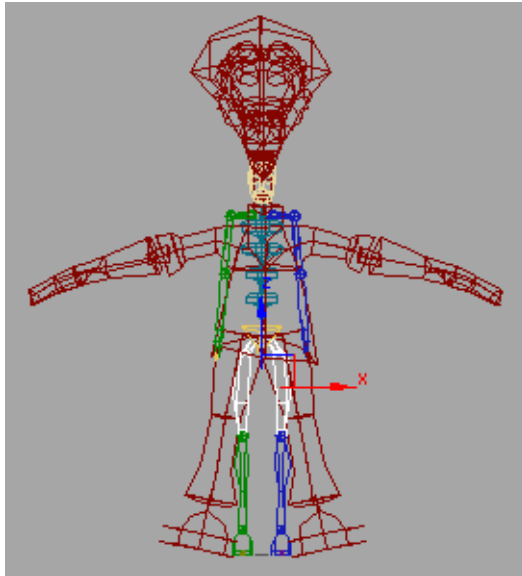

- 4 In this step, you rotate the biped's legs to run roughly along the legs of the mesh. To make these rotations, you'll have to switch between the Front and Left viewports. Press F and L on the keyboard to make these switches.



Click the Rotate button and make the following rotations:

- In the Front viewport, rotate about **12.0** degrees about the Z axis. A readout appears in yellow as you rotate the selection.

TIP Sometimes the legs will rotate in parallel, instead of in opposite directions. If this happens to you, select and rotate each leg individually.

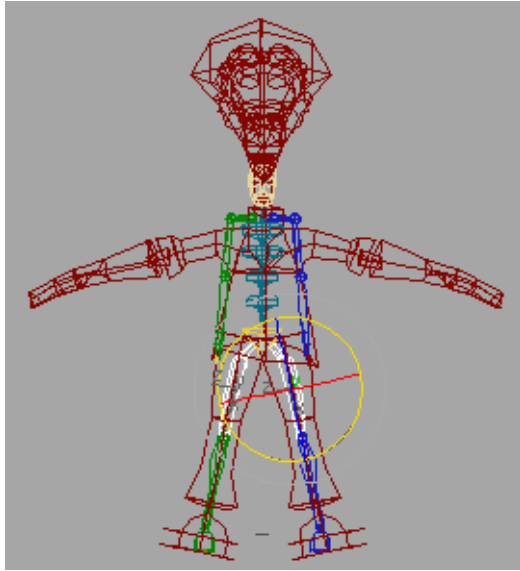

- In the Left viewport, rotate about **-8** degrees about the Z-axis.

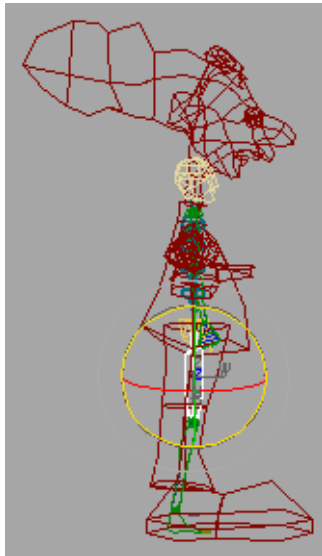



- 5 On the main toolbar, choose Select And Non-Uniform Scale. Scale the thighs along the X-axis until they match the skin model: about **85** percent. Type in the value or use the spinners while viewing the results in the viewport.

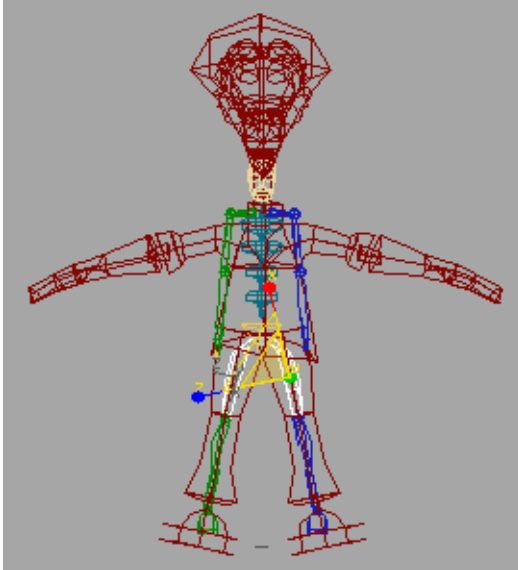

- 6 Press the Page Down key on the keyboard.
Page Up and Page Down are shortcuts for moving up and down the hierarchy. Since both thighs were selected, now both calves are selected after you press Page Down.
- 7 As you did with the thighs, scale the calves until they match the mesh: about **90** percent along the X axis.
This aligns the biped's ankles more closely with the ankles of the character mesh.

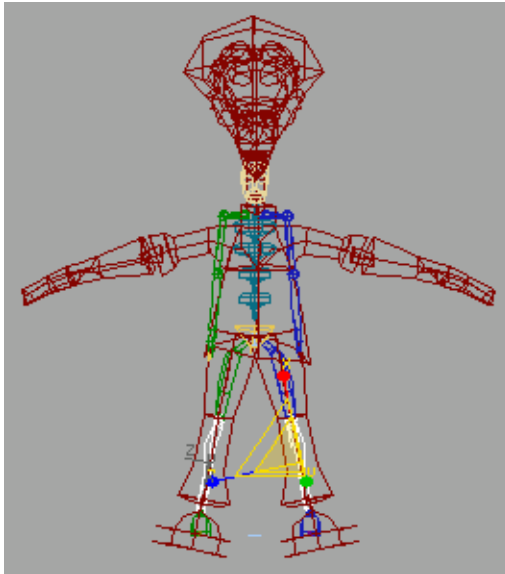

The Left view of the scaled thighs and calves.

- 8 Press Page Down again to select the biped feet. Scale the feet from the Front and Left views to more closely fit in the shoes.

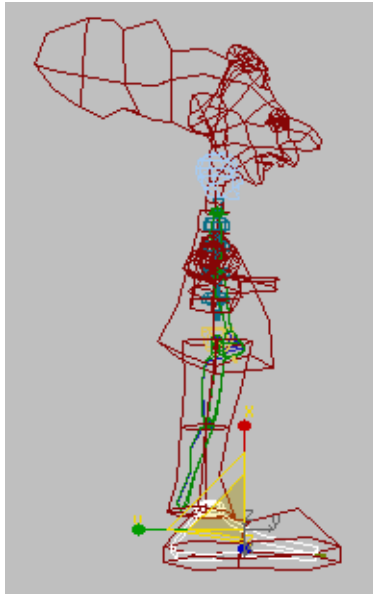

- 9 On the Structure rollout, adjust the Ankle attach value to slide the foot to better fit in the mesh: about **0.1**.

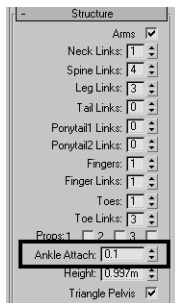

- 10 In the Front viewport, rotate the feet so they align with the mesh.

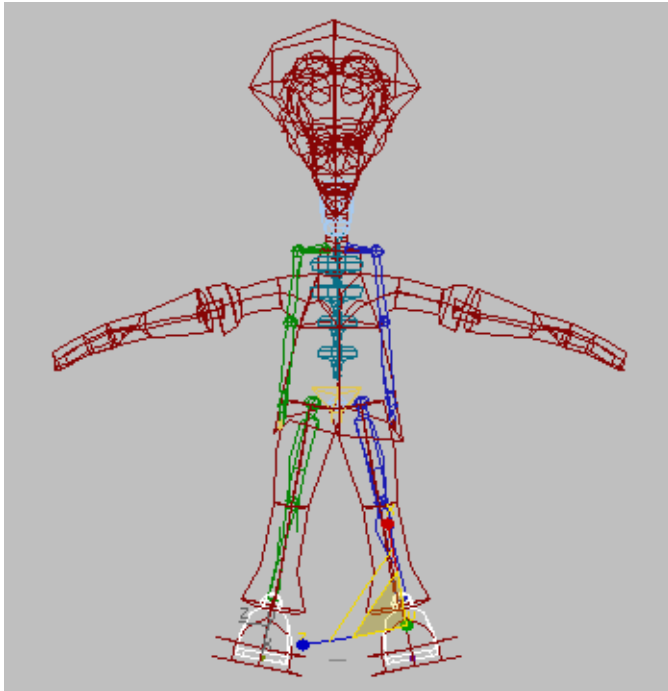

Rotate the feet to fit the mesh.

11 Save the scene as **my_drx01.max**.

The procedures you've just completed give you an idea of what it takes to align a biped to a mesh, and that patience is the key to this process. This character still needs work: the feet as well as the entire upper body must be adjusted. If you want, read the following tips for biped alignment, then use the same procedures to experiment with aligning the rest of the biped. Otherwise, continue to the next lesson.

Tips for Biped Alignment

Here are some tips that may help when adding a biped to a character mesh.

- The most important tip is to make sure the COM is always aligned with the mesh.

- When scaling and rotating biped parts, pay attention to the model in multiple viewports. A rotation, for instance, may look good in one viewport, but another viewport may indicate a problem.
- Examine the character mesh's complexity. If the character is wearing mittens or shoes, you probably don't need five fingers and toes. Adjust the biped structure accordingly.
- Remember ponytails. If the character has a lot of hair or a long nose, like an elephant trunk, you can use a ponytail to control that part of the mesh.
- If the character mesh has a short torso or long neck, it may be best to reduce the number of Spine Links or increase the number of Neck Links. You can add up to 25 links in the neck, tail or ponytails, and up to ten links in the spine.
- If the character is carrying something like a weapon or tool, add a Prop to control that object.

For a more detailed look at posing a biped, see the lesson [Aligning the Biped to the Model](#) on page 893.

Applying Physique

After the biped is posed to match the character mesh, you apply the Physique modifier to the character mesh. The Physique modifier associates the biped with the character mesh.

After Physique is applied and set up, any animation on the biped is passed on to the mesh, making it move as if there were bones and muscles underneath.

Set up the lesson:

- 1  On the Quick Access toolbar, click the Open File button, navigate to the `\animation\character_animation\quick_start` folder, and open `cs4_qs_drX02.max`.
This scene contains Dr. X and a completely posed biped.
- 2 In the Front viewport, zoom in on the biped's pelvis (orange triangle) and the center of mass, or COM (blue tetrahedron).

Apply Physique:

- 1 Select the character mesh, *DoctorX*.

- 2  On the Modify panel, choose Physique from the Modifier List. The Physique rollouts appear in the command panel.

- 3  In the Physique rollout, click Attach To Node, then click the biped's COM.

The Physique Initialization dialog displays.

- 4 Click Initialize.

The character mesh is now associated with the biped. The orange deformation spline running through the mesh indicates that the entire biped structure has been associated with the mesh.

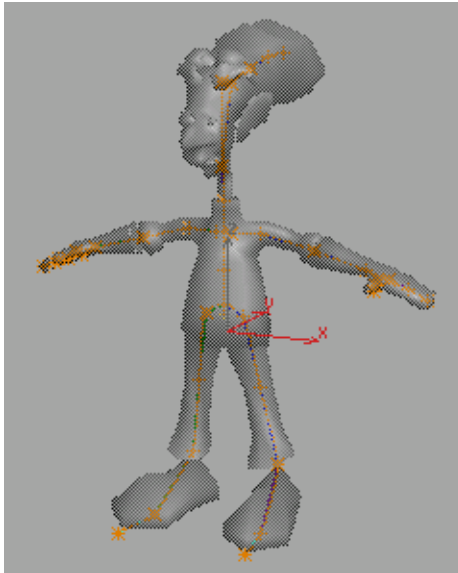

Orange spline follows Dr. X mesh. (This view uses See-Through display mode with the biped bones hidden.)

TIP To toggle the view to See-Through display mode, select the DoctorX mesh and press Alt+X.

Adjust the envelopes:

Physique associates the biped with the mesh by means of the mesh's vertices. Each biped part is surrounded by an area called an *envelope*, and mesh vertices that lie inside an envelope are effected by that biped part. The default size of an envelope depends on the size of the biped part, which you set when you pose the biped.

Often, envelopes must be manually adjusted to make the biped work properly with the mesh. If you notice irregular spikes poking out from the mesh, it's a good indication that one or more vertices lie outside of an envelope's area of influence. You can see this effect by rotating the arm.



- 1 Right-click the Top viewport to activate it and use Region Zoom to view Dr. X's left arm.

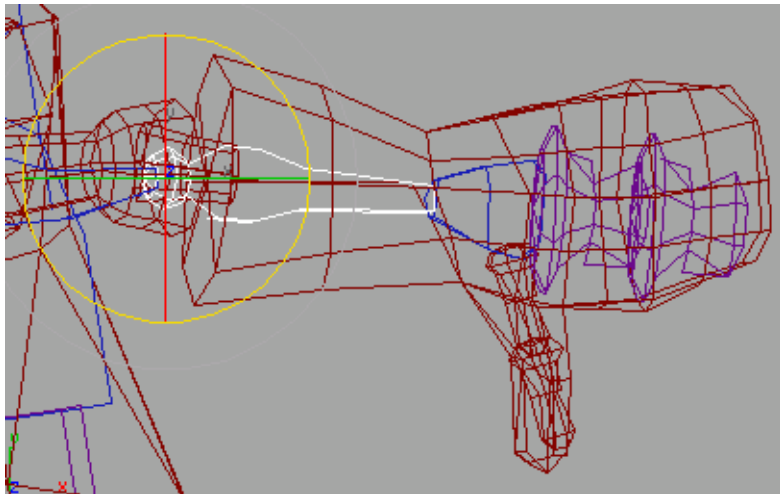

- 2 Select *DrX Biped L Forearm* and rotate it up and down. Some vertices don't move with the arm.



Vertices that are not influenced by the envelope pull out of shape.

- 3 Press Ctrl+Z to put the arm back to its original position so you can adjust the envelope.
- 4 Select the *DoctorX* mesh again and in the modifier stack, click the plus (+) symbol next to Physique and highlight the Envelope sub-object.

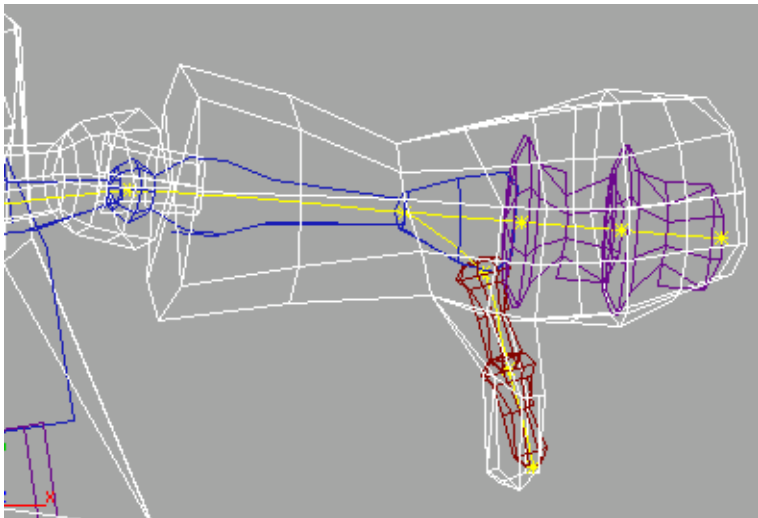

The orange splines running through the biped have turned yellow. These are deformation splines, which deform the mesh as the spline moves.

- 5 Select the deformation spline running along the biped's left forearm to display the associated envelopes.

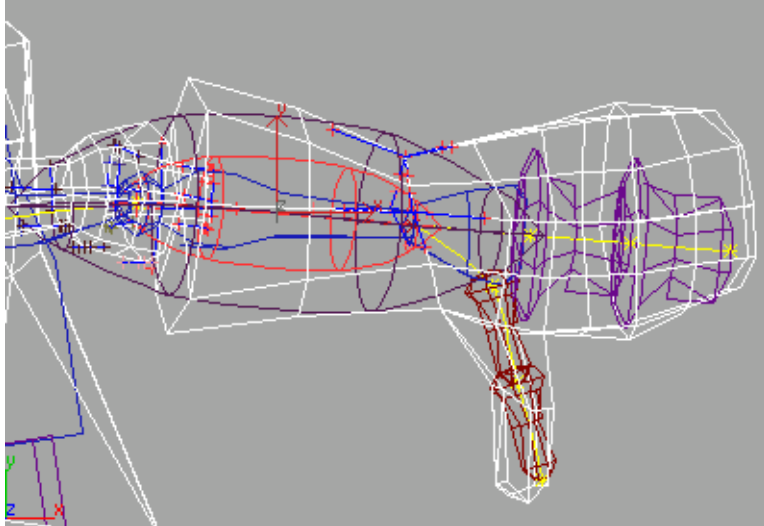

Notice that each biped part has two envelopes, an inner one (red) and an outer one (purple). Some of the vertices near the opening of the glove are outside the outer envelope boundary. These vertices won't be affected at all by the biped's lower arm unless the envelope is enlarged.

- 6 In the Blending Envelopes rollout, in the Envelope Parameters group, increase the Radial Scale parameter to **2.0**.

The vertices at the opening of Dr. X's glove are now within the envelope.

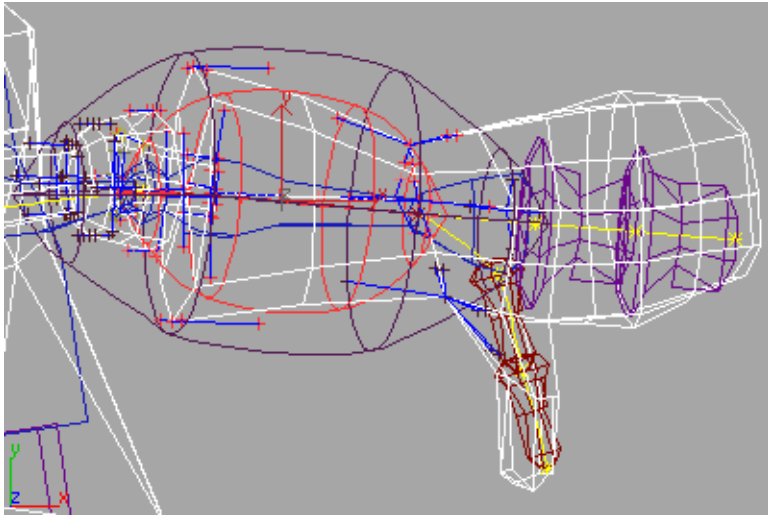

The dark outer envelope completely encompasses the lower arm.

Many more small adjustments are needed to make all the envelopes fit the mesh correctly. In the next lesson, you'll load a file that has a mesh with envelopes that are properly adjusted.

NOTE Keep in mind that the default envelopes are based on the size of the biped bones. Therefore, if you adjust the envelopes of a character that uses the Classic biped body type, and later change to the Skeleton body type, the envelopes are going to be much smaller and will require more editing.

When you have finished adjusting envelopes, you can apply a MeshSmooth modifier to the mesh above the Physique modifier to make the mesh look smoother.

- 7 Apply the MeshSmooth modifier to the mesh above the Physique modifier, and make sure that its Iterations value is set to 1.

When MeshSmooth is placed above Physique on the stack, you only need to adjust envelopes for the low-poly version of the model. The Physique settings are passed up the stack to the MeshSmooth modifier.

- 8 Save your work as **my_drx02.max**.

If you want to learn more about adjusting envelopes and vertex assignments, see the lesson [Adjusting Envelopes](#) on page 927.

Animating the Biped with Freeform Animation

There are two types of animation that a biped can perform: Freeform animation and Footstep animation. In this lesson, you'll use Freeform animation to make Dr. X do a series of deep knee bends. Freeform animation does not use footsteps. You manually set all the keys in a Freeform animation.

To get an idea of how your animation should turn out, view the preview animation, *drxkneebends.avi*, in the folder `\sceneassets\renderassets\`.



Dr. X doing his deep knee bend exercises.

Set up for this lesson:





- 1 Open the scene file *cs4_qs_drx03.max*.
This scene contains Dr. X with properly adjusted envelopes.



- 2 Press the H key and choose *DrX Biped L Foot* from the object list.

Plant the feet:

Since Dr. X is doing squats, his feet are not required to move. You'll plant his feet to keep them from moving throughout the exercise.

- 1  Open the Motion panel.
- 2 Expand the Key Info rollout, and expand the IK expansion bar. The left foot is selected, so you can set a key for it.
- 3  In the Key Info rollout, click Set Planted Key.
- 4  In the Track Selection rollout, click the Opposite button to select DrX Biped R Foot.
- 5  Click Set Planted Key to set a key for the right foot.

Animate the first knee bend:

You'll start by animating the knee-bending motion. Dr. X will start the knee bend in his current stance with arms outstretched, and perform a total of four squats. When completed, he'll return to his original stance.

When the feet are planted, you animate the knees bending by moving the biped's center of mass up and down.

- 1 Make sure the time slider is at frame 0.



- 2 In the Track Selection rollout, click Body Vertical.

This selects the center of mass's body vertical track.



- 3 Turn on Auto Key.

- 4 Move the center of mass (COM) downward slightly to make the character's knees bend a little bit.



This places a key for the center of mass's body vertical track at frame 0.

- 5 Right-click the Front viewport to activate it, and move the time slider to frame 15.



- 6 Move the COM down about -0.25m on the Z-axis.

Watch the Coordinate display Z-field until it reaches about -0.25m and release the mouse button. A key is automatically created at frame 15. This is Dr. X's squatted pose.



- 7 Scrub (drag) the time slider to see Dr. X bend his knees once.

Copy and paste the standing posture:

- 1 Move the time slider to frame 0.
- 2 Expand the Copy/Paste rollout.



The tools on this rollout enable you to quickly copy and paste keys from one frame to other frames. By default, the Posture option is selected. This option pastes keys from individual body parts.



- 3 In the Copy/Paste rollout, click Create Collections. Name the Collection **Dr. X poses**.





- 4 Click the Copy Posture button.
- 5 In the Copied Postures field, rename the posture **Standing**.
- 6 Move the time slider to frame 30.

- 7  Make sure Auto Key is still on.
- 8  On the Copy/Paste rollout, paste options group, click the Paste Vertical button.
- 9  Click Paste Posture.

Dr. X stands up again. When you paste a posture with Auto Key turned on, a key is created at the current frame with the new posture. Here, a new key was created for the COM's Body Vertical track at frame 30.

Copy and paste the squatting posture:

- 1 Go to frame 15.
- 2  On the Copy/Paste rollout, click the Copy Posture button. Rename the posture **Squatting**.
- 3  Go to frame 45, and click Paste Posture.

Paste the remaining postures:

Now that you've stored the two postures, you can easily paste them to other frames.

- 1 Go to frame 60. Choose the *Standing* posture from the Copied Postures list, and click Paste Posture.
- 2 Go to frame 75. Choose the *Squatting* posture from the Copied Postures list, and click Paste Posture.
- 3 On frame 90, paste the *Standing* posture.
- 4 On frame 105, paste the *Squatting* posture.
- 5 On frame 120, paste the *Standing* posture.

You have now created all the knee-bend motions for this animation. If you like, you can play the animation to see the motion.

- 6  Turn off Auto Key.
- 7 Save the scene as **MyDrX02.max**.

Animate the arms:

Now that the legs are set to bend, you'll rotate the arms and lock the upper body. As Dr. X dips down, his arms are going to swing forward, then back out to his sides as he rises. You'll also set two keys to lock the upper body to keep Dr. X facing forward.

- 1 Press the H key and choose *DrX Biped L UpperArm*.

- 2  From the Track Selection rollout, click the Symmetrical button to select the opposite upper arm.

- 3 Move the time slider to frame 0.

- 4  On the Key Info rollout, click Set Key.
This sets a key for the arms in their outstretched position.

WARNING Be sure to use the Set Key button on the Key Info rollout, not the Set Key text button under Auto Key.

- 5  On the Copy/Paste rollout, click Copy Posture. Name the posture **Arms Out**.

- 6 Move the time slider to frame 15.

- 7  Turn on Auto Key.

- 8  In the Top viewport, rotate the arms about -75 degrees around the Z-axis.

Look at the Z-field in the Coordinate display Z-field when rotating the arms. A key is added, and Dr. X's arms are in the forward position.

TIP Sometimes the arms will rotate in parallel, instead of in opposite directions. If this happens to you, select and rotate each arm individually.



- 9 On the Copy/Paste rollout, click Copy Posture, and name the posture **Arms Forward**.
- 10 Paste the copied postures to set keys for the arms on these frames:
 - Frame 30: Arms Out
 - Frame 45: Arms Forward
 - Frame 60: Arms Out
 - Frame 75: Arms Forward
 - Frame 90: Arms Out
 - Frame 105: Arms Forward
 - Frame 120: Arms Out
- 11  Turn off Auto Key.

Play the animation:

- 1 Select all the parts of the biped, and right-click and choose Hide Selection.

- 2 Select the mesh. In the Modify panel, turn on the MeshSmooth modifier by clicking the light bulb to turn it on.
- 3  Play the animation.
- 4 Save the scene as **my_drx03_freeform.max**.

Save a motion clip:

When you're happy with the results of the animation, you want to save it so that in the future you can apply the motion to other bipeds in other scenes. When you save a motion, it is saved in the *.bip* file format, the native format for biped character movement.

- 1 Right-click a viewport and choose Unhide All.
- 2 Select any part of the biped.
- 3  From the Biped rollout, choose Save File.
The Save File dialog displays.
- 4 Specify a folder where you are storing your motion files such as a new *\character_animation\motions* folder.
- 5 Type **my_kneebends** as the file name and click Save.

The motion is saved as a BIP file.

To learn more about freeform animation, see the tutorial [Animating with Freeform](#) on page 761.

Animating the Biped with Footsteps

Now that you're familiar with freeform animation, you'll learn the basics of footstep animation. Footstep animation only controls the placement of the biped's feet. In this lesson, you'll create a footstep animation where Dr. X walks for eight steps.

You can see what your animation should look like by viewing the preview animation, *drxwalk.avi*, in the folder *\sceneassets\renderassets*.



Set up the lesson:

- 1 Reload *cs4_qs_drX03.max* from the *\character_animation\quick_start* folder. This scene contains Dr. X with Physique applied to the mesh, and all envelopes adjusted. The mesh is ready for animation.



- 2 Press the H key and choose *DoctorX* from the object list.

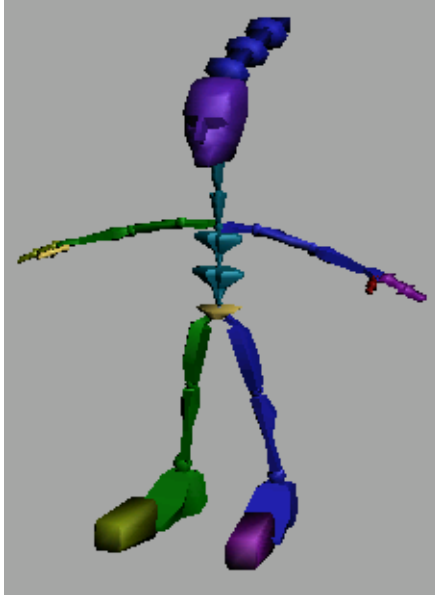

- 3 In the Perspective viewport, right-click the mesh and choose Hide Selection from the quad menu.
Hiding the mesh makes it easier to select the biped and test the animation. This is especially true if you have a highly detailed mesh.





- 4 Press the H key again and choose *DrX Biped*, the center of mass.

Create the footsteps:

Now you'll make Dr. X walk forward in a straight line.

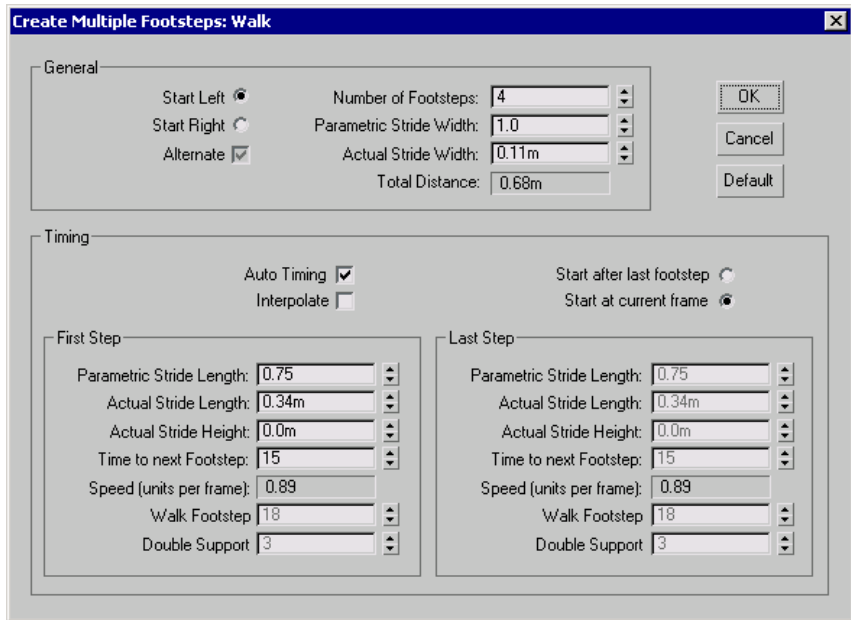
- 1  Open the Motion panel.
- 2  On the Biped rollout, turn on Footstep Mode.
Using the rollouts that now display, you'll create footsteps for Dr. X.
- 3  On the Footstep Creation rollout, click the Create Multiple Footsteps button.
The Create Multiple Footsteps: Walk dialog opens.



- 4 In the General group, increase the Number Of Footsteps to **8**, then click OK.
- 5  In the Footstep Operations rollout, click Create Keys For Inactive Footsteps.

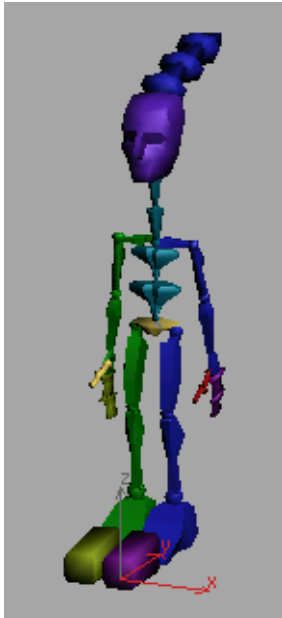

When the footstep keys are created, Dr. X changes his pose.

- 6  Click the Play Animation button. You can also scrub the time slider to examine the animation more closely.

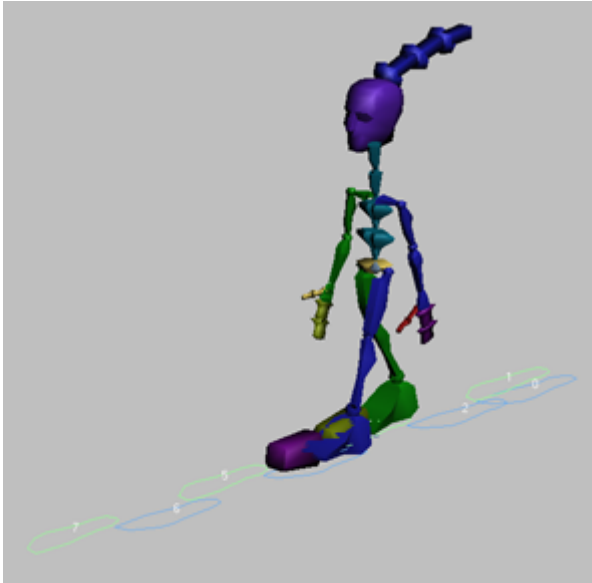

By just watching the biped walk, you can tell that Dr. X's walk doesn't look right. You can see that the feet are too close together, and his arms are straight down at his side. In addition, the shoes and hands will collide or intersect with other body parts when the mesh is displayed again. Next, you'll do some fine tuning to make Dr. X's walk look better.

Fine-tune the animation:

In this part of the lesson, you'll make a few adjustments to clean up the animation.

- 1 If you don't see footsteps outlined in front of Dr. X, do the following:
 - On the Biped rollout, click the gray expansion bar below the buttons. Additional buttons appear.
 -  In the Display group, click the Show Footsteps And Numbers button.



NOTE If the footsteps still fail to display, click the Show Footsteps And Numbers button and hold until you see the button flyout. Choose the Show Footsteps And Numbers button from the flyout.

- 2 In the Perspective viewport, zoom out, if necessary, to see all the footsteps. Drag a selection window around all the footsteps. Be sure to include the two footsteps under the biped's feet.
The footsteps turn white after they're selected.

NOTE Because you're working in Footstep mode, only the footsteps can be selected, so you can drag over the biped without fear of selecting other objects.

- 3 On the Footstep Operations rollout, turn off Length and increase the Scale to **2.5**.



The biped's stance widens to more closely match how it looked in Figure mode. However, now that the stance is wider, the hands will intersect the legs when the mesh is unhidden. You'll fix that next.

Rotate the arms:



With the wider stance, the hands intersect the legs as they swing past. Now you'll do a little freeform animation to give the arms some clearance.

- 1  On the Biped rollout, turn off Footstep mode.
Now you can rotate Dr. X's arms.

2 Press the H key and select *DrX Biped L Upperarm*.

3  In the Track Selection rollout, click the Symmetrical button.

Notice the keys in the time line. At each of the keys, you'll rotate the arms.

4   Turn on Auto Key and Key Mode Toggle, then click the right arrow on the time slider.

The time slider jumps to frame 30.

5  On the main toolbar, click the Rotate button.

6 On the Coordinate display, in the Y field, enter **12**.



The arms are rotated out away from the body.



TIP Sometimes the arms will rotate in parallel, instead of in opposite directions. If this happens to you, select and rotate each arm individually.

7 Continue clicking the right arrow on the time slider to jump to the next key and repeat the same amount of rotation for each key on the time line.

Don't forget the key at frame 0.

- 8  Turn off Auto Key to end the animation process.
- 9  Play the animation.





Save the motion in a BIP file:

You can save the footstep motion for later use in other scenes.

- 1  On the Biped rollout, choose Save File.
The Save File dialog displays.
- 2 Specify a folder where you are storing your motion files, such as a new `\character_animation\motions` folder.
- 3 Type **my_DrXWalk** as the file name, and click Save.
The footstep motion is saved in the BIP file.

Prepare for playing or rendering:

-  1 Press the H key. In the Select From Scene dialog, click Select All button, then click OK.
- 2 Right-click the biped and choose Hide Selection.
The biped is now hidden.
- 3 Right-click again, and choose Unhide By Name from the quad menu.
The Unhide Objects dialog displays.
- 4 Select *DoctorX* from the list and click Unhide.
Dr. X's mesh is unhidden.
- 5 Click the mesh to select it.
- 6 On the Modify panel, make sure the MeshSmooth modifier is turned on (the light bulb icon should be white).
-  7 Click the Perspective viewport and then click the Play Animation button.



- 8 Save the scene as **my_drx03_footsteps.max**.

You can find a finished version of this scene in the file *cs4_qs_drX03_footsteps.max*.

Combining Motions with the Motion Mixer

In this lesson, you'll use the Motion Mixer with the two motion files you've just created. The Motion Mixer lets you create a smooth transition between Dr. X doing his deep knee bends and walking.

Set up for this lesson:



- Open the file *cs4_qs_drX03.max* from the folder *\animation\character_animation\quick_start*. This scene contains Dr. X ready for animation.



Open the Motion Mixer:

The Motion Mixer is like a sound mixer, except here you work with animation files instead of audio files. You'll add motion clips, which are *.bip* files, to the Motion Mixer, and create transitions between the clips to blend them smoothly together.

- 1 Select any part of the biped.

-  Open the Motion panel.
 -  On the Biped rollout, turn off Figure Mode if it is on.
 -  In the Biped Apps rollout, click the Mixer button.
- The Motion Mixer window opens.

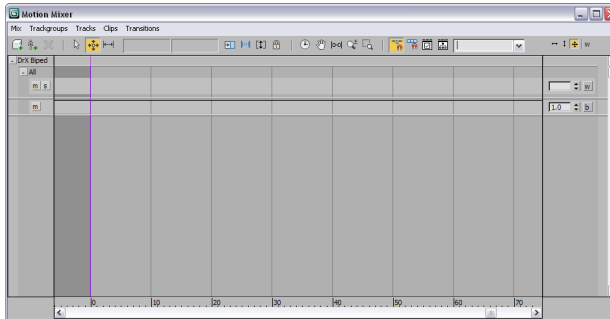

The biped is automatically displayed in the Mixer. It has a default *trackgroup* labelled All, where you will start laying out your tracks, motion clips, and transitions. The label All indicates that motions placed on tracks will apply to the entire biped, rather than specific body parts.

TIP The Motion Mixer window can be resized. For better viewing of what's added to the Mixer, you can drag the edge of the window vertically and horizontally.

-  Opening the Motion Mixer also automatically turns on the Mixer Mode button on the Biped rollout. When Mixer mode is on, the biped performs the motions in the Motion Mixer.

Add the clips to the Mixer:

Trackgroups are populated by *tracks*, in the form of Layer tracks or Transition tracks. On each track, you add *clips* and *transitions*. The final product of your efforts is called a *mix*.

Here, you'll add two clips to the trackgroup with a transition between them.

- 1 Click the topmost track on the All trackgroup to select it. The track turns a lighter gray color when selected.

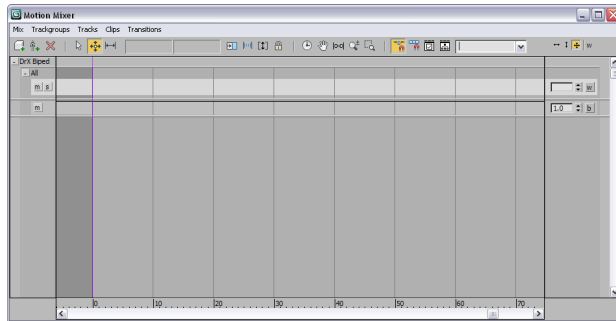

By default, the topmost track is a *layer* track, which is designed for consecutive clips with no transitions between them. You want to create a transition between two clips, so you'll need a *transition* track.

- 2 On the Mixer menu bar, open the Tracks menu and choose Convert To Transition Track.

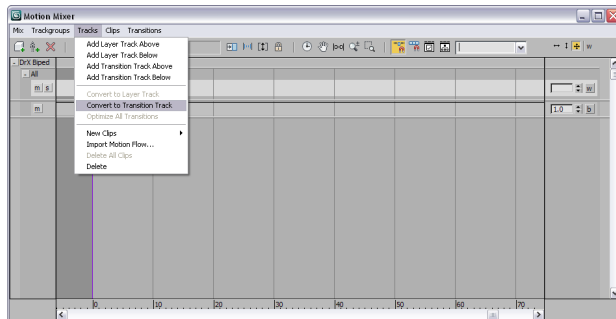

The track is changed to a transition track that is taller than the original, with room for two tracks and a transition.

TIP You can right-click the track to access the same menu options.

- 3 From the Tracks menu, choose New Clips > From Files.

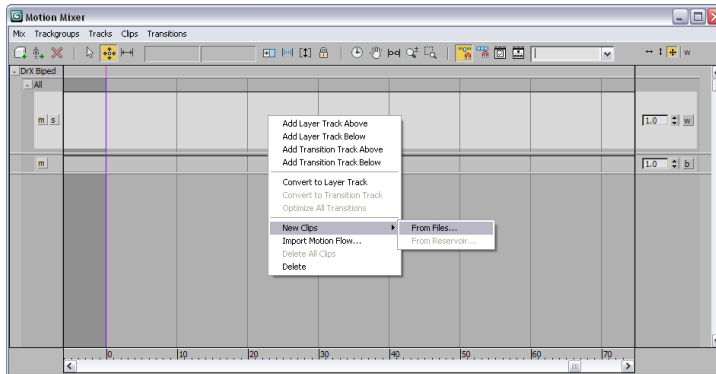

The Open dialog displays.

- 4 If you've done the two previous lessons and want to use the motions you created, browse to the folder where you saved your motions, and choose *my_kneebends.bip*. Otherwise, browse to the folder `\sceneassets\animations\` folder and choose *kneebends.bip*.

The clip holding the knee-bend motion is added to the track.

- 5 Right-click a blank area of the transition track, and choose **New Clips > From Files** from the pop-up menu. Choose the file *my_drxwalk.bip* or *drxwalk.bip*.

The second clip is added to the track, and a transition is automatically added between the two clips. The transition is colored with a darker version of the clip color, and spans the transition time between the two clips.

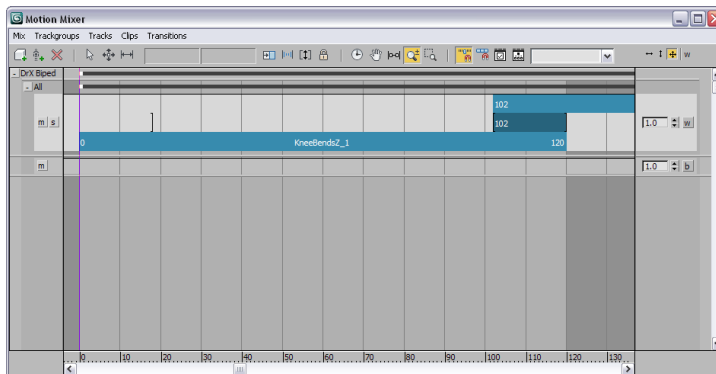

- 6  On the Motion Mixer toolbar, click Zoom Extents so you can see the entire mix in the display.

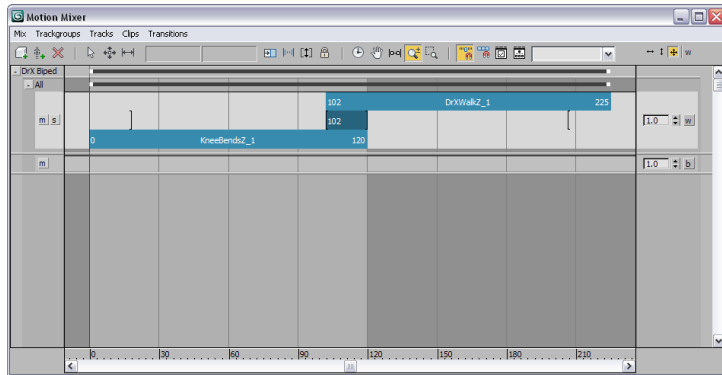

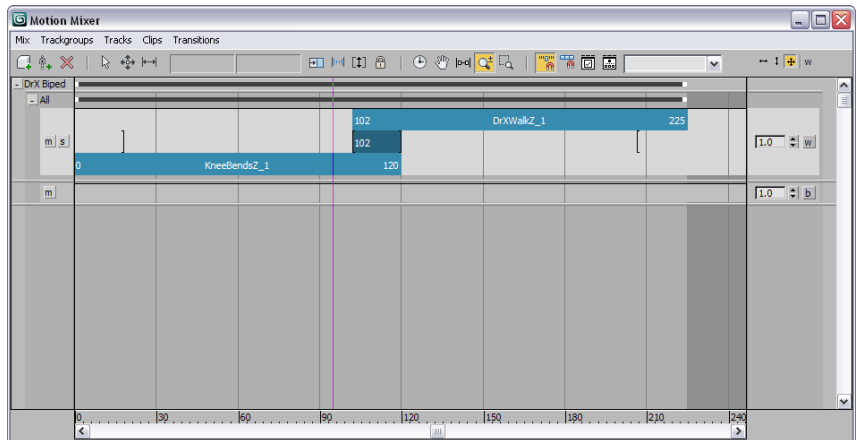

- 7  On the Motion Mixer toolbar, click Set Range.
This feature automatically sets the length of the animation to the number of frames needed for the mix. In this case, it sets the animation length to 225 frames.



Play the mix:

You've just created a basic mix comprised of two clips and a transition. Now you'll play the animation.

- 1  In the Biped rollout, turn on the Mixer Mode button if it's not already active.
- 2  Click the Play Animation button. Watch the animation in the viewport and its progress in the Mixer window.
Dr. X does his knee bends in the first clip.



He smoothly transitions to walking in the second clip.



The feet slide a little during the transition. This problem can be fixed with the Mixer, but that's beyond the scope of this tutorial.

- 3 Save the scene as **my_drx03_mixer.max**.

TIP If you want to render this animation, hide the biped, select the mesh, and turn on the MeshSmooth modifier on the Modify panel before rendering.

Summary

This tutorial introduced you to some of the essential components of **character studio**: creating a Biped system, using the Physique modifier to skin the Biped, animating the Biped in both freeform and footstep modes, and using the Motion Mixer to combine animated clips that have already been created.

Animating with Footsteps

Footstep mode uses a unique footstep gizmo to control the contact of the foot with the ground. When you move a footstep gizmo to a new location, the animation updates to match the move.

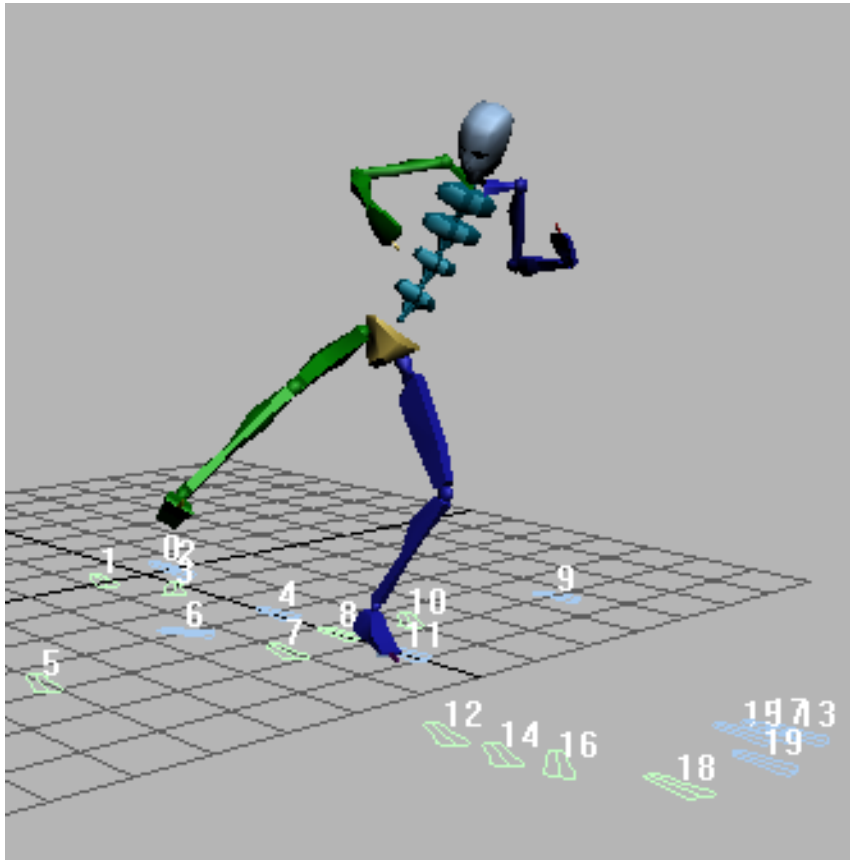

In this tutorial, you will learn how to:

- Animate a biped using footsteps.
- Make a biped walk, run, jump, and follow uneven terrain.
- Change the duration of a footstep animation using IK keys.

Skill level: Beginner

Time to complete: 1+ hours

Creating a Distinctive Walk

In this lesson, using automatically created motion as the basis, you'll animate a biped walking with a rolling, springy step.

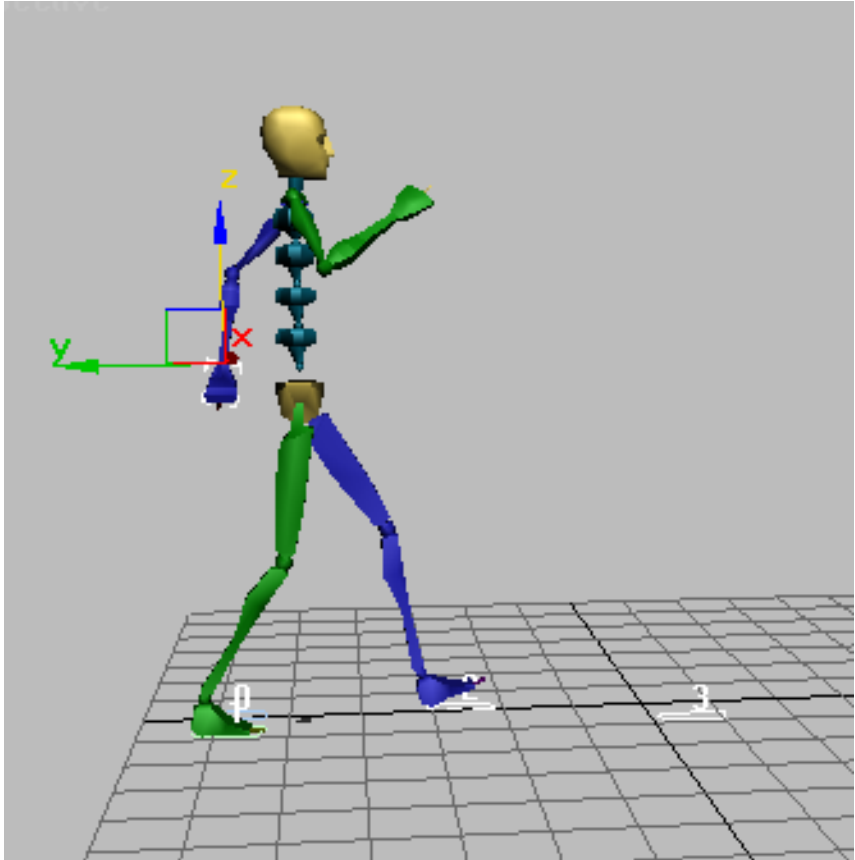

The automatic footsteps generate a starting point for you. You'll then change the automatic walk into something more expressive and distinctive. This sophisticated yet simple approach results in a natural-looking motion that you can create quickly.

Set up the lesson:

- 1 Reset 3ds Max.

- 2  On the Quick Access toolbar, click the Open File button, navigate to the `\animation\character_animation\footstep_animation` folder, and open `walk_start.max`.

In this file, a biped is standing near the origin.

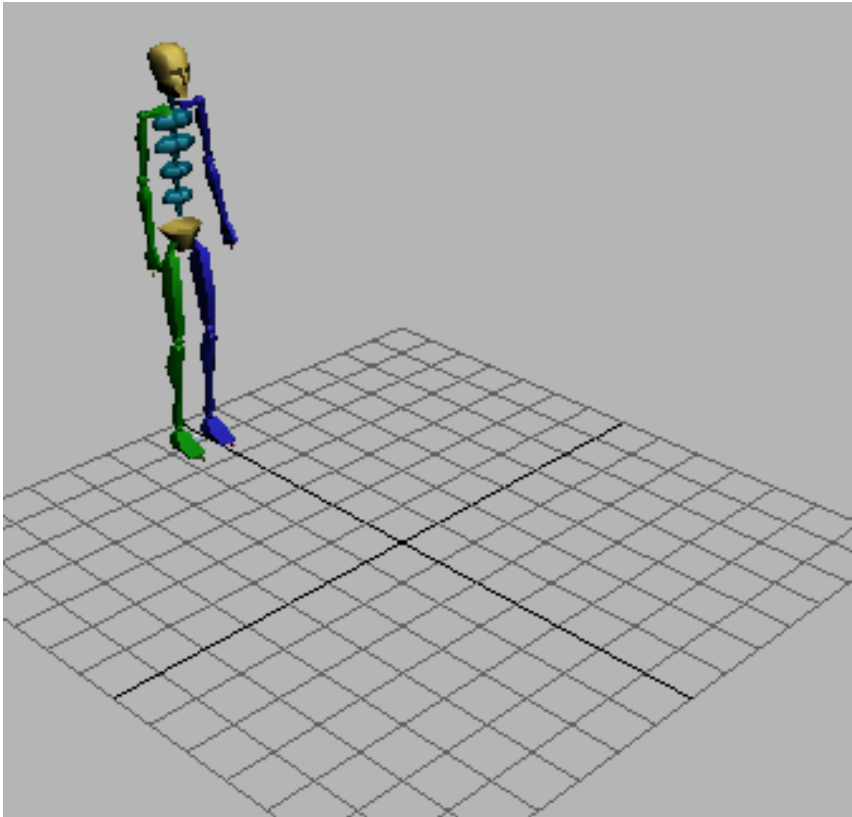

Biped near origin of grid.

- 3 Switch to Local coordinates, if they are not already active.

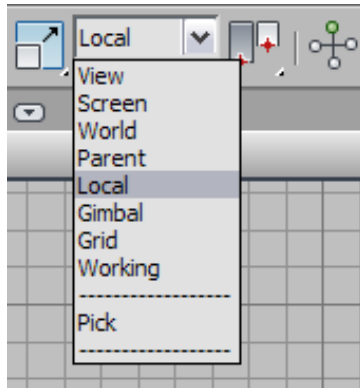

- 4 Maximize the Perspective viewport by pressing Alt+W.
- 5 Click any part of the biped to select it.
A white box outlines the selected body part.



- 6 Open the Motion panel.
The Biped controls are displayed.

Next you'll turn on Footstep Mode. If Figure Mode was on, it turns off automatically.

Create multiple footsteps:



- 1 On the Motion panel, in the Biped rollout, turn on Footstep Mode.



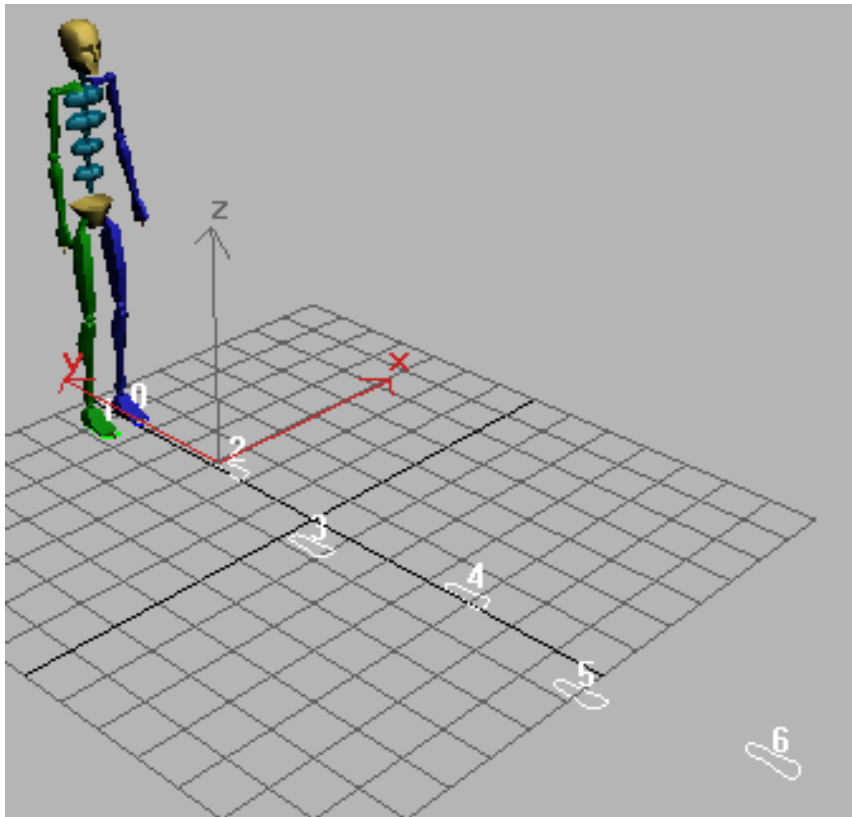

- 2 In the Footstep Creation rollout, click Create Multiple Footsteps.
- 3 On the Create Multiple Footsteps: Walk dialog > General group, change Number Of Footsteps to **8**, then click OK.

Footprints are displayed in white in the viewport. These are inactive footsteps. They do not yet control any animation for the biped. If you click the Play Animation button, the biped won't move.



Inactive footsteps

- 4  In the Footstep Operations rollout, click Create Keys For Inactive Footsteps.
The footsteps are activated. Animation keys are created for the biped.
- 5  Play the animation.
The biped walks.

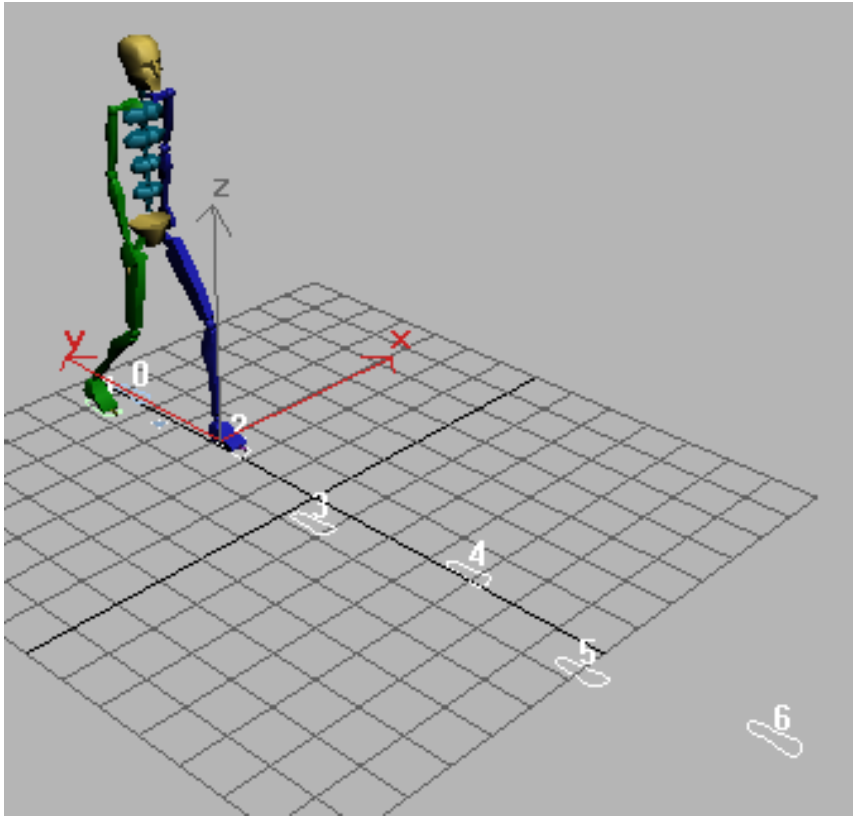

The biped takes a step.

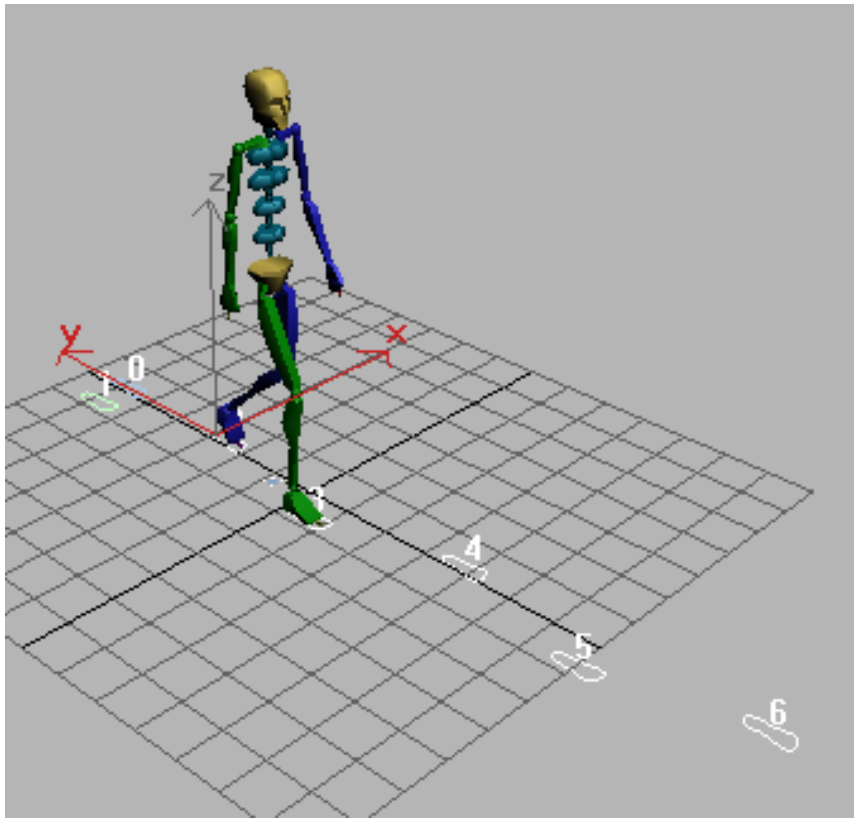

The biped takes another step.

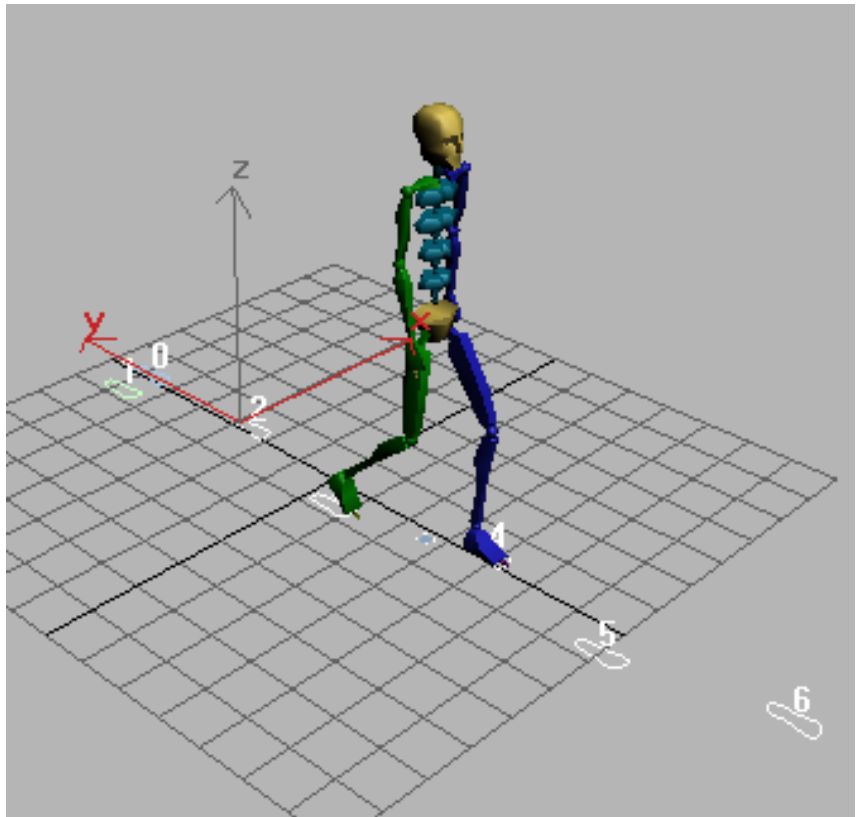

The biped keeps on walking.

- 6 On the Biped rollout, turn off the Footstep Mode button.
Notice that the first footstep is numbered 0, and the last footstep is numbered 7.

- 7  In the Track Selection Rollout, click the Body Horizontal button, if not already selected. This selects the horizontal position track for the center of mass (COM) object.

The track bar displays keys for the length of the animation.



Body Horizontal keys

- 8  Play the animation.

The biped walks, but without much character.

In the following procedures, you'll begin individualizing the motion by adjusting the keys for the Body Horizontal, Vertical, and Rotation tracks. You'll exaggerate the rotation of the center of mass to create a more energetic walk.

Adjust body rotation keys:

- 1  In the Perspective viewport, click the front face of the ViewCube to shift the view so that the biped is walking toward you. Then move the time slider to frame 0.

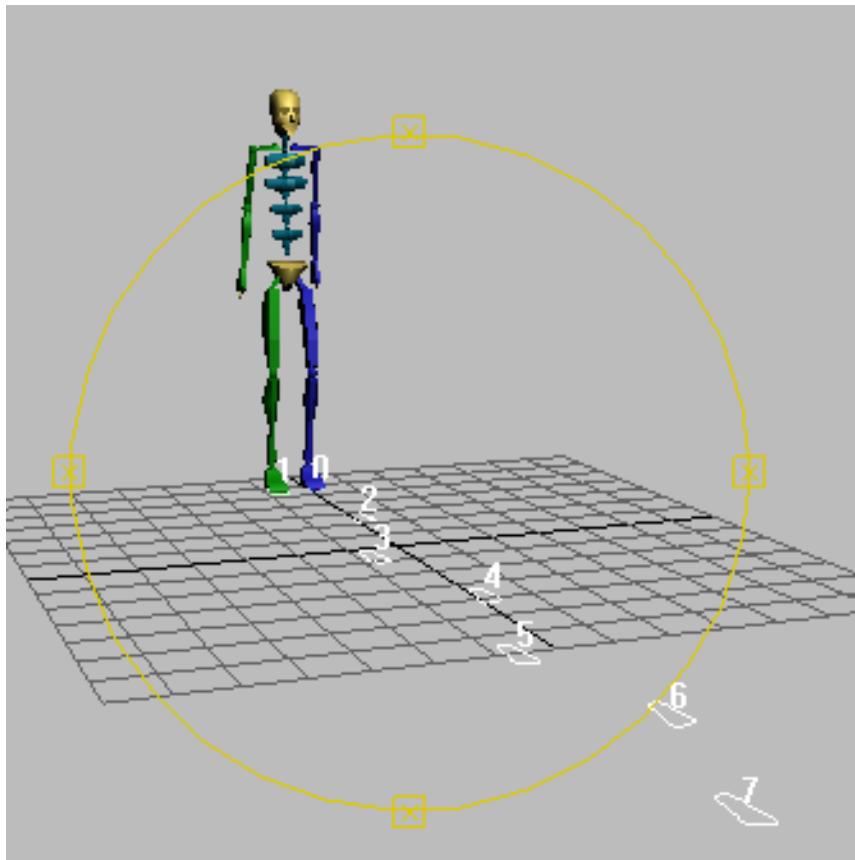



Be sure that a part of the biped is still selected. In the Track Selection rollout, click the Body Rotation button.

- 2 Right-click the track bar, and from the pop-up menu choose Filter > Current Transform.

Now the track bar displays the rotation keys.



- 3 On the 3ds Max status bar, click the Key Mode button to turn on Key mode.

Key mode lets you use Previous and Next Key buttons to jump between keyframes for the selected object. You can also use the < and > keys on the keyboard to move between keyframes without clicking the mouse.

- 4 Press > on the keyboard to move the time slider to frame 24.
- 5 Use the Transform gizmo to adjust the body rotation. Move your cursor over the gizmo; when the circle turns yellow and the X in the center turns red, click and drag to rotate. If you can't see the X, zoom into the viewport. Rotate **5** to **10** degrees about the X axis to move the hips down toward the leg that is in motion. When you rotate, one foot will cross the other.

TIP The rotation is displayed in yellow text above the Transform gizmo, and also in the Coordinate fields on the status bar. You can use the plus (+) and minus (-) keys to change the size of the Transform gizmo.

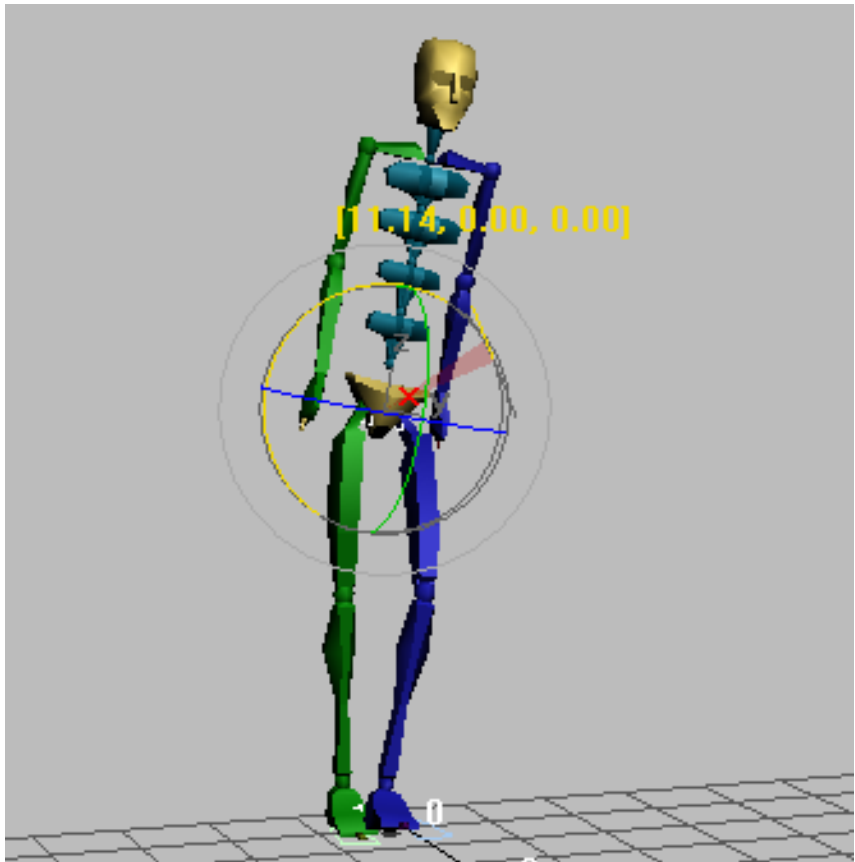

Rotation of the center of mass object about the X axis.

-  On the Motion panel, open the Key Info rollout and click the Set Key button.
When you set the key, the biped will shift position slightly. In the viewport, you can see that the blue foot is no longer crossing the green.

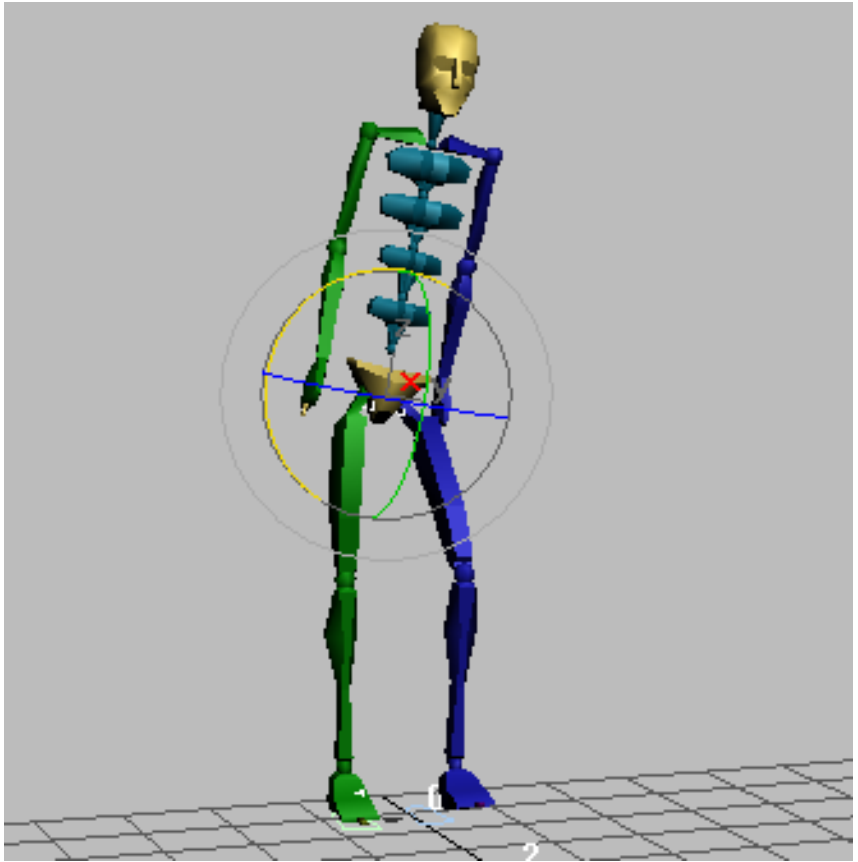

Biped foot snaps away from the other foot.

What is happening is that the foot, calf, and thigh bones are being controlled by the footstep gizmos. The footsteps represent a pair of keys with IK Blend set to 1 and the Join To Prev IK key turned on. When you set the key, these settings force the foot, calf, and leg bones back into the correct path for walking.

- 7  Click Next Key three times to move to frame 40.
- 8 Rotate the Transform gizmo **-6** to **-10** degrees about the X axis.

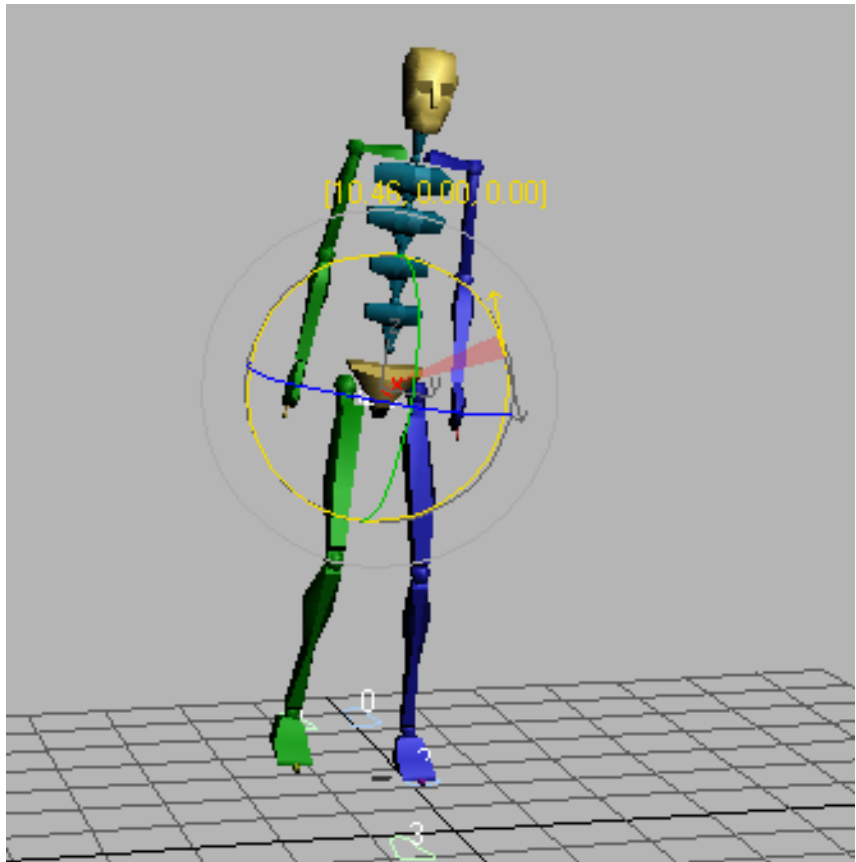

Negative rotation with blue foot in contact with the ground.

- 9 Slowly go through the rest of the rotation keys, repeating this process. At keys where the blue foot comes in contact with the ground (frames 40, 69, and 99), rotate about the X axis in a negative direction, then set a key. At keys where the green foot is down (frames 54, 84, 116), rotate about the X axis in a positive direction, then set a key.

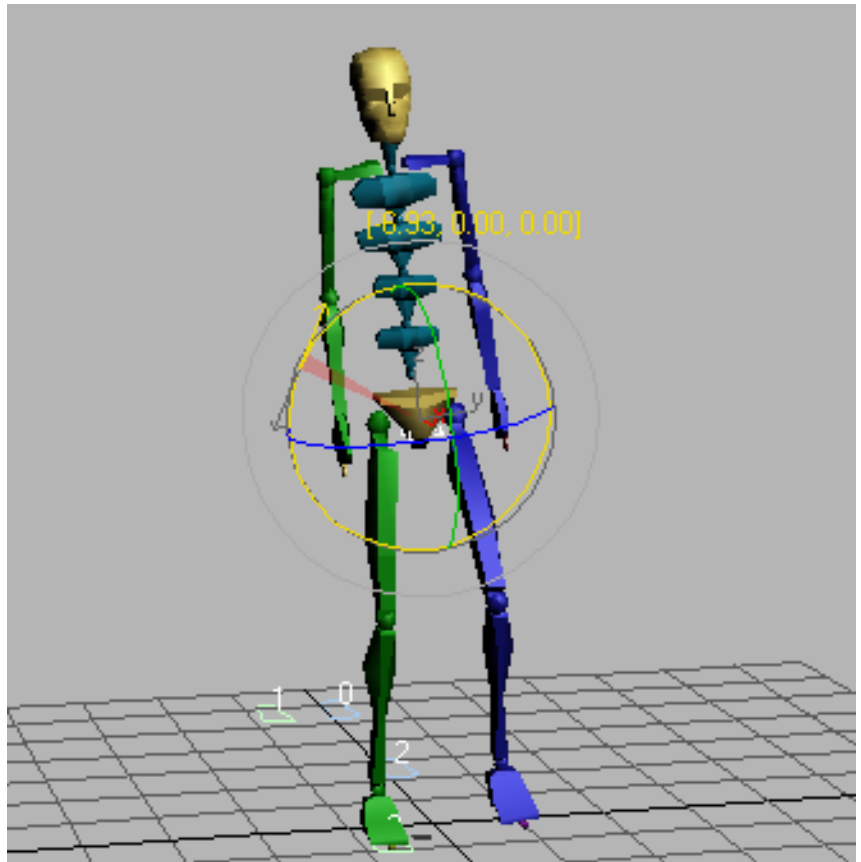

Positive rotation at frame 54.

- 10 Repeat this pattern until you have finished rotating the COM at the end of the animation. Don't make your adjustments too precise. Slight variations from frame to frame make the motion look more natural. When you are done, play the animation and notice the increased hip swings that result from rotating the center of mass back and forth.



- 11 On the Biped rollout, click Save File and save the file as **mywalk.bip**.

If you load the newly saved *mywalk.bip* file into a scene containing a skinned character, the character will swing its hips according to the





instructions you saved in this file. Play the animation to determine if you need to adjust it. For instance, Dr. X (from the quick start tutorial) has huge feet, which may need to be moved further apart so they don't pass through the legs accidentally.



Dr. X character with distinctive walk.

Add spring to the step:

- 1 Continue from before, or load the *mywalk.bip* file that you saved earlier. To load a BIP file, create or select a biped. On the Motion panel > Biped rollout, click Load File and open the file. This transfers all the movement information in the file to the biped.

- 2  On the Track Selection rollout, click the Body Vertical button. This selects the vertical position track for the center of mass object.
- 3  Turn on Key Mode, if it isn't already on.
- 4 Starting at frame 0, move through the animation using the < and > keys. When you come to a frame where either a green or blue foot comes in contact with the ground, move the COM down just a few units. The knees bend because the feet are controlled by the footsteps.
- 5  After making a change at a frame, click the Set Key button on the Key Info rollout. This sets a key for the change you've made in the viewport; otherwise, the change is discarded.
- 6  Play the animation. The biped walks with newfound bounce.
- 7  On the Biped rollout, click Save File. Name the file **mywalk2.bip**.

Add arm and hand motions:

Arm and hand motions are an integral part of an individual's gait. In the following sequence, you'll customize the arm motion by moving the hands and rotating the arms.

You previously created keyframes using the Set Key button; however, for this technique, you'll use Auto Key instead.

- 1 Continue from before, or load *mywalk2.bip*, the file you saved in the previous section. If you prefer, you can begin at the end of the last procedure by opening *springstep.max*.
- 2  Turn on the Auto Key button.
- 3 Move the time slider to frame 0.

- 4 Dragging the time slider to the right, flip through the frames of animation. Drag forward and backward, and watch the how the arms and legs swing. Study the motion carefully.

When the green foot is extended, the blue arm swings forward. When the blue foot swings out, the green arm swings forward. See if you can find the frame at which the hand extends the farthest forward.

- 5 In the viewport, select the green hand of the biped (*Bip01 RHand*). The track bar displays the keys for the hand.

- 6 Move the time slider to frame 30.

There is a key in track bar at that frame for the hand object.

- 7 Right-click the hand, and choose Move from the quad menu.

Using the Transform gizmo, move the hand approximately **10** units upward on the Z axis.

By moving the hand, you've also rotated the two arm bones. The keys for the hand and arm bones are stored on a single track.

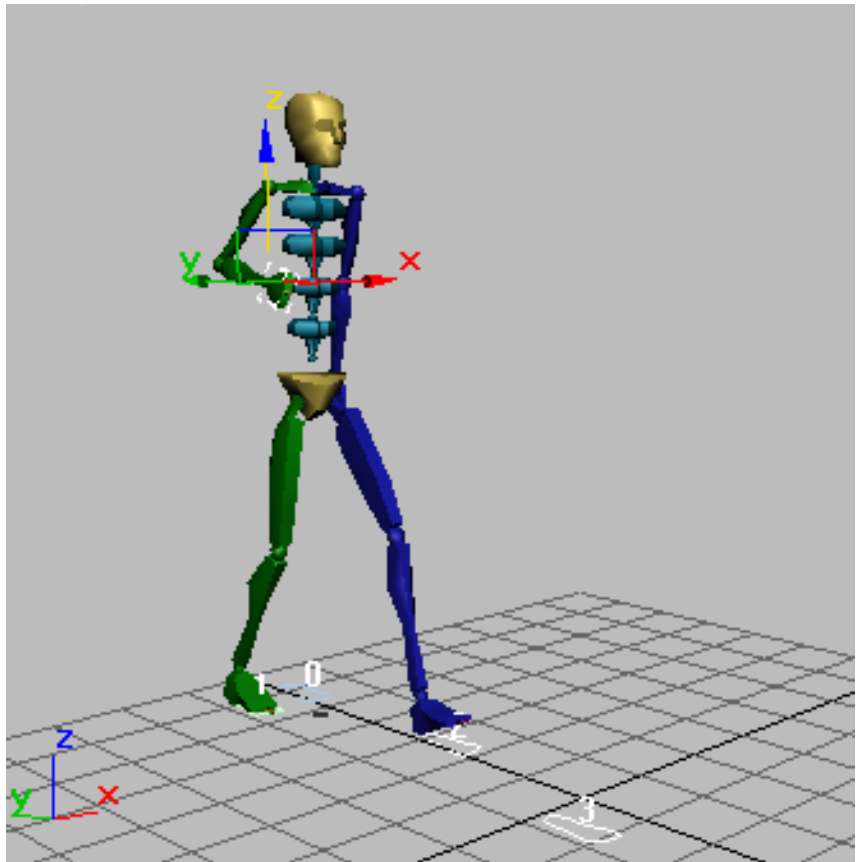

The hand moved upward.

- 8 Select the *Bip01 R UpperArm* object, then right-click and choose Rotate. Rotate the upper arm approximately -30 degrees about the Z axis.

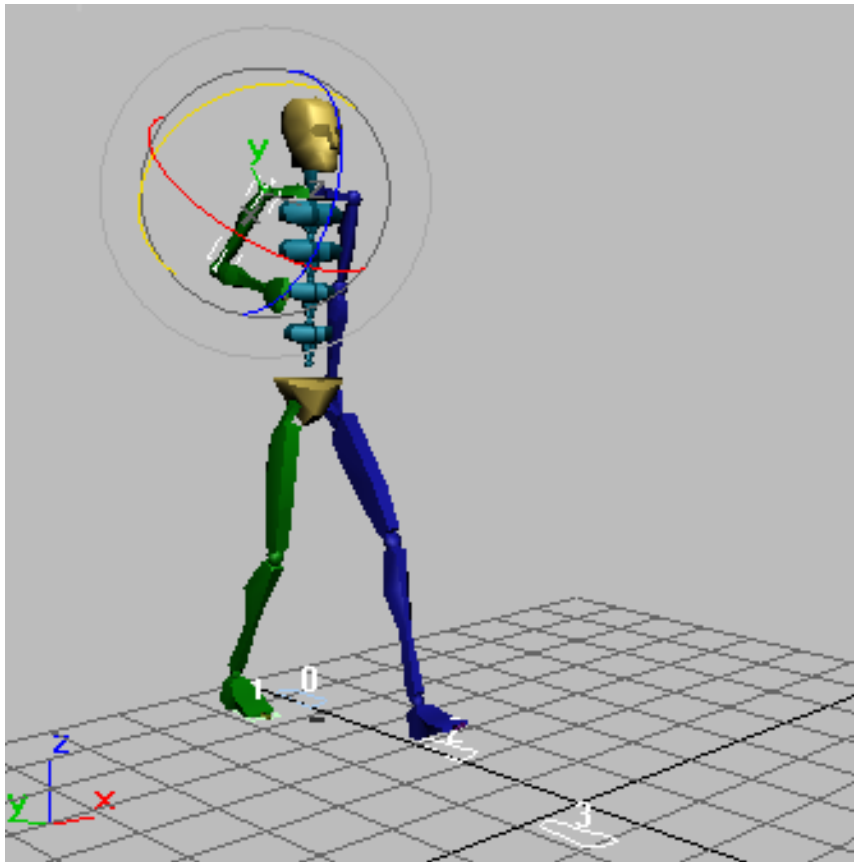

The upper arm rotated around the Z axis.

- 9 Rotate the upper arm approximately **20** degrees about the Y axis, so the elbows are flying out and away from the body.
- 10 Select the forearm object (*Bip01 R Forearm*) and rotate it so the hand moves closer to the chest.

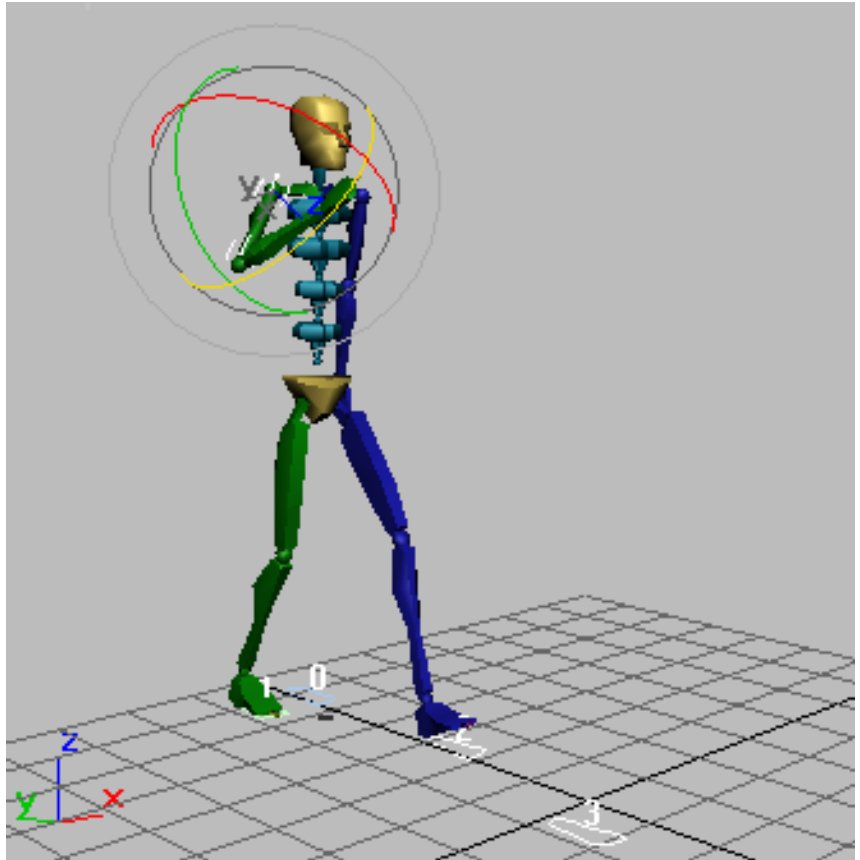

The hand rotated close to the chest.

You can position the arm using forward kinematics (the rotation of the parent objects) or inverse kinematics, using position transform on the end of the chain: in this case, the position of the wrist. You can also rotate the hands.

- 11  Use Orbit to adjust the view angle so you can see the angle of the other arm behind the biped.

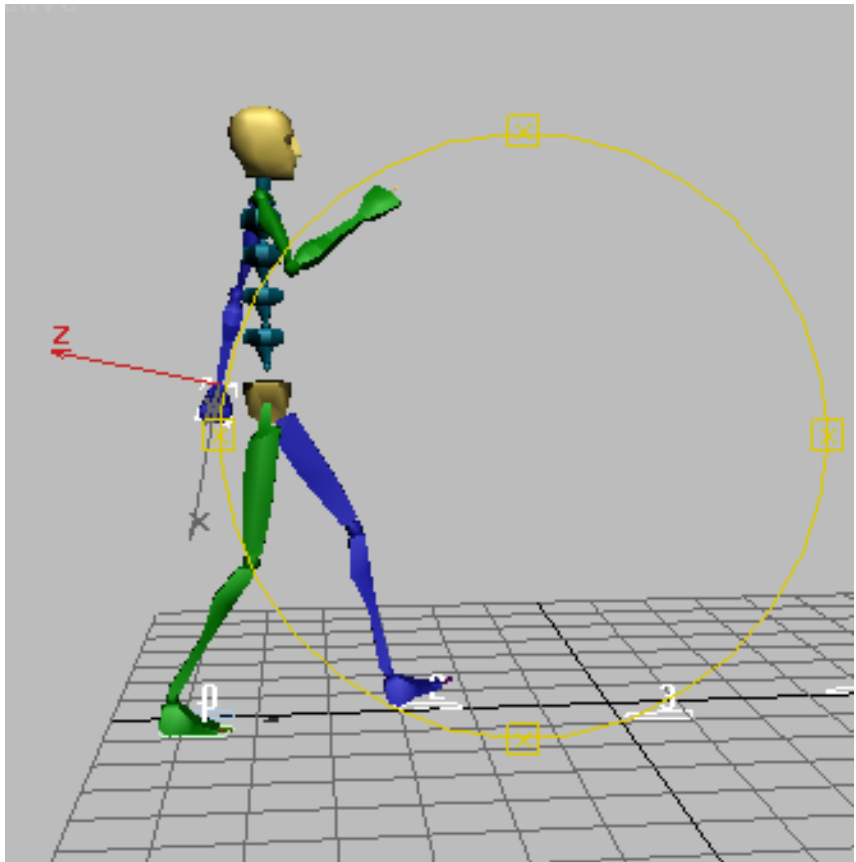

View of the arm behind the biped.

- 12 Select the blue hand, and right-click to choose Move. Move the hand further away from the biped's body. Then move the blue hand upward on the Z axis so the elbow bends slightly.

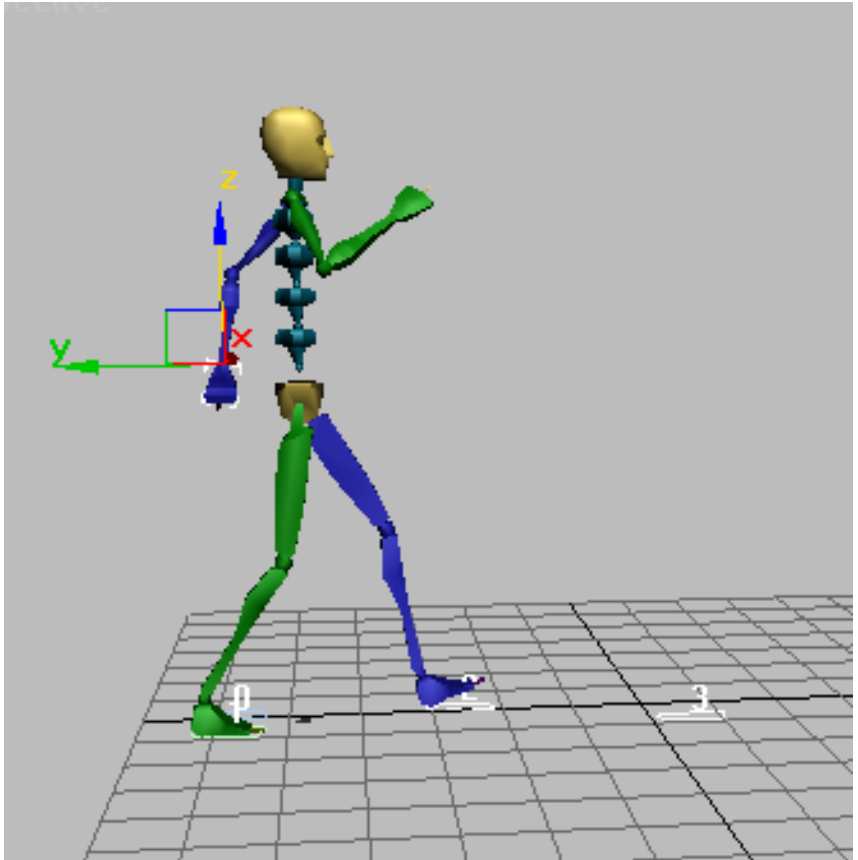

- 13 Move the time slider back and forth to observe the animation so far.
- 14 Repeat the process at frames 60 and 90.
- 15 Repeat for the other side at frames 45 and 75.

TIP If you want exact duplication of these arm positions, you can use the tools in the Copy/Paste rollout. Select both arm assemblies, create a collection, then use Copy Posture and Paste Opposite at the correct frames. See [Creating a Simple Freeform Animation](#) on page 762 for information on using those features.

- 16  Play the animation.

Save it as *mywalk3.bip*.

- 17 To see your work on a skinned character, open *cs4_qs_DrX04.max* from the folder *\animattion\character_animation\quick_start* folder, and then load your *mywalk3.bip* file. For comparison, you can also load *distinctive_walk_final.bip* from the folder *\sceneassets\animations* folder. Remember to select part of the biped to access the Biped rollout.

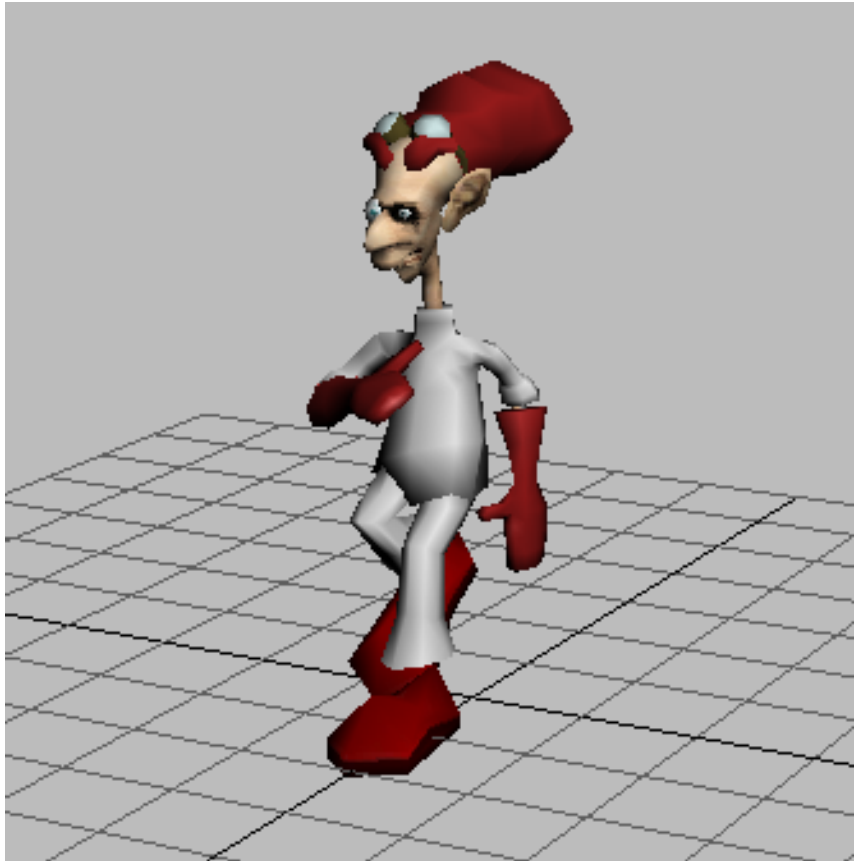

Dr. X with spring in his step.

Add head motions:

You can edit the head motion to make the biped's walk look more natural. In this procedure, you'll add head rotations to accentuate the COM rotation.

- 1  Turn on Auto Key, if it isn't on already.

- 2  Turn on Key mode, if it isn't on already.

- 3 Move the time slider to frame 0.

- 4  In the Perspective viewport, select the biped's head using Rotate on the 3ds Max main toolbar.

- 5 Rotate the head down as if the biped is asleep.

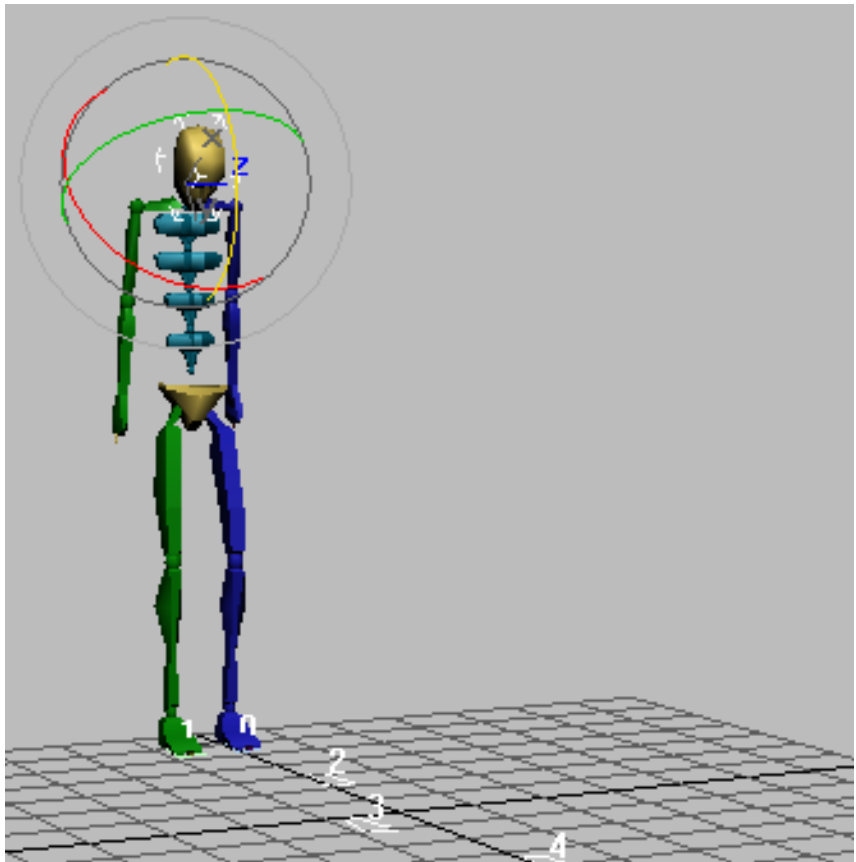

The head rotated downward.

- 6 Move the time slider to the next keyframe by pressing the > key.
- 7 Keyframe rotations for the head. You can rotate the head to counterbalance the angle of the shoulders. Or, you can rotate the head in the opposite direction so it follows the rotation of the COM. Each rotation will give a different result. Extreme rotations should be avoided. Also, be careful to put the rotations only on existing keys.

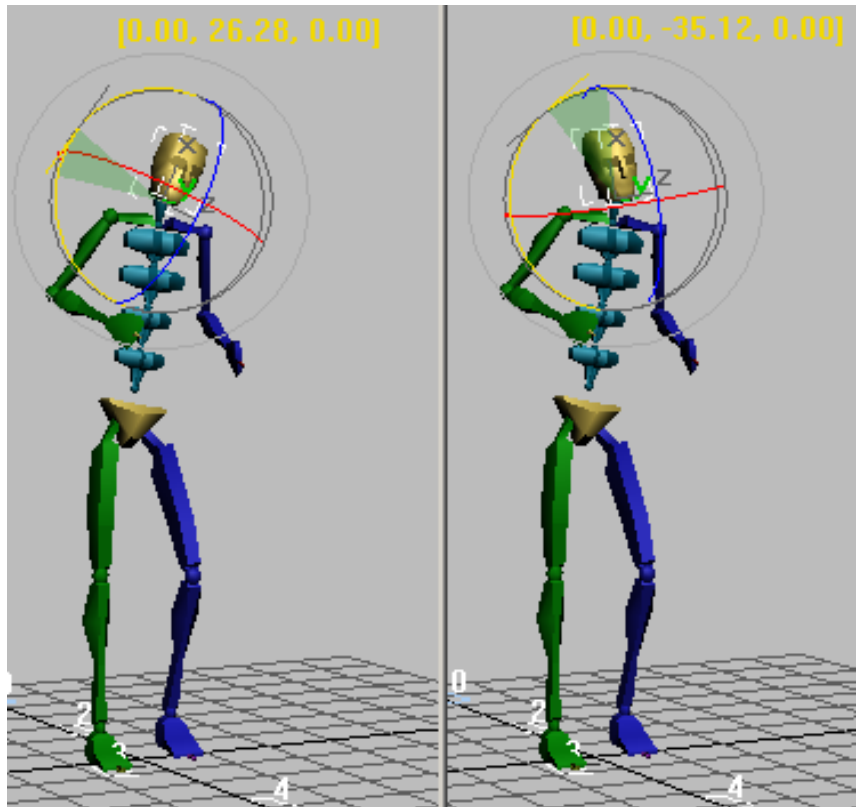

Rotate the head to follow the movement, or rotate the head to oppose the shoulders.

- 8 Continue to jump through the head's keys, setting rotations of your choice to animate the head.
Natural head motion is smooth, so the orientations should change gradually from one key to the next.
- 9 Turn off Auto Key and Key Mode.
- 10 Play the animation, and notice how much the biped's head movements add to the animation.
You can now save your work as **mywalk4.bip**. You can check your file against *head_rotate_with.bip* and *head_rotate_against.bip*. Both these BIP files are in the folder `\sceneassets\animations\`.



Dr. X's distinctive walk with head rotation.

Modifying Footsteps

In this lesson, you'll learn how to copy and paste biped footsteps to extend an animation. You'll also learn how to adjust and bend the steps, and to produce the effect of walking on uneven terrain. You'll also make the biped take a jump.

Set up for this lesson:

- Continue from the previous exercise, or open *paste_footsteps_start.max*. This scene is in the folder `\animation\character_animation\footstep_animation\`.

Extend the walk:

- 1 Select any part of the biped.



- 2 On the Motion panel, in the Biped rollout, turn on Footstep Mode.

The Footsteps sub-object level is activated, and only the footsteps can be selected.

- 3 Activate the Top viewport, then press Alt+W to maximize it.



- 4 Using Select And Move, region-select footsteps 3 through 7.



- 5 On the Footstep Operations rollout, click Copy Footsteps to place the selected footsteps into the footstep buffer.



- 6 Click Paste Footsteps to paste the selected footsteps into the viewport.

The new footsteps appear next to the biped's current footsteps.

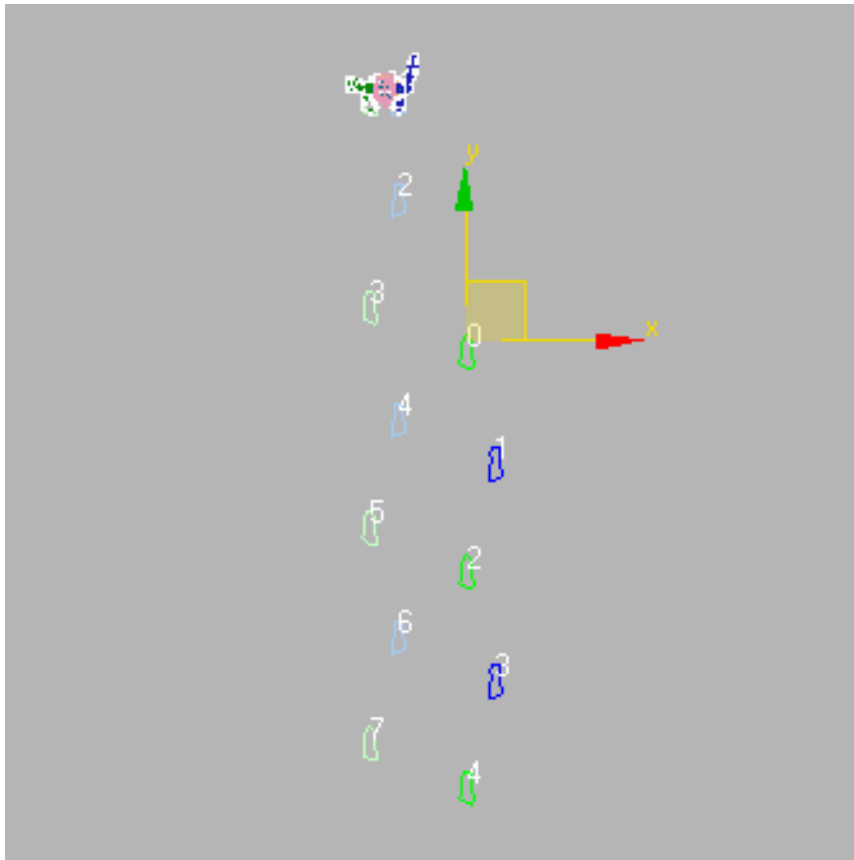

Pasted footsteps appear.

TIP If you have Transform gizmo on, use the minus key (-) to shrink the Transform gizmo, so it doesn't cover up the footsteps.

- 7 The new footsteps can be moved as a set. Move them so the first footstep of the new set is over footstep 7 of the original set. When footstep 7 of the original set turns red, release the mouse button.

Footsteps from the original motion are inserted. Now there are 11 footsteps visible.

- 8 Press Alt+W to display four viewports.

- 9 To display the entire animation in the Perspective viewport, zoom out and adjust your view until the biped and all 11 steps are visible.

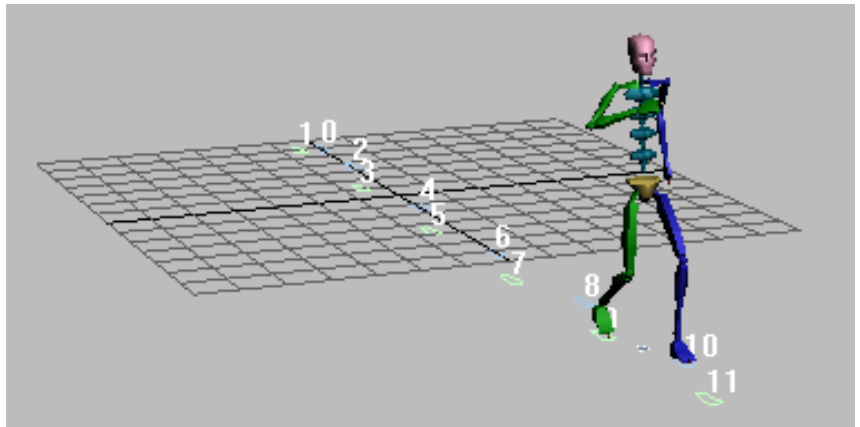

Pasted footsteps extend the motion.

- 10 With the Perspective viewport active, play the animation. Since you are still in Footstep mode, the Motion panel is available. This is a good time to save your *mywalk_pasted.bip* file, using Save File on the Biped rollout.

Scale the walk:



- 1 Make sure that Footstep mode is active.
- 2 In the Top viewport, region-select all the footsteps.
- 3 On the Footstep Operations rollout, turn off Length, and leave Width selected.
- 4 Set Scale to **2.0** to double the spacing between the left and right footsteps.
- 5  Play the animation.
The biped walks with legs apart.
- 6 Set Scale to **0.25** or smaller to reduce the spacing between the left and right footsteps to half of the original scaling (one-quarter the current setting).

If you hadn't previously doubled this parameter, a setting of 0.5 would have scaled the width by 50%.

Now the biped puts one foot in front of the next.

TIP If your character has big feet, or if it's walking on a wire or a ledge, use Scale Width and Length to adjust the footsteps.

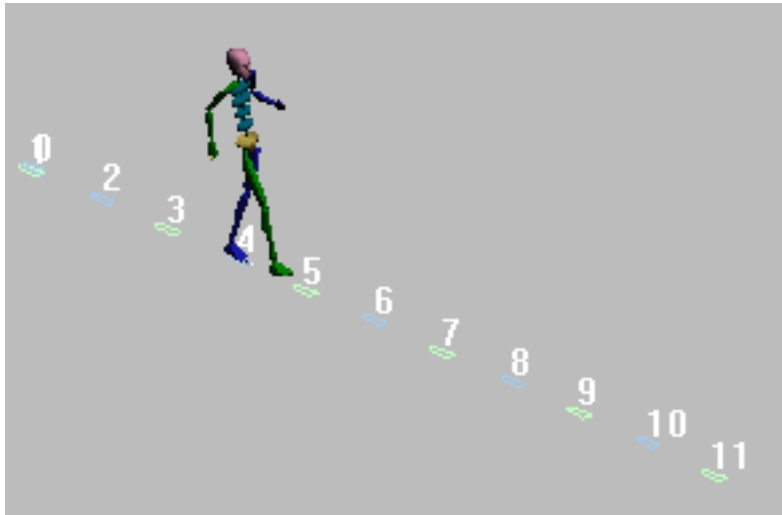

Scale the width between the steps.

- 7  Play the animation.
The biped walks as if on a tightrope.

Bend the walk:

- 1 In the Top viewport, select all the footsteps from 7 on.
- 2 On the Footstep Operations rollout, set Bend to **20.0**.
The footsteps bend to the left, beginning at footstep 7.
- 3 Play the animation.



Walk on uneven terrain:

You can raise and rotate the footsteps to create the illusion of walking on uneven terrain.

- 1 Make sure that Footstep mode is still on.
- 2 Maximize the Perspective viewport.



- 3 Use Select And Rotate to select all the footsteps from 4 on.
- 4 Use the Transform gizmo arrows to rotate the selected footsteps approximately **-15** degrees about the X-axis so the footsteps go up a hill.
- 5 Select footsteps 8 through 11.
- 6 Rotate the selected footsteps about the X-axis approximately **21** degrees, so that the footsteps go back down the hill.
- 7 Select footstep 11. Rotate it so it's parallel with the grid.
- 8 Play the animation.
The biped's feet follow the footstep placement.

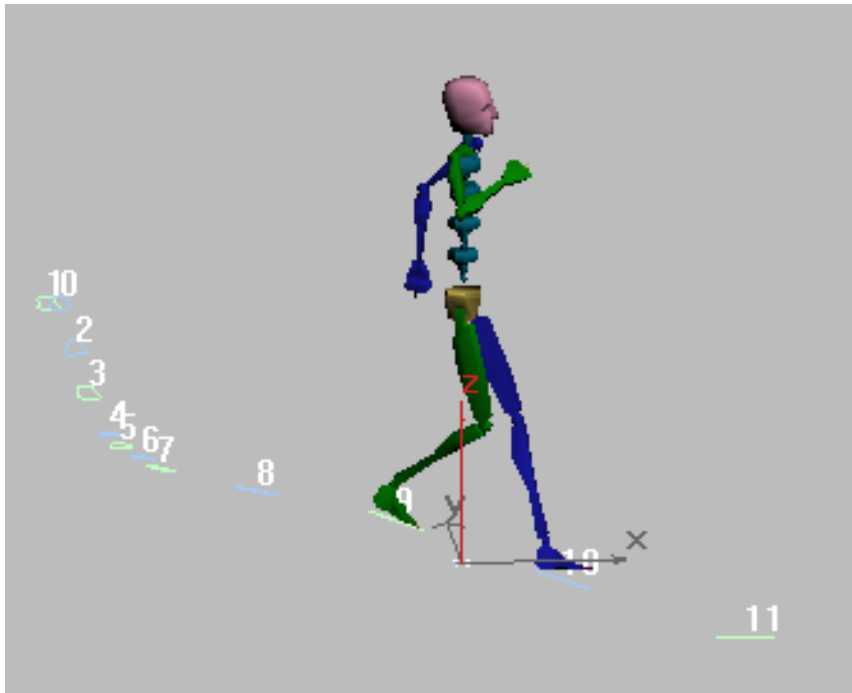

Add a jump:

If there is a period of time during a footstep animation when neither foot is on the ground, the software interprets this period as a jump. There are several different ways to create a jumping animation. In this set of procedures, you'll move footstep keys in Track View to make the jump.

- Open *footsteps_jump_start.max*.
This is a slightly longer version of the same file you've been working on. It has 15 footsteps instead of 11.

Move footstep keys in Track View:

- 1 Select *Bip01*. On the Motion panel, in the Biped rollout, turn on Footstep Mode, if it isn't already on.
- 2 In the viewport, right-click and choose Curve Editor from the quad menu. Track View is displayed.

- On the Track View menu bar, choose Modes > Dope Sheet. Pan the controller window until you can see the *Bip01 Footstep* track displayed in Track View. Expand the *Bip01 Footstep* track

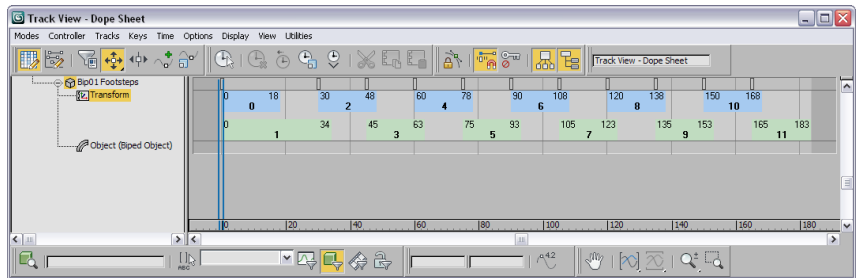

Dope Sheet shows special footstep keys.

In the Dope Sheet display of footsteps, each blue block represents a left footstep, and each green block represents a right footstep. The length of the blocks is the period of time that the foot is in contact with the ground during the footstep. The spaces between the blue and green blocks represent periods in which the biped is not supported by the left or right foot.

- Resize the Track View window, or zoom into the track so you can see the start and end frame numbers on each footstep.
- Select footsteps 11 through 15 by drawing a box around them in Track View, or by dragging a selection region in the viewport.
In Track View, notice that footstep number 11 starts at frame 165.



- On the Track View toolbar, click the Slide Keys button.
- In Track View, click in the center of footstep 11 and drag it to the right until the number 166 (indicating the first frame of footstep 11) increments to number 180. Release the mouse button.

This creates a gap between step 10 and 11. The keys in the other biped tracks adjust to the change in the footstep track.

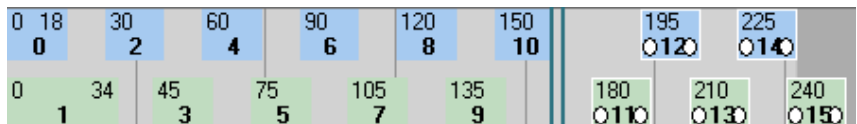

The keys shifted to the right to create a gap.

By creating an area in the footstep track where neither foot is supporting the biped, you have changed a walking step into a jumping step

- 8 Minimize Track View and then play the animation.

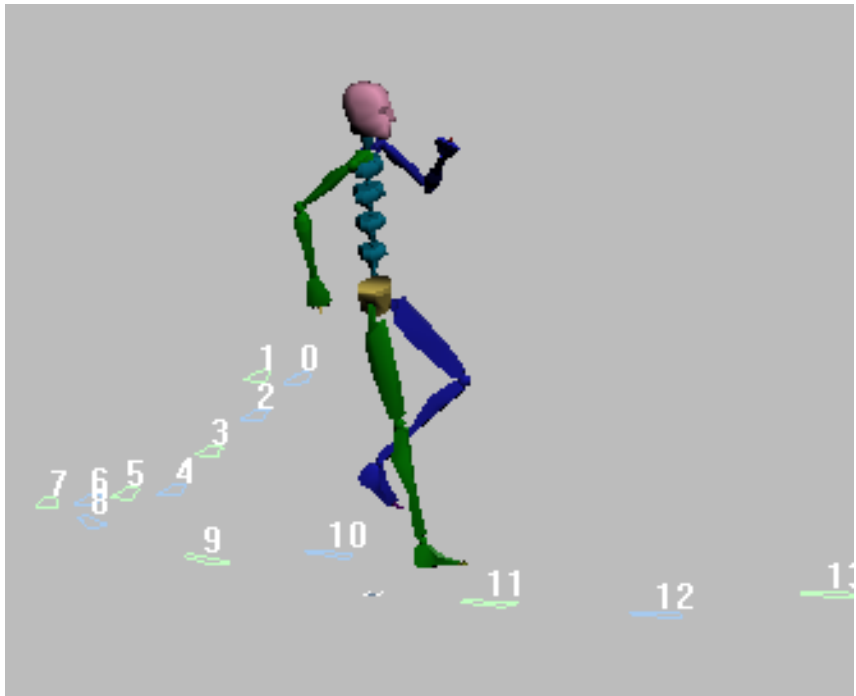

The gap between footsteps creates a jump.

- 9 In the viewport, move footstep 10 so it is next to footstep 9.
- 10 In the viewport, move footsteps 11 through 15 so there is more of a gap for the jump. Move these footsteps about 5–7 units in the X-axis direction.

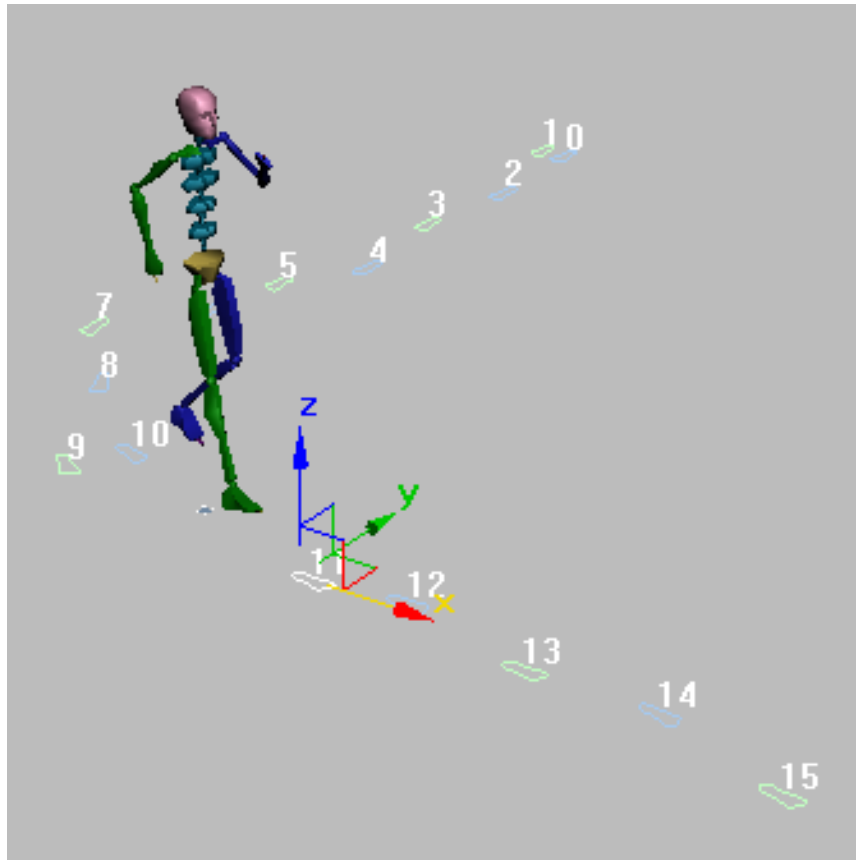

More gap for the jump.

Now, if you shorten the duration of footstep 10, you can accentuate the jump.



- 11 On the Track View toolbar, click Move Key.
- 12 In Track View - Dope Sheet, click the right edge of footstep 10.
A white dot appears only on the right side of the key to show it's selected.
- 13 Drag the right edge of footstep 10 to the left to shorten the duration of the key. Change the key so it ends at frame **160**.



Shorten the duration of footstep 10.

- 14 Play the animation and observe the jump.
- 15 Turn off Footstep Mode.

Make the biped crouch before the jump:

The preparation for the jump, between footsteps 9 and 10, looks a little stiff because the biped is not crouching enough before jumping. Resetting a vertical key will fix this problem.



- 1 On the Motion panel, in the Track Selection rollout, click Body Vertical.
- 2 Move the time slider to frame 153, where there is a Body Vertical track key.
- 3 Press H and select *Bip01*, the center of mass.



- 4 Move the center of mass down approximately **-5** units. Then on the Key Info rollout, click Set Key.

If the biped jumps back to its original position, click Set Key and try again. Click Set Key when you have a crouching position as illustrated here.

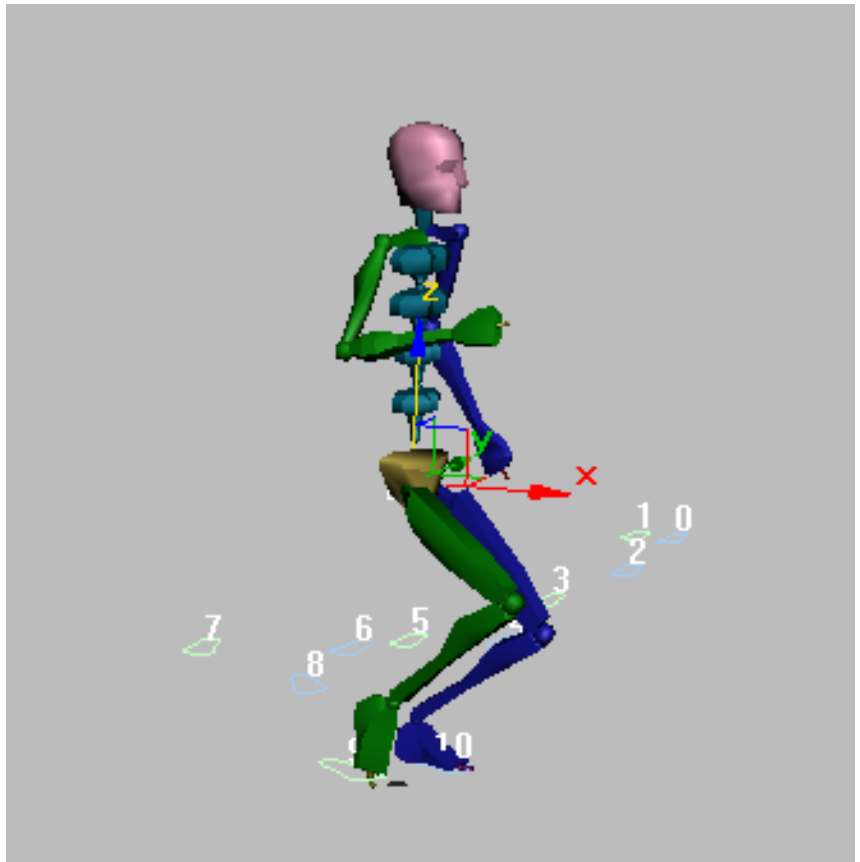

Lower the center-of-mass object using the Body Vertical track.

- 5 Move the time slider to view the animation.
There appears to be a glitch in the motion. There are two Body Vertical keys next to each other that are causing this problem.
- 6 Move the time slider to frame 153.
- 7  In the Key Info rollout, click the Next Key arrow to move to the next key at frame 154. Then click Delete Key to remove this second key.
- 8 Select *Bip01 R Foot*.

9 Move the time slider to frame 167. Click Body Vertical and raise the foot slightly, so the biped's knee is bent.



10 On the Key Info rollout, click Set Free Key to hold the bent knee position. Set additional keys on the foot if it hyperextends before it hits the ground, or if it goes through the ground at takeoff.

11 Play back the animation and observe the motion.

12 In the Track Selection rollout, click Body Rotation. Move the time slider to frame 160. Using the Transform gizmo, rotate the center of mass so the body pitches forward.

The jump looks more natural now. The result should be similar to the jump in *footstep_jump_final.bip*, which is in the folder `\sceneassets\animations\`.

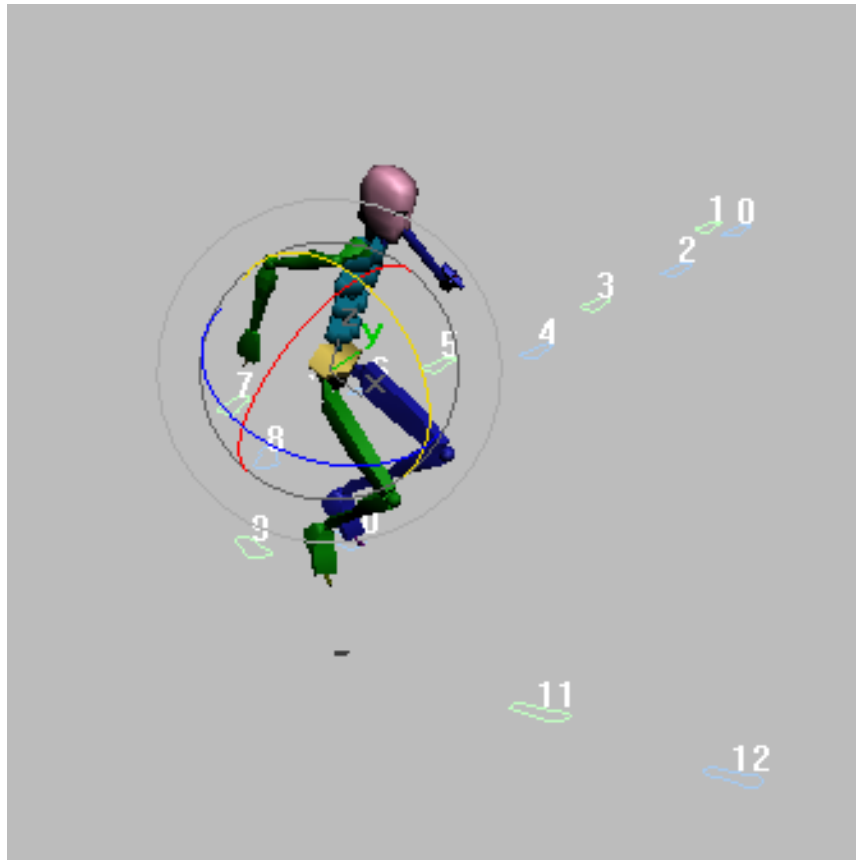

Making a Biped Stop and Start Walking

In just a few key strokes, you can generate multiple footsteps to make a biped walk. But what if you want the biped to stop and pause? To do that, you'll use a simple manipulation of the footstep keys in the Track View - Dope Sheet. Just stretching the length of the selected footsteps changes the animation so the biped pauses in its path.

Make the biped stop and start:

- 1 Open *standstill_start.max*.

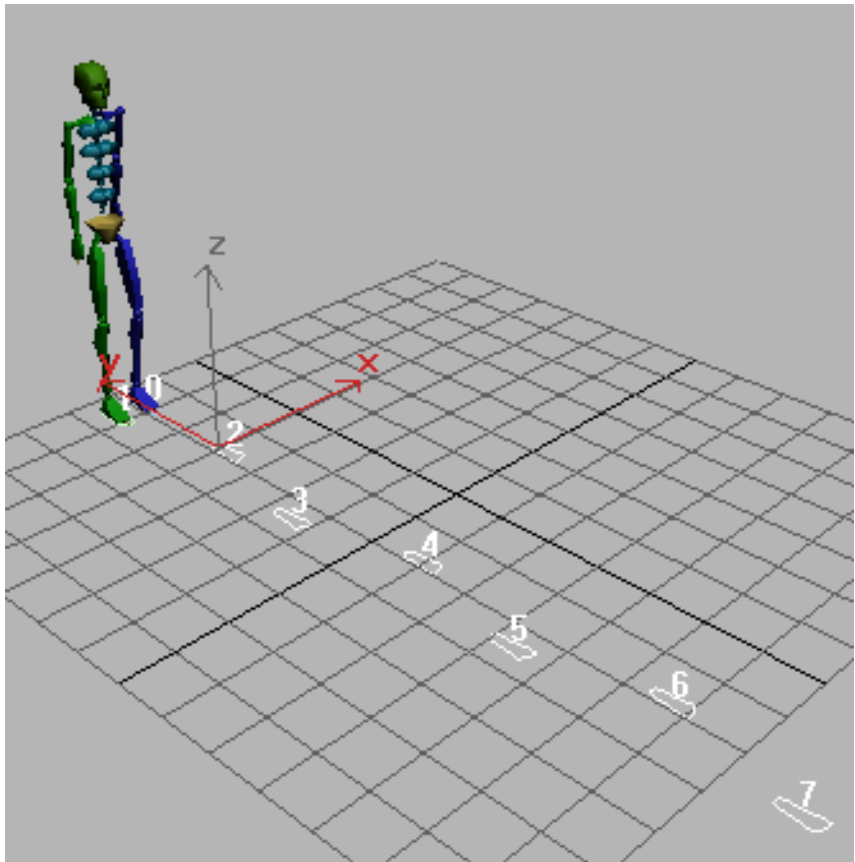

- 2 In the viewport, select any part of the biped.
- 3 Open the Motion panel.
The Biped controls are displayed in the rollouts.

- 4  Play the animation of the biped.
The biped walks seven steps forward without stopping.

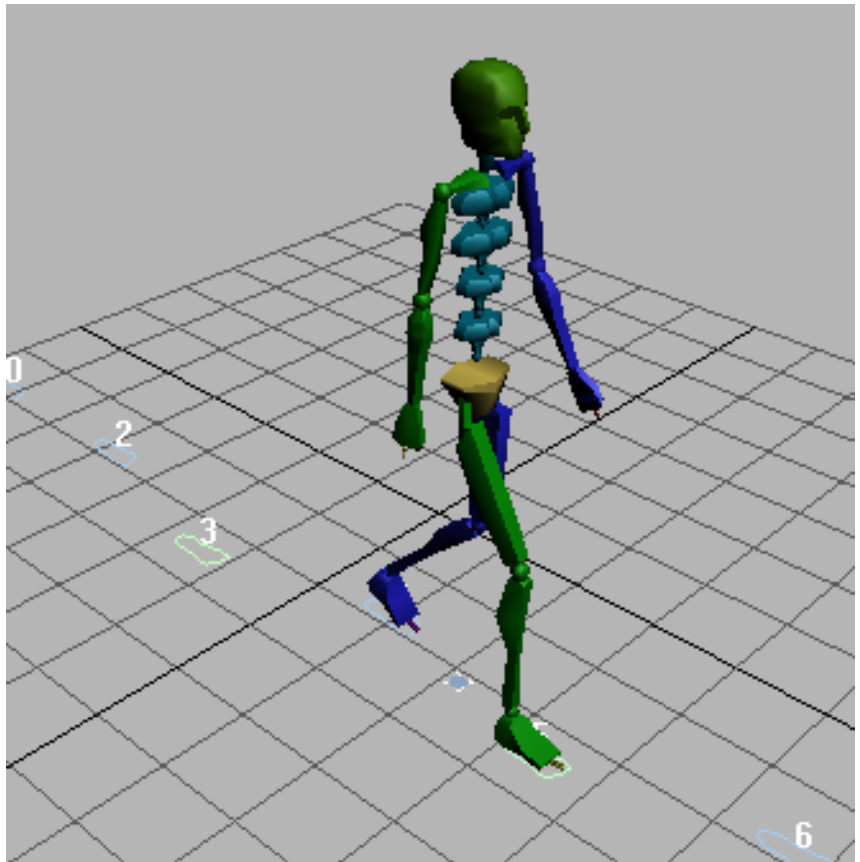

You'll use footsteps 4 and 5 as the footsteps where the biped pauses.

- 5  In the Biped rollout, turn on Footstep Mode.
- 6 In the Perspective viewport, select footsteps 5–7, then right-click and choose Move.
- 7 Move the footsteps so that footstep 5 is next to footstep 4.

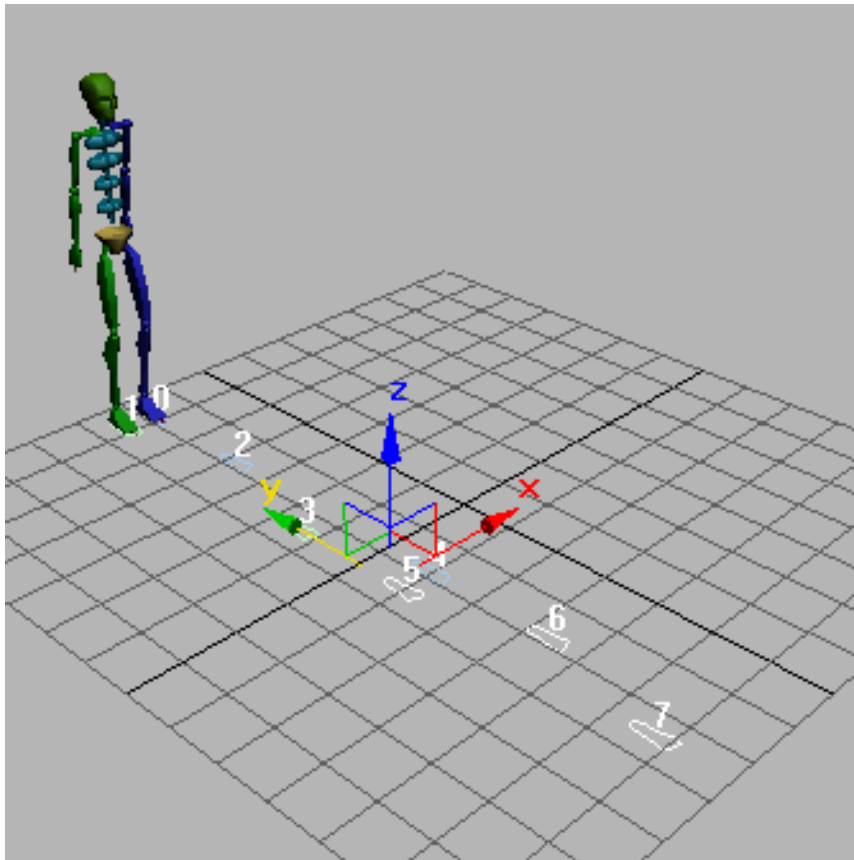

- 8 Play the animation to observe the change.
The animation looks a little funny right now; something's not quite right.
It's good practice to deactivate the footsteps, and then create new keys from the moved footsteps. This will recreate the correct upper body motions. You'll do that next.

Create keys to correct upper body motions:



- 1 In the viewport, select footsteps 4–7. On the Motion panel, in the Footstep Operations rollout, click Deactivate Footsteps.

To manipulate the footstep keys, you'll use Track View in Dope Sheet mode.

- 2 On the 3ds Max menu bar, choose Graph Editors > Track View - Dope Sheet.

The Dope Sheet opens.

- 3 In the controller window, expand the *Bip01 Footsteps > Transform* track, and click to highlight it.

You should see the footsteps in the keys window.

- 4 Right-click the top of the Track View window and choose Dock > Bottom. The Dope Sheet moves out of the way of the viewport.

- 5 Make adjustments as needed to your viewport so you have a clear view of the footsteps and the biped. When you select footsteps in the viewport, you also select footstep keys in Dope Sheet.

- 6 Select footsteps 4–7 in the viewport, if they aren't already selected.

In the Dope Sheet, the selected keys appear in a brighter color, with white dots on them.

- 7 Hold down the ALT key and click the white dot at the left side of footstep key 4. This deselects the left side of that footstep key. Repeat for key 5, deselecting the left side of the key.

Keys 4 through 7 are selected, but keys 4 and 5 display only one white dot.

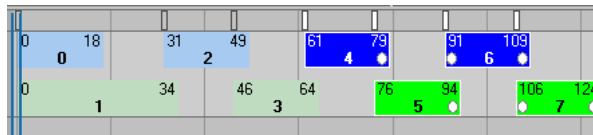

- 8 From the right side of key 5, drag to the right so the key ends at frame 200.

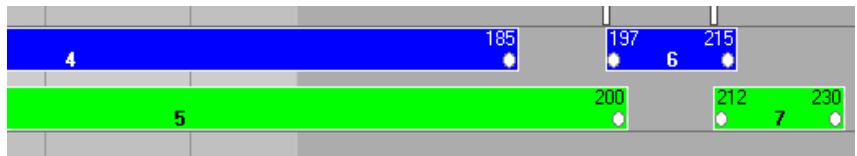

- 9 On the keyboard, press ALT+R to extend the animation to match the footstep keys.

Frames are automatically added to the animation.

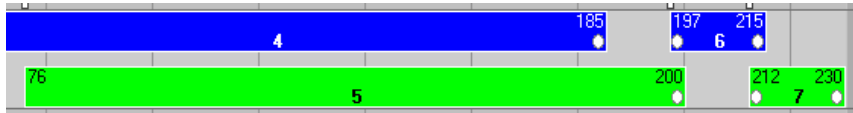

The light grey background extends behind the footstep keys. The time slider now shows that there are 230 frames in the animation.

- 10 Play the animation and observe the biped motion.

The biped walks, then stops and waits, and then walks again. The motion seems a bit odd, though, as he steps off around frame 180.

TIP There are a number of different ways to play and observe biped motion. One way is to drag the time slider to play the animation. For more control, press the < and > keys on the keyboard. This lets you stop instantly if you see a problem, and is more like a traditional animator flipping through the pages of drawings.

- 11  In the Footstep Operations rollout, click Create Keys For Inactive Footsteps.

- 12 Play the animation again.

The motion is better. When new keys are created, 3ds Max applies a new upper-body motion.

TIP For this reason, when you animate starting with footsteps, work out the foot motion before you worry too much about the upper body motion.

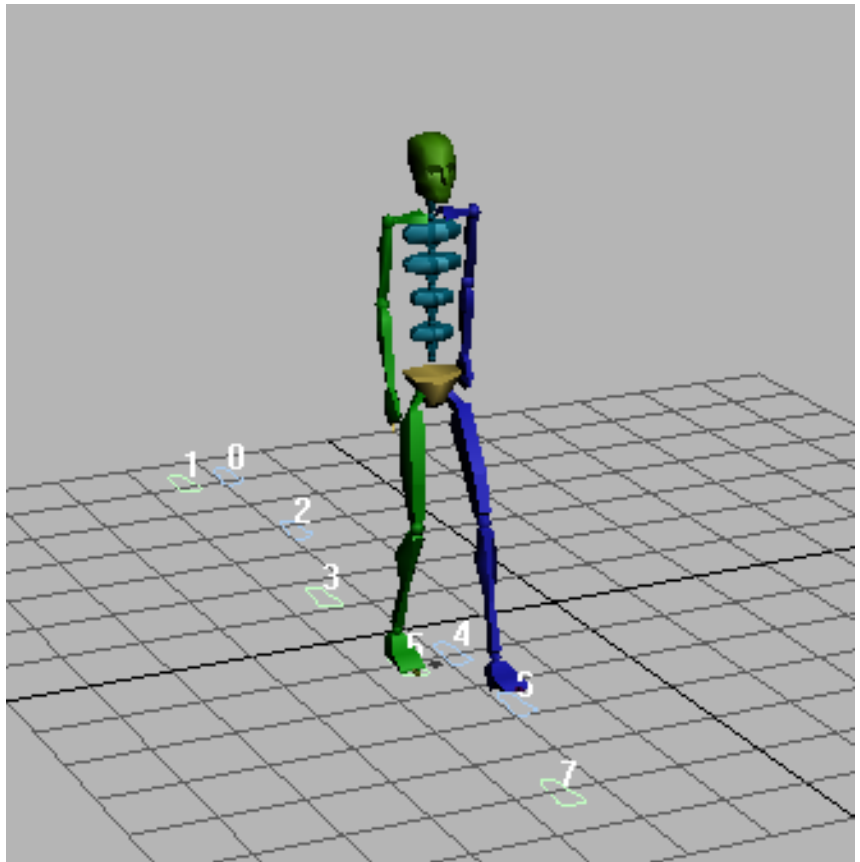

- 13 Save your work as **my_standstill.bip**, or open *standstill_final.max* to check the completed file.

Changing Footsteps Using IK Keys

Footstep and Freeform modes both use the same underlying *inverse kinematics (IK)* to animate the biped skeleton. Footstep gizmos are a method for manipulating sequences of IK keys.

With inverse kinematics, you animate a hierarchy, such as a biped's leg, by animating a lower link in the hierarchy: for example, the biped's foot. Inverse kinematics is the opposite of *forward kinematics*. Forward kinematics doesn't use the hierarchy; for example, you might animate a leg by rotating the thigh.

In this lesson, you'll learn how changing the IK keys affects the footsteps.

Set up for this lesson:

- Open *footsteps_keys_start.max*.
A biped is displayed with four footsteps in the viewport.

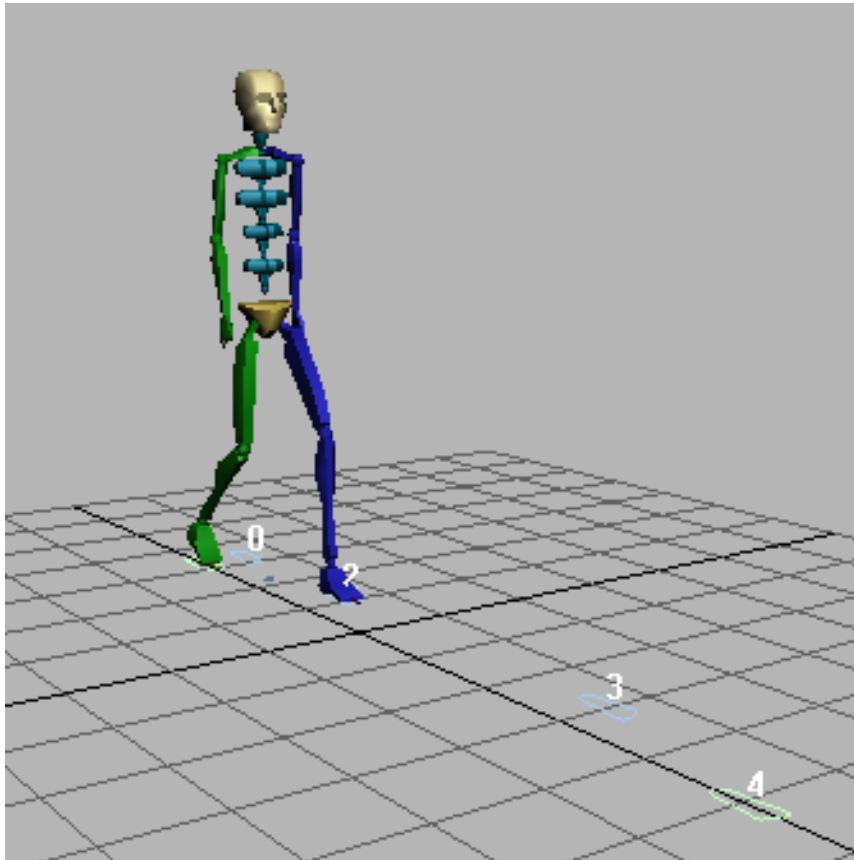

Set IK Keys to create footsteps:

- 1 Drag the time slider to play the animation.
The biped hops on his right foot. Notice that there is no footstep for the right foot between footsteps 2 and 3.

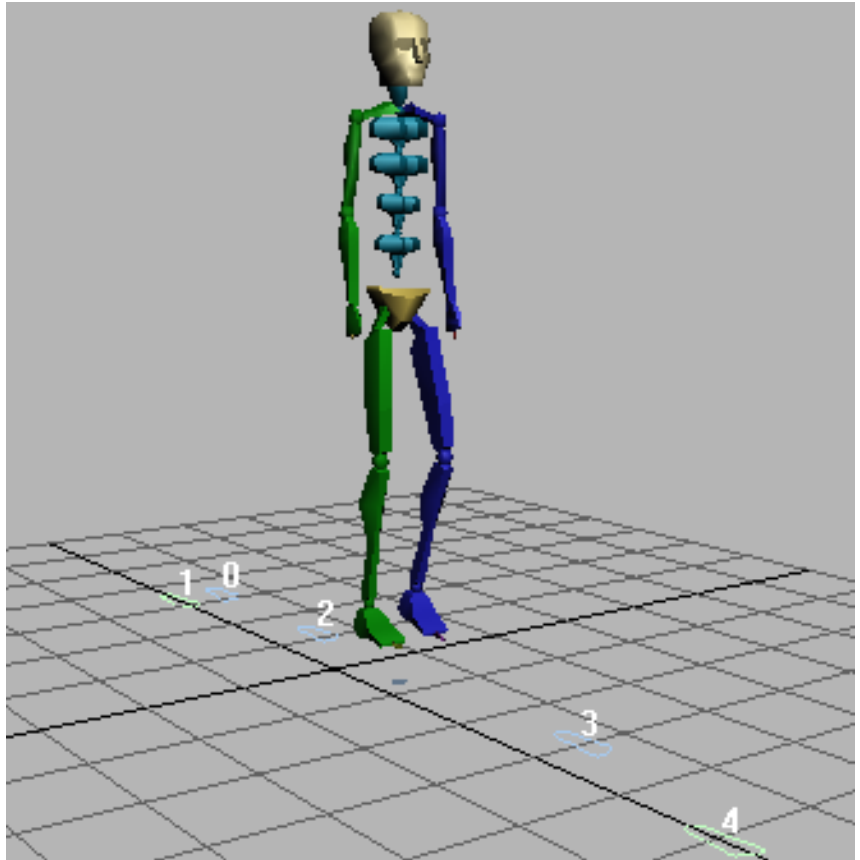





2 At frame 45, select *Bip01 R Foot*.

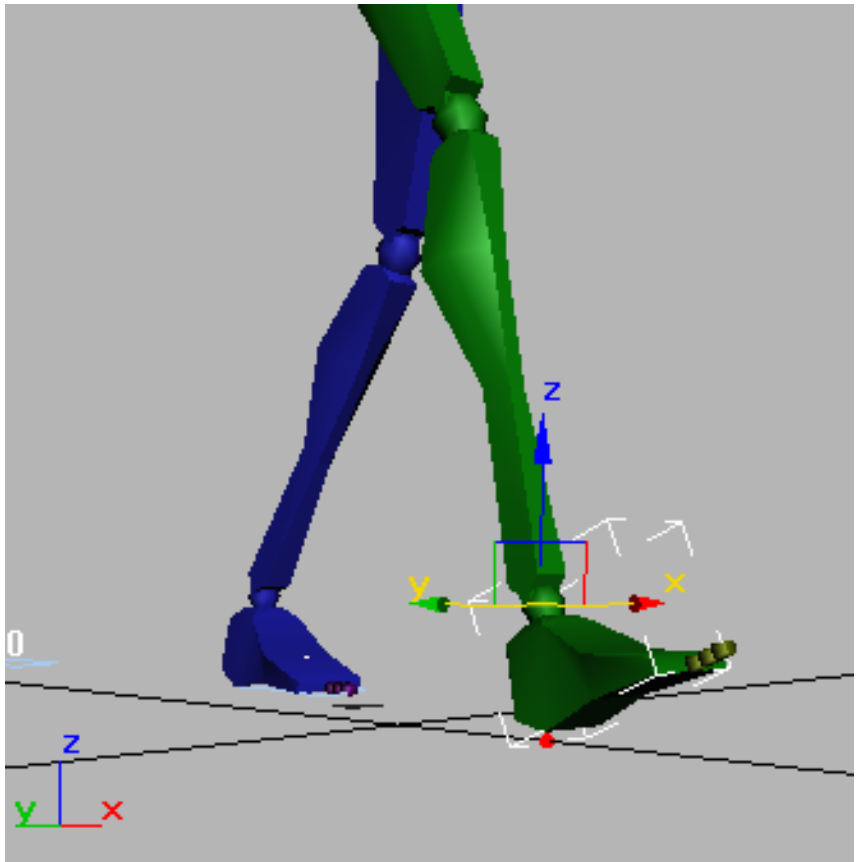

3 In the Key Info rollout on the Motion panel, click Set Planted Key.



The pivot point is displayed in the viewport. If you can't see it, change to Wireframe viewport shading, or navigate the viewport so you can see beneath the heel.

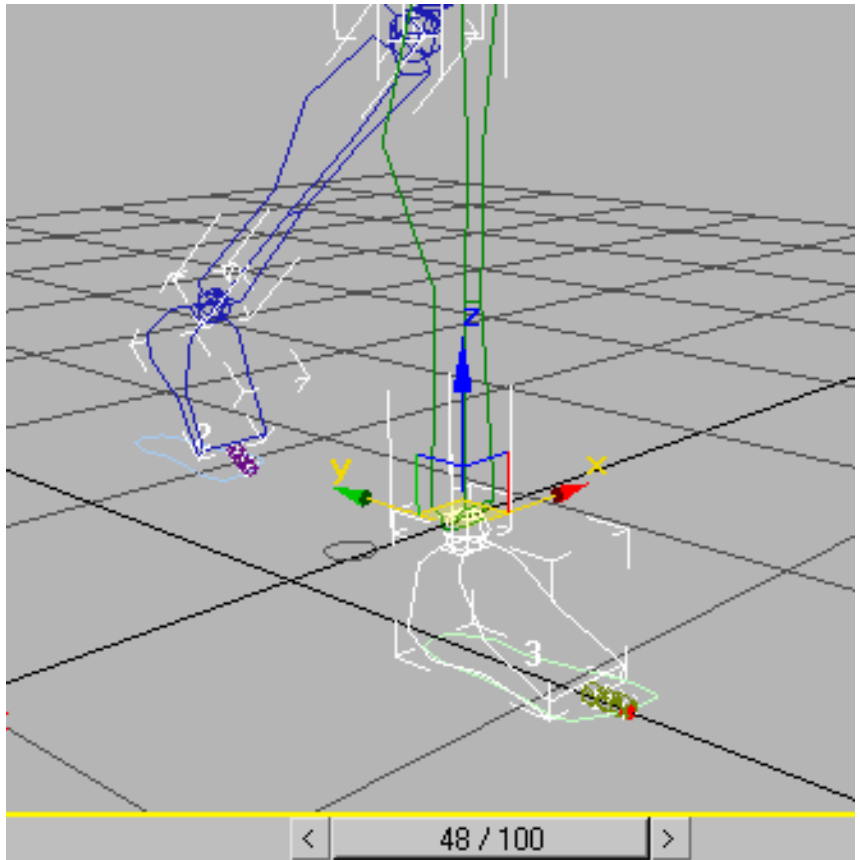

- 4  On the 3ds Max status bar, turn on Key Mode Toggle.
- 5   Click Next Key to go to frame 48, and then click Set Planted Key.
The pivot point shifts to the toe.



Note that the lowest IK pivot is selected by default for cases where IK is applied to new keys.

- 6   At frame 54, click Set Planted Key.

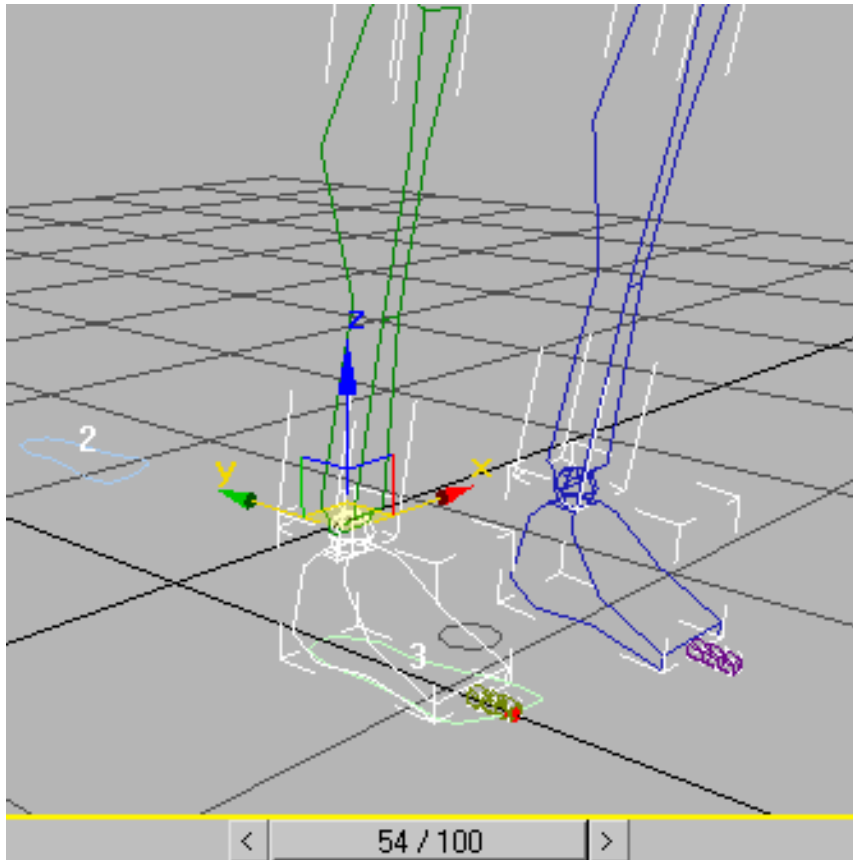

The biped is moved back to the ground. A footstep is displayed beneath the biped's foot.

A footstep has been created, because there is now an interval of time where IK is applied between the two planted IK keys. However, if you drag the time slider to play the animation, you will see that the walk still needs work.

Change the duration of footsteps using IK keys:



- 1 At frame 60, click Set Planted Key.
- 2 Play the animation now. The walk cycle is much better.

- 3 Right-click the foot and choose Dope Sheet.



- 4 On the Dope Sheet tool bar, turn on Edit Keys if it is not on already.



- 5 In the Biped rollout, turn on Footstep Mode to easily locate the track in Dope Sheet.

- 6 Expand the *Bip01 Footsteps > Transform* track. Notice that footstep 3 extends for 15 frames, from frames 45 to frame 60.



- 7 Turn off Footstep Mode.

- 8 Select *Bip01 R Foot* once more.

The keys for the foot are displayed in the Dope Sheet



- 9 At frame 63, set another planted key.



- 10 Turn on Footstep Mode.

The Dope Sheet editor again displays the Footsteps track.

The duration of the footstep now is 18 frames, from frames 45 to 63.

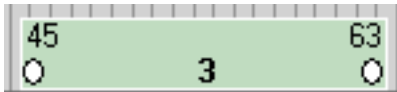

- 11 Turn off Footstep Mode.

- 12 Close the Track View - Dope Sheet window.

Remove footsteps using IK keys:

By editing IK keys, you can remove footsteps as well as add them.

-  1 At frame 45, select the *Bip01 R Foot* object in the viewport, then set a free key.

-  2 At frame 48, set a free key.

-  3 At frame 54, set a free key.

NOTE The body vertical position is modified. The biped now floats up into the air at frame 54.

-  4 At frame 60, set a free key.

The footstep disappears.

There is only one IK key left. With no IK interval defined, there is no duration, and therefore no footstep. The result is that the biped hops between footsteps 2 and 3.

The animation could be made more realistic by adding arm movement to the hopping steps, or by creating a freeform period for the hop, then adding poses for a crouch, spring and landing. The point of this lesson, however, has been to demonstrate that footsteps can actually be created or removed by changing the IK keys.

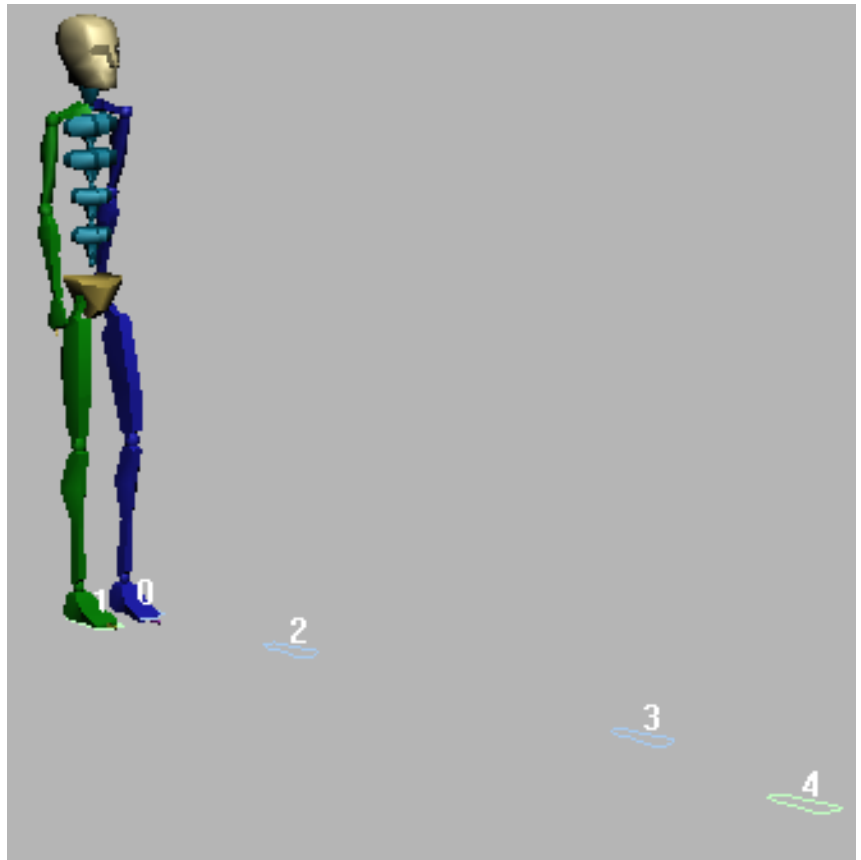

Summary

In this tutorial, you learned how to animate a biped using footsteps, add upper-body freeform animation, and how to modify the footsteps to make the biped, walk, run, and jump. You also learned how to change the duration of a footstep animation using IK keys.

Animating with Freeform

This tutorial shows you how to animate a biped using the freeform technique. This method does not use footsteps; instead, you are responsible for animating

every part of the biped. Freeform animation gives an animator fine control over the biped's motion.

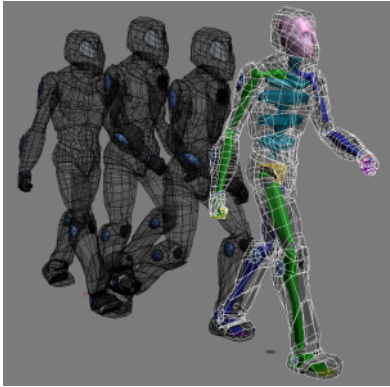

In this tutorial, you will learn how to:

- Use planted, sliding, and free keys.
- Create a traditional walk cycle using animated pivot points.
- Create a stretchy leg and a shaky walk using Biped SubAnim controllers.
- Create animated 3ds Max bones from a biped animation.

Skill level: Beginner to Intermediate

Time to complete: 2 hours

Creating a Simple Freeform Animation

This lesson provides an introduction to using freeform animation techniques with Biped.

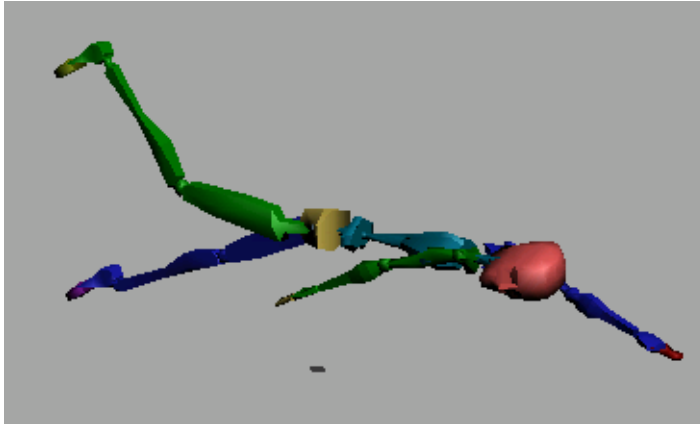

In this lesson, you will animate a biped swimming in place. You'll use freeform animation methods to produce the kicking legs and arm strokes.

In order to create this motion, you'll use a combination of rotations and moves. You'll also make use of Copy and Paste Posture Opposite to animate one arm and copy its tracks to the other.

Set up the lesson:

- 1 Reset 3ds Max.

- 2  On the Create panel, click the Systems button.

Create a biped and load a FIG file:

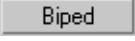
- 1  Click the Biped button and then create a biped in the Front viewport.

- 2  Go to the Motion panel.

- 3  Turn on Figure Mode and click Load File. The Open dialog displays.

- 4 Open the file *cs4_tut_rtgame.fig*. This file is in the folder `\sceneassets\animations\`.

The biped takes on new structural elements saved in the FIG file. This simplified figure has one large toe on each foot and one large finger on each hand, and its spine contains two segments instead of four.



The biped with FIG file applied.

- 5  Turn off Figure mode.

NOTE You cannot animate in Figure mode.

- 6  Select all the biped objects, and then click Zoom Extents All.
- 7 Save the scene as **MySwimmer01.max**.

Start a freeform animation:

You start a freeform animation by activating automatic key recording and transforming any part of the biped.

- 1 Right-click the Left viewport.

This activates the Left viewport without affecting the selection in the scene.

- 2 Press Alt+W to maximize the viewport for a closer view of the biped. The biped should be in wireframe. Change the shading display of the Left viewport if it is not wireframe.

- 3  Turn on Auto Key.
The button turns red, and the active viewport is outlined in red.

- 4  On the Track Selection rollout on the Motion panel, click Body Rotation.

NOTE Activating any of the Body ... buttons on the Track Selection rollout automatically selects the center of mass (COM) object.

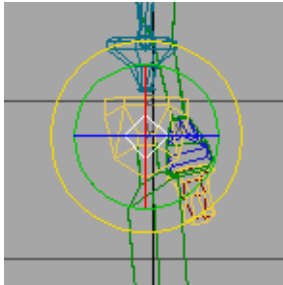

Rotation transform gizmo

The rotation transform gizmo lets you easily rotate an object about a chosen axis. As you move your cursor over the gizmo in the viewport, the axis circles turn yellow, indicating the axis around which the rotation will occur:

- The red circle, displayed as a vertical line in this viewport, affects the X axis.
- The green circle affects the Y axis.
- The blue circle, displayed as a horizontal line in this viewport, affects the Z axis.
- The light gray circle, displayed around the green circle, allows free rotation around all three axes.

- 5 Move your cursor over the green circle.
The cursor turns yellow, meaning that any rotation is locked to that axis.
- 6 Rotate the center of mass approximately 90 degrees about the Y axis.
Watch the coordinate readout near the gizmo to see how far you're rotating the biped. Rotate until the biped is lying prone.

TIP If you like, you can press A to turn on Angle Snap, which lets you easily rotate to 90 degrees.

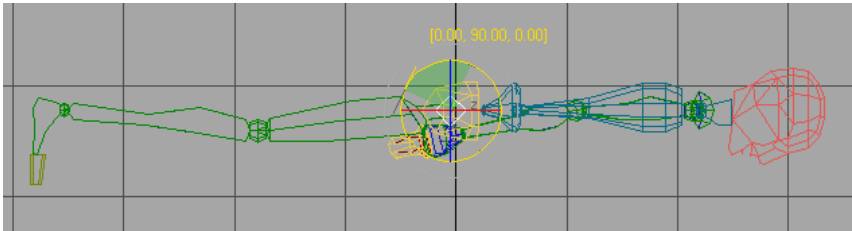

An animation key appears at the far left of the track bar, at frame 0.
You can select all three COM tracks under Track Selection to create keyframes simultaneously. Try this:

- 7  On the Track Selection Rollout, click Lock COM Keying, and then click the Body Rotation button.

- 8  On the Track Selection rollout click both the Body Horizontal and Body Vertical buttons so that both tracks are selected.

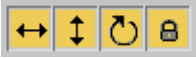
 All the multiple tracks for the COM are now active.

- 9  Expand the Key Info rollout and click Set Key.

This sets keys for all the COM tracks at frame 0. The trackbar key shows a multi-color display, indicating that both position and rotation keys have been created.

- 10 Click Lock COM Keying again to unlock the COM tracks.

TIP It's a good idea to set a key at the start of your animation for the three COM tracks.

Pose one leg:

Now that the biped is prone, you're ready to animate the swimming motion. First, you'll position the legs. You'll work on the right leg first, setting up its position at frame 0.

- 1 Press Alt+W so you can see all four viewports again.
- 2 Select *Bip01 R Thigh* by clicking the lines of the thigh in the Left viewport.

TIP As you hold your cursor over an object in the viewport, the object's name is displayed in a tooltip. You can also select an object by pressing H to choose objects from the selection list.



The right thigh is selected.

-
- 3 Rotate *Bip01 R Thigh* approximately -30 degrees about the Z-axis. The right leg is rotated, but the right foot is pointing straight down.

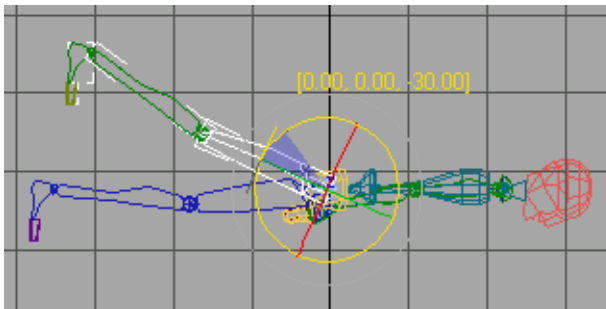

- 4 Press Page Down twice to select the right foot.

TIP The Page Up and Page Down keys let you quickly navigate through the objects that make up a biped.

- 5 Rotate *Bip01 R Foot* about -50 degrees around the Z-axis.

The foot looks more natural in this position.

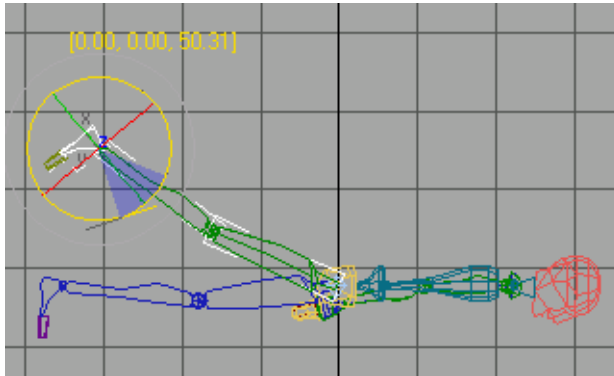

So far you've used only forward kinematics to animate the biped. Next you'll use inverse kinematics by moving the foot to move the entire leg.

- 6 Right-click the same foot and choose Move from the quad menu.

TIP You can choose the transform tools either from the main toolbar or by right-clicking to open the quad menu.

The Transform gizmo switches to an axis tripod showing two of three arrows in this viewport. They are displayed at right angles with the Z axis pointing up and the Y axis pointing left.

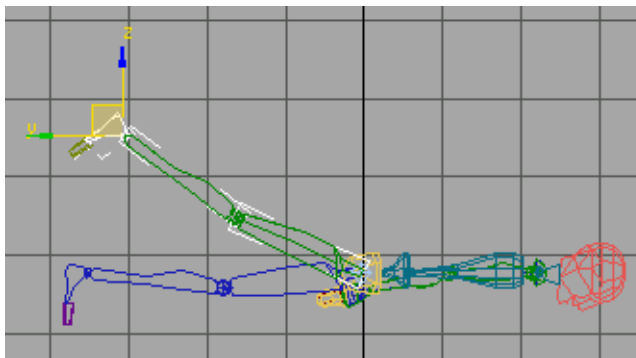

Ready to move the foot.

- 7 In the Left viewport, move the cursor over the Y axis of the gizmo until it turns yellow, then move the foot a little to the right.

The knee bends to accommodate the new position of the foot.

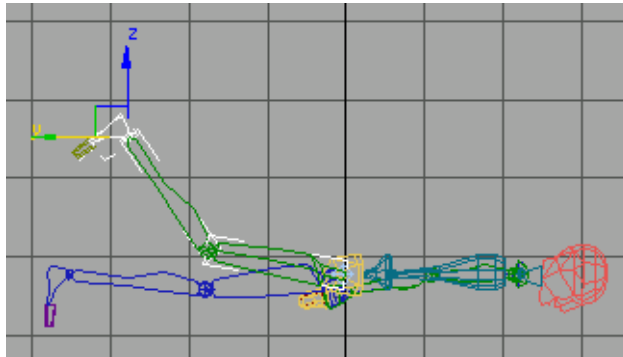

The knee bends.

In this move, you've just used *inverse kinematics*. The foot, calf, and thigh are linked together in a hierarchical chain. By moving the end of the chain, the foot, you rotated the lower and upper leg objects.

- 8 Save the scene as **MySwimmer02.max**.

Animate the leg:

Everything you've done so far has been at frame 0. Now you'll move forward in time and animate the pose at frame 10.

- 1 Move the time slider to frame 10.
- 2 Move the foot downward on the Z axis until the knee straightens out.

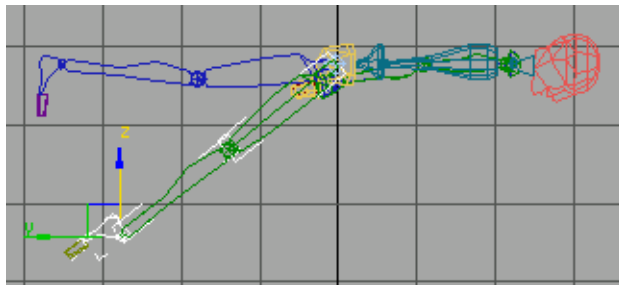

- 3 Press Page Up twice to select *Bip01 R Thigh*.
- 4 Right-click and choose Rotate from the quad menu, then rotate the *Bip01 R Thigh* approximately -10 degrees about the Z axis.

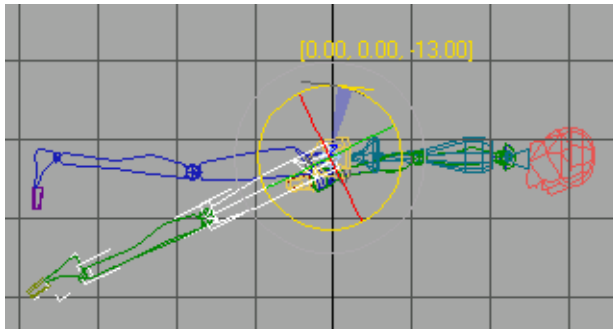

Rotating the thigh.

- 5 Move the time slider back and forth between frame 0 and frame 10.
The leg moves up and down.

Use copy and paste:

Now you'll use some specialized Biped tools to pose and animate the opposite leg.

- 1 Return the time slider to frame 10.
- 2 Double-click *Bip01 R Thigh*.
The entire leg is selected from the thigh down to the toes.

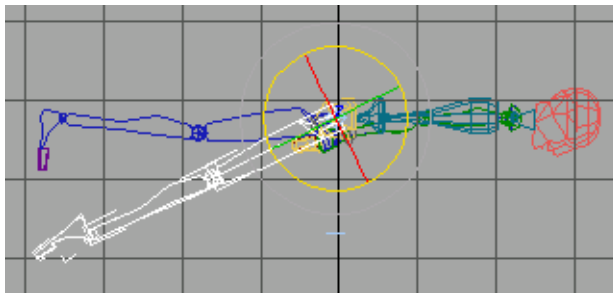

- 3 On the Motion panel, expand the Copy/Paste rollout.
The Copy/Paste functionality includes the creation of collections. You must create a collection before you can start creating postures.

- 4  On the Copy/Paste rollout, click the Create Collection button. This creates a collection named *Col01*. Rename it to **Swim – Crawl**.

- 5  Make sure that the Posture button is activated.

- 6  Also make sure that Capture Snapshot From Viewport is chosen, just above the Paste Options group. This forces the thumbnail of the pose to be taken from the active viewport. This particular posture, for example, is better seen from the Left viewport rather than the Front.

- 7  Click Copy Posture.

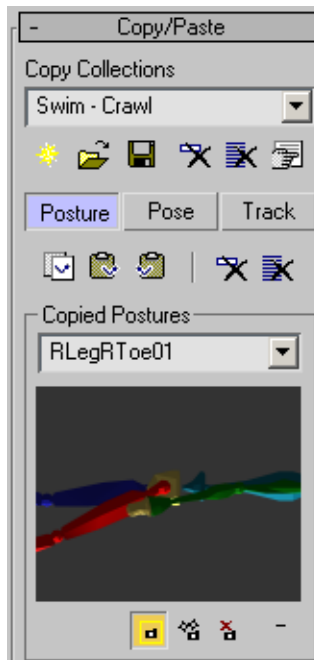

The posture of the right leg is copied into a buffer. Change the name of the Copied Posture to **RLeg – downkick**.

- 8  Move the time slider back to frame 0. Click Paste Posture Opposite. The left leg rotates downward. The right leg hierarchy is still selected.

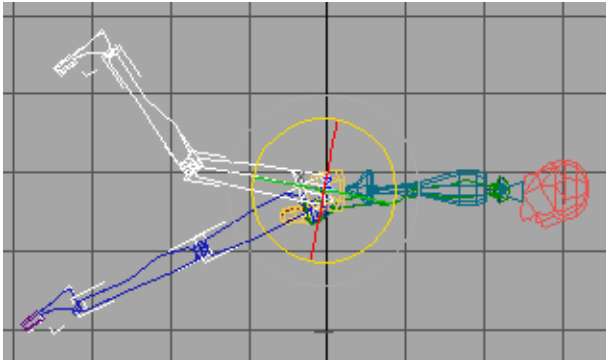

- 9  At frame 0, choose Copy Posture again.

- 10 Move the time slider to frame 10.

- 11  Click Paste Posture Opposite again.
Now the left leg is raised, and the right leg is down.

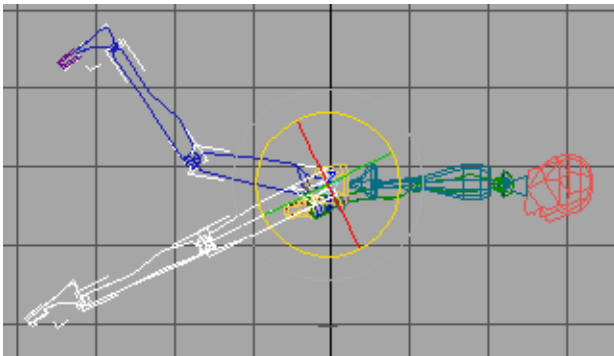

- 12 Move the time slider back and forth between frames 0 and 10 and watch the legs kick.
Now you'll repeat this process to make the legs kick several times.
- 13 Save the scene as **MySwimmer03.max**.

Use Paste Posture to create multiple kicks:

You can use the Copy Posture tools to quickly duplicate all the leg keys from one frame to another to create repeated kicking motions.

- 1  Make sure that Auto Key is still on and move the time slider to frame 0.

- 2  On the Track Selection rollout, click Symmetrical.
Now both legs are selected.

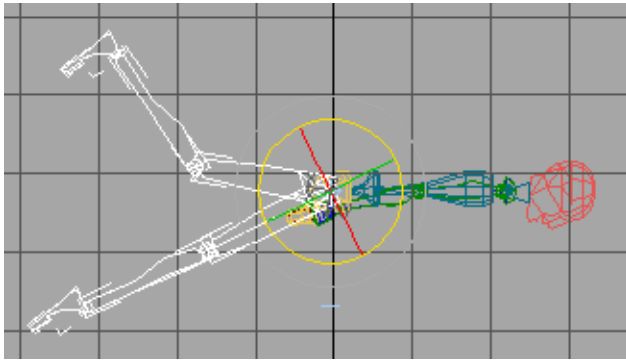

- 3  Click Copy Posture at frame 0. Name the copied posture **R up L down**.

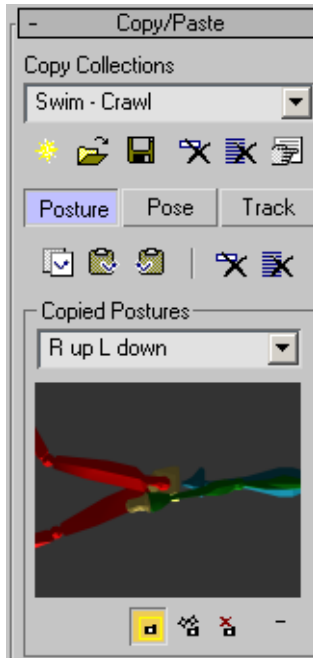

Both legs are added to the collection.

- 4 Move the time slider to frame 20.

TIP You can type in the frame number in the Current Frame time control.



- 5  At frame 20, click Paste Posture.
- 6 Go to frame 30 and click Paste Posture Opposite. From this point forward you can click either Paste or Paste Opposite as you create a kicking cycle. For a smooth kick cycle, simply alternate the posture every 10 frames up to frame 80. The track bar displays a total of nine keys for the animation of the legs.



- 7 In the Copy Collections group click the Save Collection button to save your collection. Name the collection **Swim – Crawl**. The CPY extension is automatically added to the name.
- 8 Save the scene as **MySwimmer04.max**.

Animating a kicking leg was fairly easy, requiring only two poses: one with the leg up, and one with the leg down. Animating the arms is more complex. To animate the stroke of an arm, you'll need five poses:

- The arm outstretched
- The arm down
- The arm back
- The arm drawn up out of the water near the ear
- The arm entering the water

When one arm is animated correctly, you'll use Copy Track and Paste Opposite Track to animate the second arm. You'll adjust the timing of the second arm by sliding the keys in the track bar.

Animate one arm:

- 1  Make sure that Auto Key is still on, and move the time slider to frame 0.
- 2 Press H and select *Bip01 L UpperArm* from the Select From Scene dialog.
- 3  In the Left viewport, select and rotate *Bip01 L UpperArm* approximately -160 degrees about the Z axis, until it is extended in front of the biped.

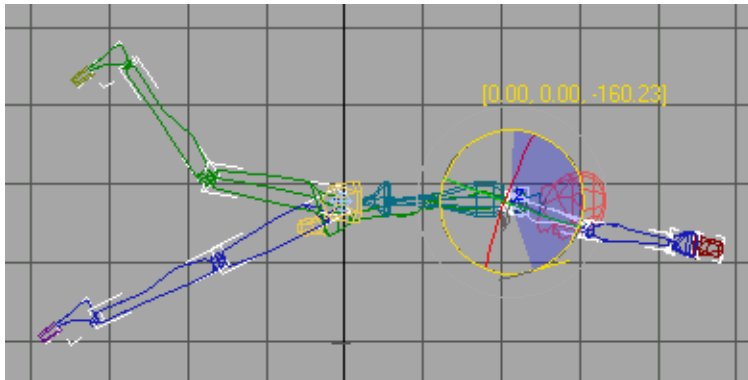

- 4 Right-click the Top viewport and press Page Up to select *Bip01 L Clavicle* and rotate it -20 degrees about the Y axis.

This should prevent the arm from passing through the head.

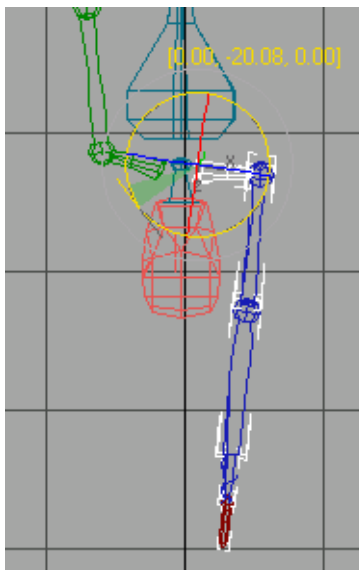

- 5 In the same viewport, press Page Down three times to select *Bip01 L Hand*. Rotate it approximately -90 degrees about the X axis so the palm is facing down.

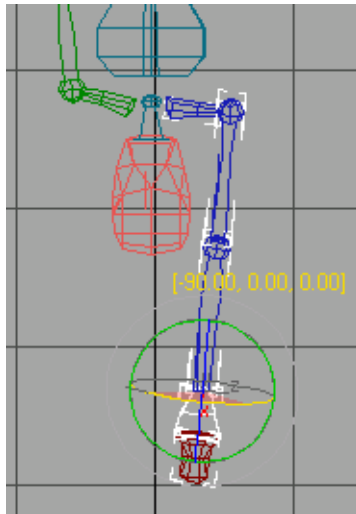

This completes the first arm pose, so it's a good time to save your data.

- 6 Double-click *Bip01 LClavicle* to select the entire left arm hierarchy.
- 7 Activate the Perspective viewport so that the snapshot will be easier to identify, and then click Copy Posture. Name the pose **LArm extended**.

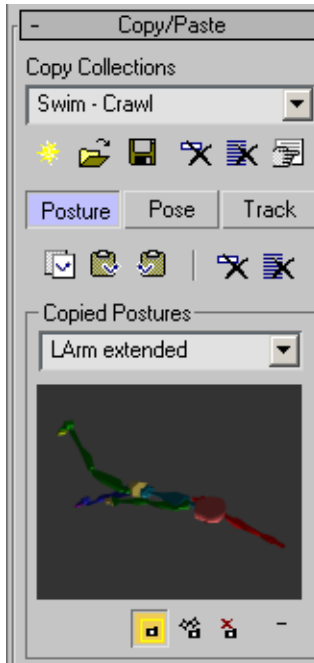

Thumbnail snapshot from perspective viewport.

- 8 Move the time slider to frame 10.



- 9 On the main toolbar, click Select And Move, and then change the Reference Coordinate System to World if necessary.

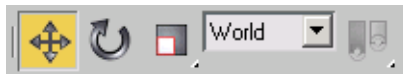

This will facilitate working with the Transform gizmo in different viewports.

- 10 Right-click in the Left viewport. Move *Bip01 L Hand* downward on the Y and Z axes until it points straight down. This completes the second arm pose.

TIP If you grab the Move gizmo by the corner where the two axes meet, you can move selected objects on both axes at once; that is, on the YZ plane.



- 11 Double-click *Bip01 LUpperArm* to select the arm hierarchy and then click Copy Posture. Name the pose **LArm down**.
- 12 Move the time slider to frame 20.



- 13 Select *Bip01 L Hand* and then move the hand along the Y axis toward the legs.

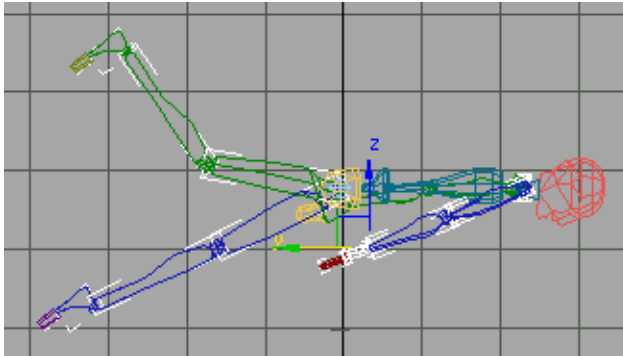

- 14 Activate the Front viewport and press Page Up three times to select *Bip01 L Clavicle*. Rotate this part about 24 degrees around the Z axis. This completes the third arm pose. Save it by double-clicking *Bip01 L UpperArm* in the Top viewport to select the hierarchy, then click Copy Posture. Name the pose **LArm back**. If you activate the Perspective viewport

before you copy the posture, you can adjust the viewport so the pose is clearly visible in the thumbnail.

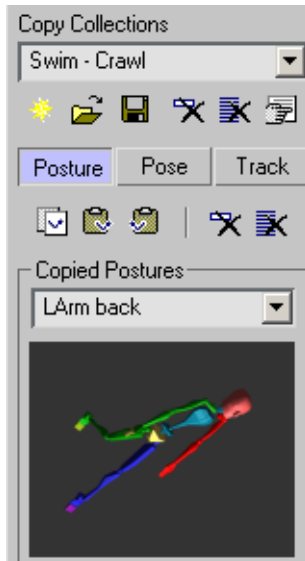

15 Move the time slider to frame 30.

16 Activate the Top viewport.



17 Select *Bip01 L Hand* and then move the hand in the XY plane until the hand is level with the shoulder.

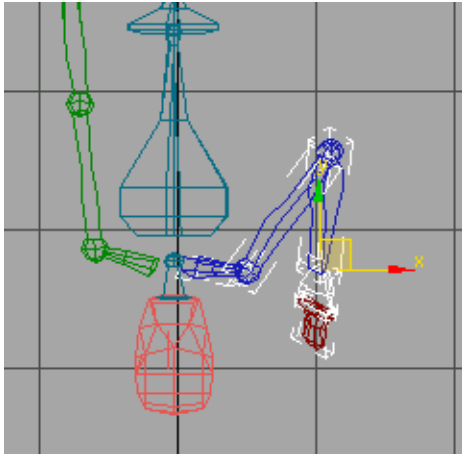

- 18 In the Left viewport, move *Bip01 L Hand* on the Z axis so it is near the ear.

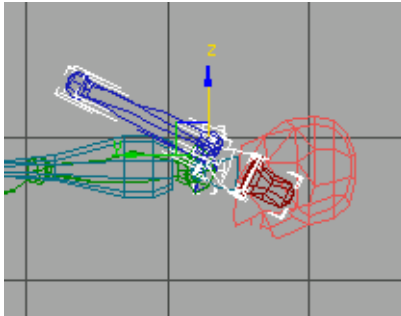

- 19 Finally, rotate *Bip01 L Hand* about the X axis so the palm is flat. This completes the fourth arm pose. Save it to the collection by double-clicking the upper arm to select the entire hierarchy, then click Copy Posture. Name it **LArm up**.

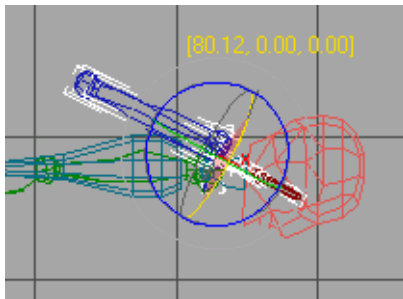
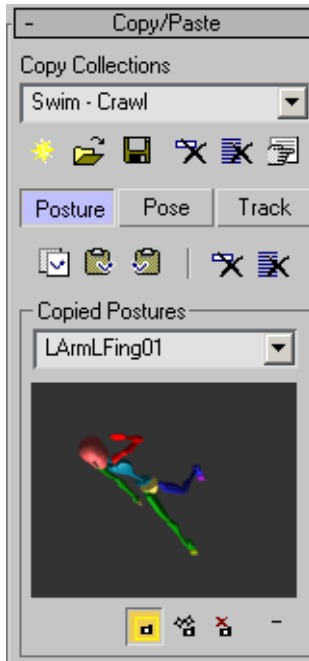

- 20 To create the fifth pose go to frame 37.
- 21 In the Left Viewport, move the *Bip01L Hand* object on the Y axis so it is in front of the head, and is level with the shoulders. Double-click the *Bip01 L Upperarm* to select the entire arm hierarchy, activate the Perspective viewport, and then click Copy Posture. Name the posture **LArm stroke**.

NOTE The fifth pose is used to ensure that the rotation of the arm is correct going from the out of water pose to the extended pose.

22 Save the scene as **MySwimmer05.max**.

Applying a twist pose:

You can use twist poses to correct upper arm rotations. Twist poses are primarily used to correct arm twisting, but in this case we'll use it to simply position the arm efficiently.

- 1 Turn off Auto Key if it is on.
- 2 Select *Bip01 L Upperarm*.
- 3 Move the time slider to frame 33.
- 4 Expand the Twist Poses rollout.
- 5 In the Twist Poses drop-down list, choose each pose and observe the change to the arm in the viewport.

Consider these default poses as additional copied postures that you can use to “straighten out” problems by defaulting to fixed rotations.

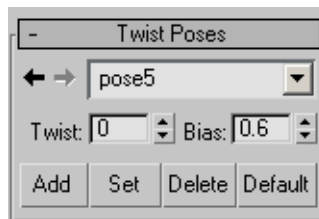

Twist Poses

- 6  When pose 5 is selected the arm will be rotated and positioned correctly. Expand the Key Info rollout and click Set Key to keyframe the twist pose.



Default Twist pose 5.

TIP Twist poses are designed to help you fix twisting that occurs in the mesh attached to the biped. If you go to Figure Mode, you can enable Twist Links by turning on the Twists check box, then set the number of twist links you would like for the upper arm, forearm, thigh, or “horse-link” (the extra link in the Leg if Leg Links are set to 4). Unfreeze and unhide all and you will be able to see the twist bones that have been added using this method. Once the Twist Links functionality is enabled you can play with the Twist and Bias settings.

Copy the Arm pose:

To complete the arm cycle, in the next few steps you’ll copy the arm pose to frame 40.

- 1  Turn on Auto Key.
- 2 In the Top viewport, double-click *Bip01 L Clavicle* to select the entire left arm.

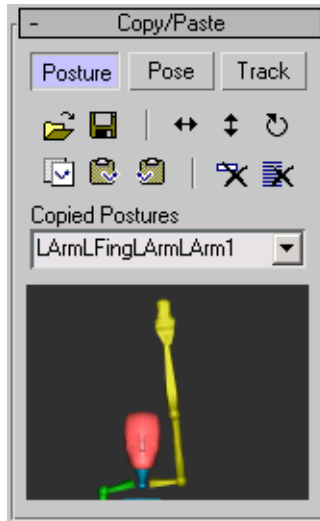

3  At frame 33, click Copy Posture.

4  Advance the time slider to frame 40 and click Paste Posture.

If you see any unusual rotations or out-of-place movements, you can set additional keys to refine the animation.

5 Move the time slider and watch the animation.

Repeat the animation:

If the animation is going to be 80 frames in length, you'll need to repeat the arm movement.

- 1 Double-click *Bip01 L Clavicle*, to select the entire left arm, if it's not already selected.
- 2 In the trackbar drag a selection window around the keys for frames 10 through 40.
- 3 Hold down the Shift key and copy these keys by dragging them to the right. When the first key is over frame 50, release the mouse button.

- 4  Play the animation. The biped should perform two complete strokes with its left arm.
- 5 Save your scene as **MySwimmer07.max**.

Add rotation to the spine:

Next you'll add some rotations for the spine to make the animation more convincing. This spine of this biped figure (*cs4_tut_rtgame.fig*) has only two segments. You'll rotate the large section representing the upper torso.

- 1 Make sure that Auto Key is still on.
- 2 Select *Bip01 Spine1*.

NOTE The first spine object is *Bip01 Spine*. The large second spine object is *Bip01 Spine1*.

- 3 Right-click the Front viewport.



- 4 Move the time slider to frame 0, and on the Key Info rollout, click Set Key.
This sets a start key for the rotation.
- 5 Move the time slider to frame 10 and rotate *Bip01 Spine1* approximately **-15** degrees about the X axis.
This makes the body appear to follow the movement of the arm.

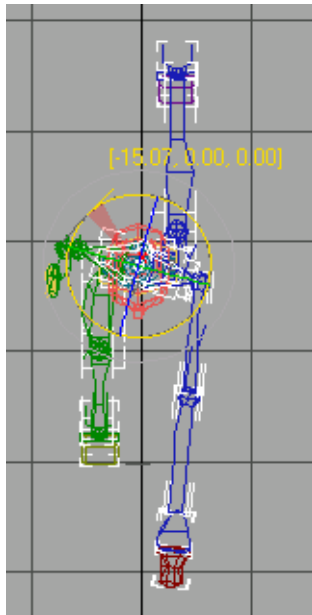

Spine rotation

- 6 On the track bar, click the key at frame 0 to select it, then hold down the Shift key and drag a copy to frame 30. Watch the status area to know when you are at frame 30.



The spine now rotates once in the 40-frame cycle.

- 7 Select *Bip01 Pelvis*.



- 8 Move the time slider to frame 0 and on the Key Info rollout, click Set Key.

This sets a start key for the rotation.

- 9 Move the time slider to frame 10 and rotate the pelvis a few degrees in X so it follows the movement of the left leg.

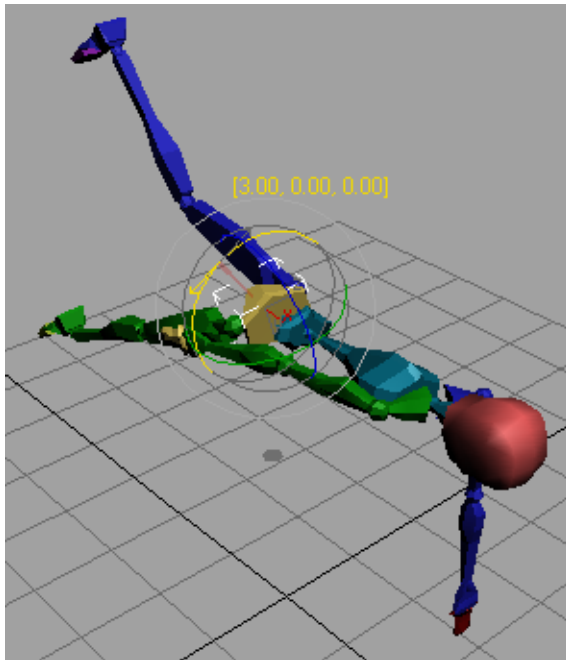

Rotate the pelvis.

- 10 Copy these two keys to frames 20 and 30.

TIP You can also add a few degrees of rotation around the Y axis as well for the pelvis if you like.

Next you'll copy the pelvis and spine rotation keys to repeat the motion.

- 11 Make sure that the pelvis is still selected, then hold down the Ctrl key and click the *Bip01 Spine01* object (the large torso spine object).
- 12 In the track bar, drag a selection rectangle around the four visible keys.
- 13 Hold down the Shift key and drag the keys so the leftmost key is copied to frame 40. Move the time slider back and forth to see the animation.
- 14 Copy the key from frame 0 to frame 80 to complete the set of keys.

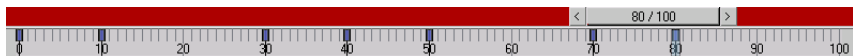

The final set of Bip01 Spine1 keys.

Animate the head:

The biped can breathe as it swims, if you animate the head rotation appropriately.

- 1 In the Left viewport, select the biped's head, *Bip01 Head*.
- 2 Move the time slider to frame 0 and rotate the head about **70** degrees around the X axis, so the biped's left ear is pointing down.

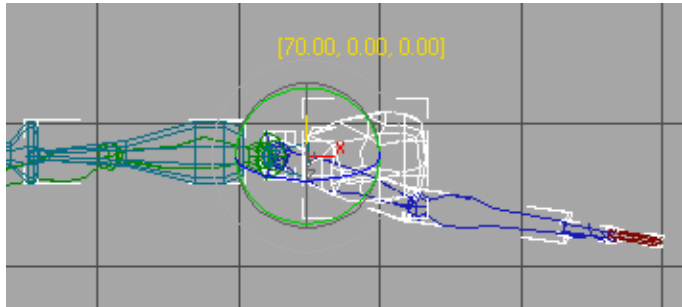

Rotate the head for breathing motion.

TIP Watch the Perspective viewport while rotating in the Left viewport.

- 3 At frame 20, rotate the head back down.

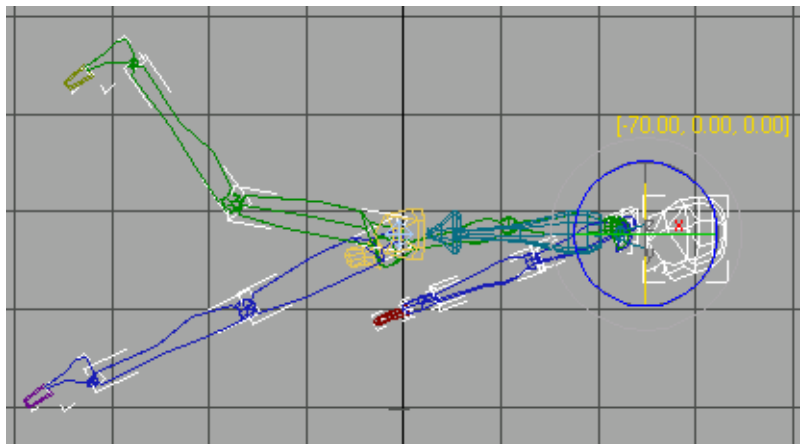

- 4 Hold down the Shift key and drag to copy the key at frame 0 to frame 40. Watch the status area to know when you are at frame 40.

- 5 Move the time slider to observe the head rotation.
Actually, it would look better if the head were turned up at frame 30.
- 6 Slide the key you made at frame 20 along the track bar to frame 30. Do not hold down the Shift key for this step.
The biped lifts and lowers its head once in the 40 frame cycle.

TIP You can move the time slider to frame 30, then slide the key on top of it.

- 7 To explore another way to copy keys, right-click the time slider.
The Create Key dialog is displayed. This lets you create keys by choosing a source and a destination.

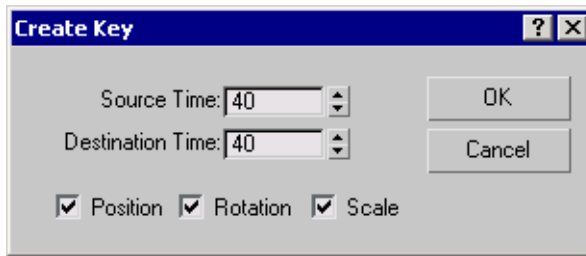

TIP You don't have to turn on Auto Key to set keys this way.

- 8 Set Source Time to 30 and Destination Time to 70, and then click OK.
- 9 Right-click the time slider again.
- 10 Set Source Time to 0 and Destination Time to 80, and then click OK.

This completes the head motion, but the right arm motions still need work. That comes next.

Animate the other arm with Copy Tracks:

Copy Tracks lets you copy and paste the animation tracks of selected objects to other objects, or to opposite body parts.

- 1  Make sure that Auto Key is still on.
- 2 In the Top viewport, double-click *Bip01 L Clavicle* to select the entire left arm.

3 Activate the Perspective Viewport.

4  On the Copy/Paste rollout, turn on the Track button.

5  Click Copy Track.

The track is copied to the buffer. Name the track **LArm - Crawl**.

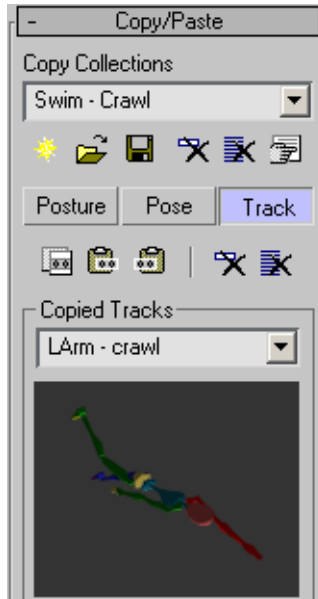

6  Click Paste Track Opposite.

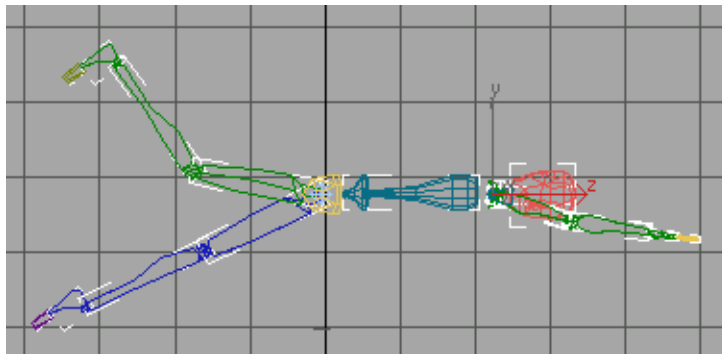



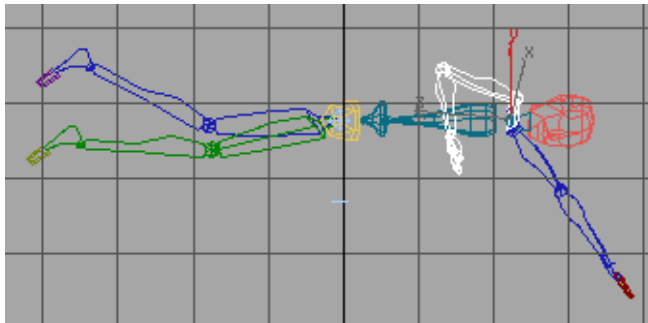

- 7  Play the animation.
The biped is swimming the butterfly stroke. The two arms move together. Next you'll change the timing so the arms alternate.
- 8 In the Top viewport, double-click the *Bip01 R Clavicle*.
The entire right arm is selected in the viewport.
- 9 Drag a box around all the keys in the track bar to select them. Slide all the keys 20 frames to the right.



The biped swimming a freestyle stroke.

- 10  Play the animation.
Now the beginning and end are not quite right. The easiest way to correct this is to copy and paste poses.

Fix the beginning and end:

- 1  Make sure that Auto Key is still on.
- 2 In the Top viewport, double-click the *Bip01 R Clavicle* to select the entire right arm, if it's not already selected.
- 3  On the Copy/Paste rollout, click the Posture button.
- 4  Move the time slider to frame 50 and click Copy Posture.
- 5  Move the time slider back to frame 10 and click Paste Posture.

- 6 At frame 40, click Copy Posture, then at frame 0, click Paste Posture.
Now the arms alternate.

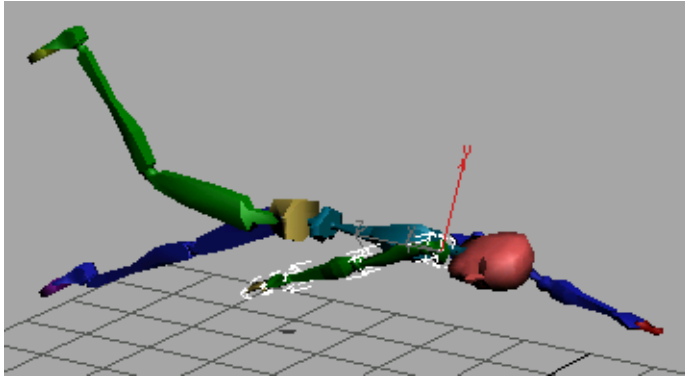

To correct the other end of the animation, you can crop the animation to 80 frames.

- 7  In the time controls, click Time Configuration.
The Time Configuration dialog is displayed.

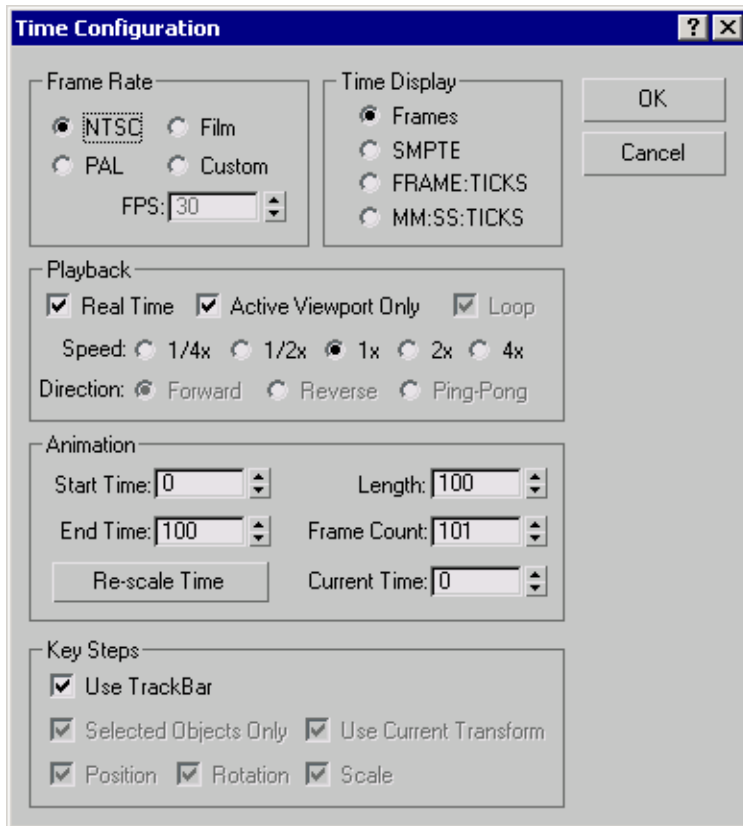

- 8 In the Animation group, change the End Time to **80**. Click OK.

WARNING Do not click Re-scale Time.

- 9  Play the animation.

Save your work:

- 1  In the Biped rollout, click Save File and save the motion as **MySwimmer.bip**.
- 2 Also save your final scene as **MySwimmer08.max**.

Perfecting the animation:

- If you like, you can improve the animation by adding some rotation keys to the pelvis and spine and by adding secondary motion to the feet and hands. Stagger the rotations of the extremities a few frames following the movement of the hands and feet.

Animating a Freeform Walk Cycle

While 3ds Max has a dedicated method (Footstep mode) for creating quick and easy walking animations, you can also create walk cycles with freeform animation.

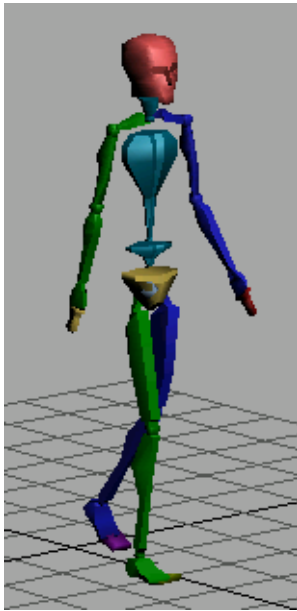



In this lesson, you'll use animated pivot points and IK blend keys to constrain the feet to the ground plane.

Set up the lesson:

- 1 Restart or reset 3ds Max.
- 2  On the Create panel, click the Systems button.

Create a biped and load a FIG file:

- 1  Click the Biped button and create a biped in the Front viewport.

- 2  Open the Motion panel.

- 3   Turn on Figure Mode and click Load File.
The Open dialog is displayed.

- 4 Open the file *cs4_tut_rtgame.fig*. This file is in the folder `\sceneassets\animations\`.

The biped takes on new structural elements stored in the FIG file. This simplified figure has one large toe on each foot and one large finger on each hand; its spine contains two segments instead of four.



- 5  Turn off Figure mode.

NOTE You cannot animate in Figure mode.

- 6  Click Zoom Extents All.
- 7 Save the scene as **mywalk01.max**.

Set a key:

- 1 Change the Perspective viewport to Wireframe (press F3) and zoom in so the feet are clearly visible.
- 2 Select *Bip01 R Foot*.

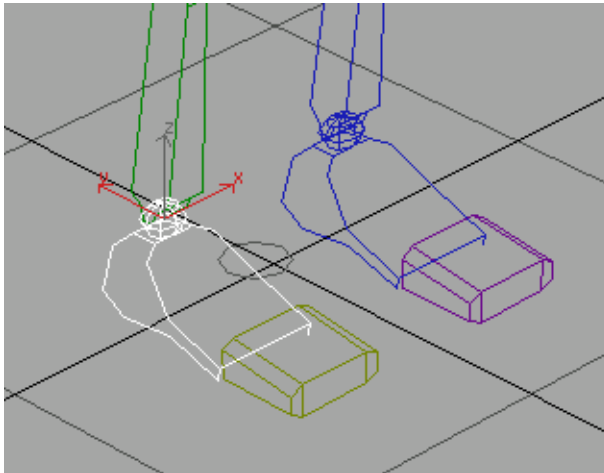

- 3  On the Motion panel, in the Key Info rollout, click Set Key. The foot is highlighted in white, and a key appears on the track bar at frame 0. You have just started a freeform animation.



Track bar key at frame 0

Set different types of keys at frame zero:

There are two ways to set character animation keys in 3ds Max. You can use the standard method of keyframing, which involves turning on Auto Key and

transforming objects. It is quick and easy, but if you forget that Auto Key is on, you can set keys unintentionally.

The second method uses the Set Key buttons on the Key Info rollout. These buttons set several parameters at once. This is the method you'll use in the steps that follow.

-  On the Track Selection rollout, click Body Vertical.
This selects the biped's center of mass, *Bip01*, and activates the Move tool in one step. You've set a key for the foot, but there is a problem. The foot can go through the ground plane. See for yourself in the next few steps.
- Right-click the Left viewport to activate it without changing the selection set.
- With the Body Vertical track still active on the Track Selection rollout, move the center of mass down in the Left viewport.
The biped moves down through the ground plane (as indicated by the grid in the Perspective viewport).
- Press Ctrl+Z to undo.

Set planted keys:

Now you'll set a planted key. A planted key does three things: it sets IK Blend to 1, turns on Join To Previous IK Key, and also turns on Object Space. Together, these three settings ensure that the foot will not pass through the ground plane.

For more information about IK Keys, refer to the "Key Info Rollout" topic in the User Reference.

- In the Perspective viewport, select *Bip01 R Foot* again.
-  On the Key Info rollout, click Set Planted Key.
The red pivot point becomes more pronounced.

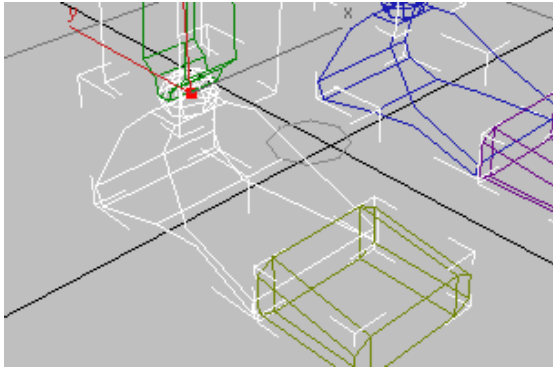

- 3 On the Track Selection rollout, click Body Vertical, and move the biped down in the Left viewport.

The foot stays on the ground plane, and the knee bends to accommodate the vertical movement of the biped.

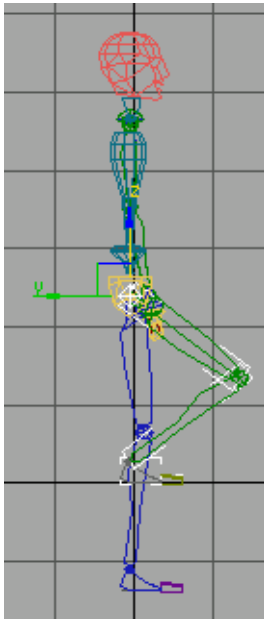

Planted foot stays on ground.

- 4 Press Ctrl+Z again to return the biped to its previous position.

Now you've seen the effect of the planted key on the foot. You can use the same Set Key buttons on pivot points for the feet and hands. Next, you'll replace the key at frame 0 with a new one, changing the pivot point.

Set pivot keys:

- 1 At frame 0, right-click the Perspective viewport and select *Bip01 R Foot*. It still has the planted key from before.
- 2 On the Key Info rollout, open the IK expansion bar and click Select Pivot. All pivot points for the foot are now visible as blue and red dots. The pivot at the ankle is red, showing that this is the currently active pivot point. Wireframe mode lets you clearly see and select the pivot points.
- 3 Click the pivot point on the ball of the foot, at the base of the toes. The new pivot point is displayed in red.

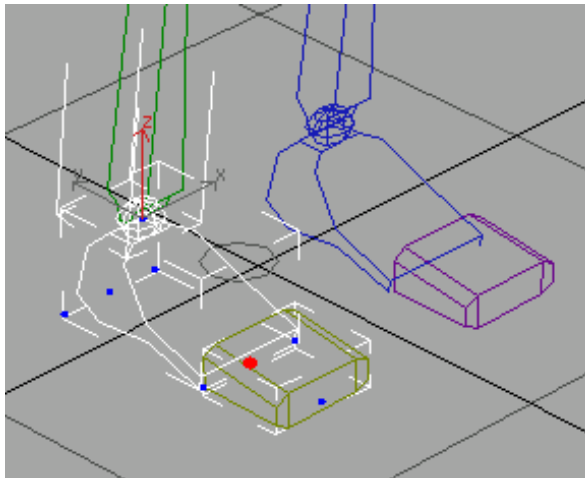

NOTE You don't have to set a key each time you choose the pivot point. However, you should use the Set Key buttons if you want to change the Key parameters.

- 4  Advance the time slider to frame 5, and click Set Key.

- 5 Right-click the foot and choose Rotate from the quad menu. On the main toolbar, make sure that Reference Coordinate System is set to Local.

- 6  Rotate the foot up approximately -15 degrees about the local Z axis to make the heel raise, and then click Set Planted Key.

The heel lifts off the ground, the foot rotates on the ball, and the toes stay on the ground.

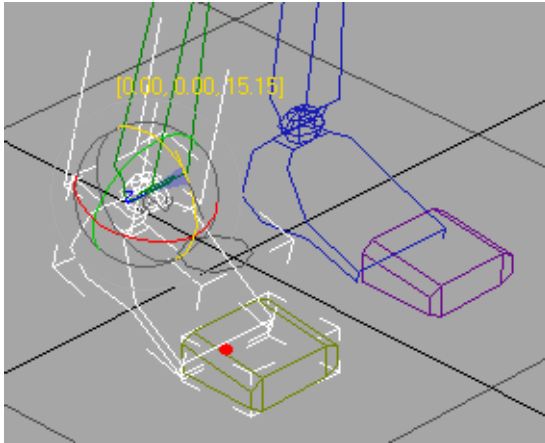

Now you can animate the pivot point to the toes, as the ball of the foot lifts off the ground.

Animate the pivot points:

- 1  Move the time slider to frame 10 and then click Set Key.
- 2 Click Select Pivot and choose the pivot on the end of the toe.

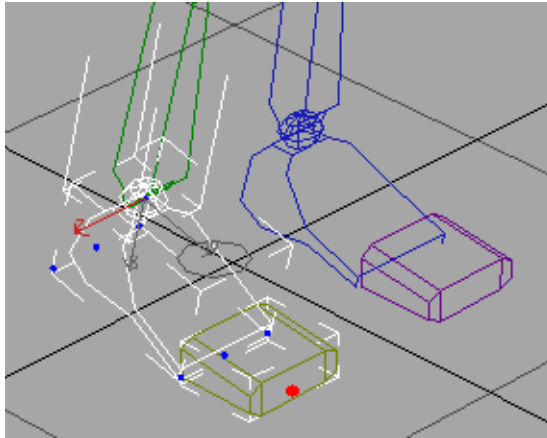

- 3  Click Set Sliding Key to set a key for the pivot.
- 4 Click Select Pivot again, to turn it off.
- 5 In the Perspective viewport, right-click the foot and choose Rotate from the quad menu.
- 6 Rotate the right foot about -25 degrees around the Z axis so the heel continues to raise and roll off the toes.

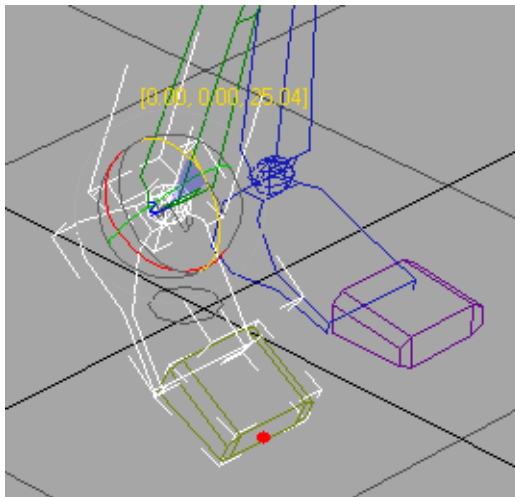

- 7  Click Set Sliding Key to keyframe the foot rotation.

The sliding key does not join to the previous key, but has IK Blend set to 1, which keeps the foot above the ground plane. If you had set a planted key, the foot would jump to a different location as it attempted to join to the previous key.

Lift the foot off the ground:

When the foot lifts off the ground completely, you'll set a free key.

- 1 Move the time slider to frame 15.
- 2 In the Left viewport, right-click the foot and choose Move from the quad menu. Move the foot up off the ground and forward.



By moving the foot, you are seeing an example of Biped's IK system. You are creating rotations for the upper and lower leg links as you move the foot.

- 3  On the Key Info rollout, click Set Free Key to keyframe the lifted position of the foot.
- 4 Move the time slider back and forth to observe the animation so far.

- 5 Save the scene as **MyWalk02.max**.

Lock down the opposite foot:

- 1 Move the time slider back to frame 0 and select *Bip01 L Foot*.

- 2  On the Key Info rollout, click Set Key.

- 3  Click Set Planted Key to set an initial key for the left foot at frame 0.

This key locks down the foot for any subsequent movement in upcoming frames. If you were to grab the center of mass and move it down, both legs would bend instead of moving below the ground plane.

- 4 Turn on Select Pivot and pick the pivot point at the ball of the foot.

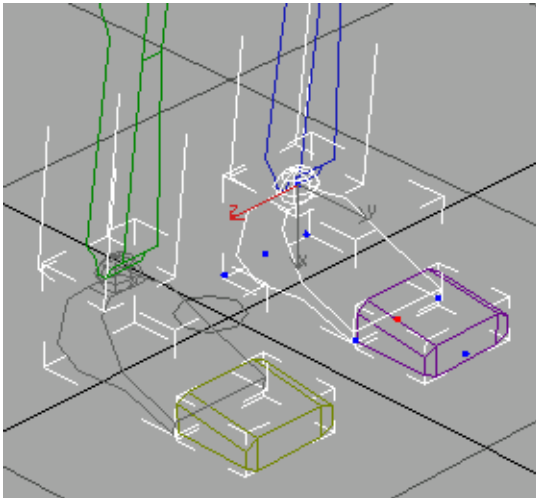

The left foot with a new pivot point.

- 5 Click Select Pivot to turn it off.

Keyframe the center of mass:

- 1  On the Track Selection rollout, click Body Horizontal.

Bip01 is automatically selected.

- 2  At frame 0, click Set Key for *Bip01*.
This creates a start key for the center of mass.
- 3 Move the time slider to frame 15.
- 4 In the Left viewport, use the Move Transform gizmo to move the center of mass so the torso shifts forward, and then set another key.



NOTE Because the center of mass is the root node, you can use only Set Key, not the specialized IK keys.

- 5 Use the Move Transform gizmo to move the center of mass down a little, so the left knee bends slightly, then set another key.
The left leg bends automatically as the center of mass moves down.

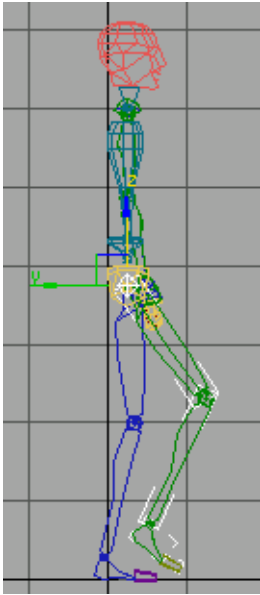

6 Select *Bip01 L Foot*.



7 On the Key Info rollout, set a planted key for the ball of the foot.

8 Right-click the left foot and choose Rotate from the quad menu. Rotate the foot so the heel is lifting up off the ground, and then set another planted key.

The heel is rotated off the ground.

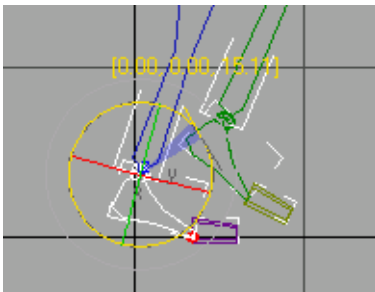

9 Move the time slider to frame 22 and click Set Key.

- 10 Right-click in the Perspective viewport, turn on Select Pivot, and then pick the pivot at the end of the toes of *Bip01 L Foot*.



- 11 On the Key Info rollout, click Set Sliding Key, then turn off Select Pivot.

- 12 In the Left viewport, rotate the left foot up a little more and set another sliding key.

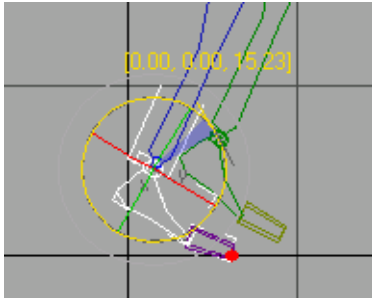

- 13 On the Track Selection rollout, click Body Horizontal. Move the center of mass forward again, and set a key.

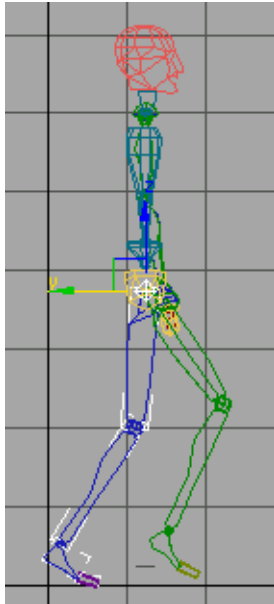

Keyframe the right heel hitting the ground:

- 1  At frame 22, select *Bip01 R Foot* and move it forward, then set a sliding key.

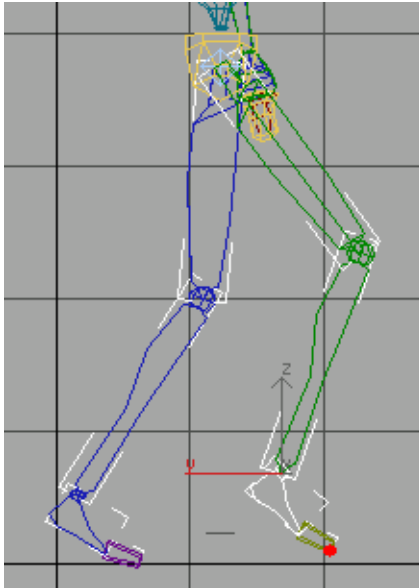

- 2 Activate Select And Rotate, note the location of the gizmo intersection, and then turn on Select Pivot (this deactivates Rotate). Pick the point at the ankle that lay at the gizmo intersection, and then set a sliding key.
- 3 Turn off Select Pivot. Rotate the foot so it's parallel to the ground, and then set a sliding key.

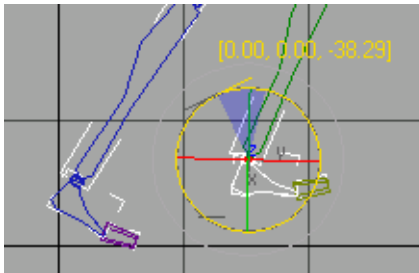

- 4 Turn on Select Pivot, and set the pivot to the heel. Set another sliding key.

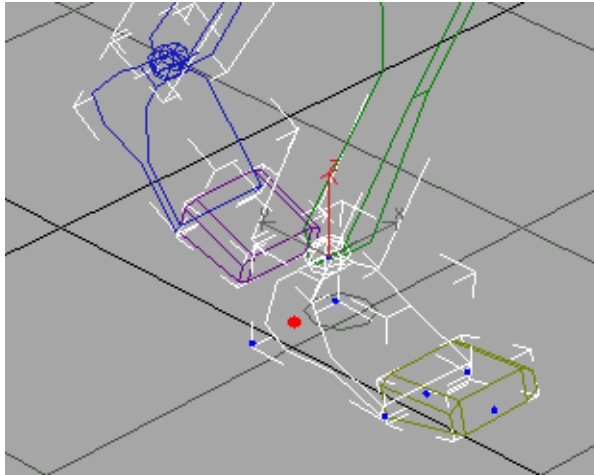

The pivot point moved to the heel.

- 5 Turn off Select Pivot. Move the time slider to frame 27.
- 6 In the Left viewport, move the right foot forward a little. Notice that the foot moves away from the pivot point in the viewport.

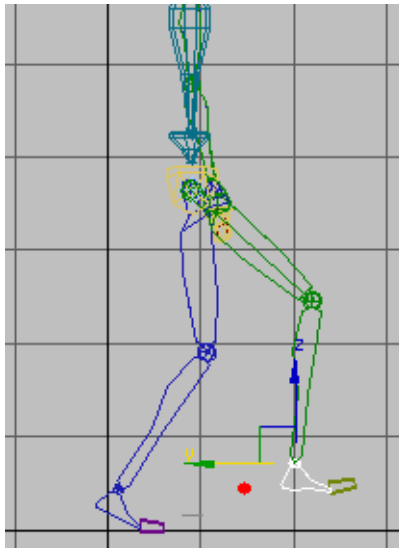

Sliding Key lets foot move away from pivot.

- 7  Set a sliding key.

The pivot point in the viewport moves to the heel of the foot.

- 8 Move the right foot down so it touches the ground, and set another sliding key.

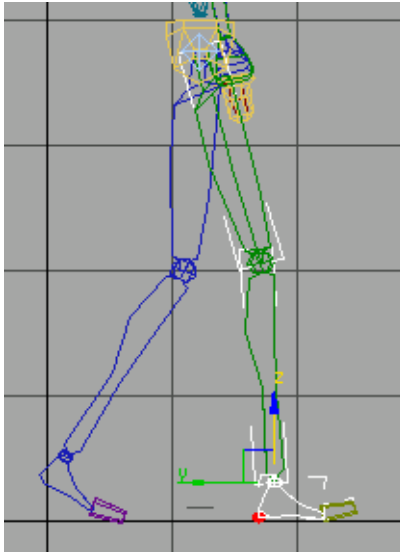

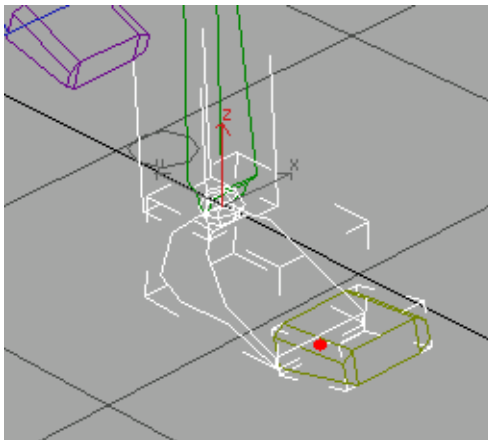

- 9 Turn on Select Pivot. Pick the pivot at the ball of the right foot.



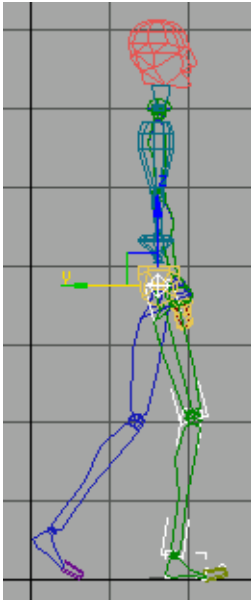

The pivot moved to the ball of the right foot.

- 10  Click Body Horizontal, move the center of mass so that it is over the heel of the right foot and set a key.



- 11  At frame 27, select *Bip01 L Foot* and set a free key.
- 12 Move the time slider and watch the animation of the foot and the pivot points.
- 13 Save the scene as **MyWalk03.max**.

Continue the walk cycle:

- 1  At frame 27, click Body Vertical so you can move the center of mass.
- 2  Lower the body slightly, so the biped sinks a bit as the right foot flattens onto the floor. Set a key for the center of mass.
- 3 Move the time slider ahead to frame 32. Move the center of mass so it's over the ball of the right foot. Set a key for the center of mass.



- 4  Move and rotate *Bip01 L Foot* so the heel swings above the ground. Set a free key.

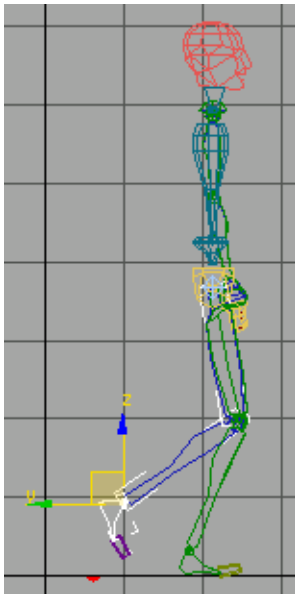

Use this procedure throughout this exercise: Lock one foot by setting planted or sliding keys, move the center of mass, then move the other foot and set a key.

Complete the walk cycle:

- 1  Move the time slider to frame 37 and click Body Horizontal. Move the center of mass forward and set a key.

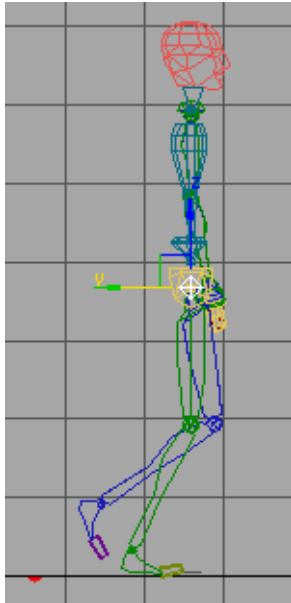



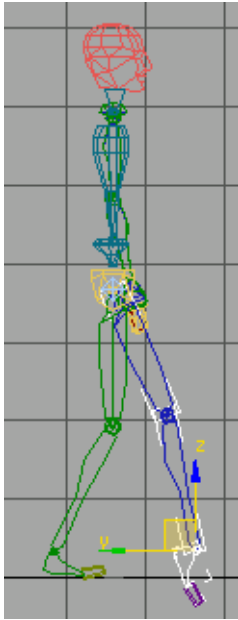

- 2  Select *Bip01 L Foot* and move it so the leg is extended in front of the biped. Set a free key.

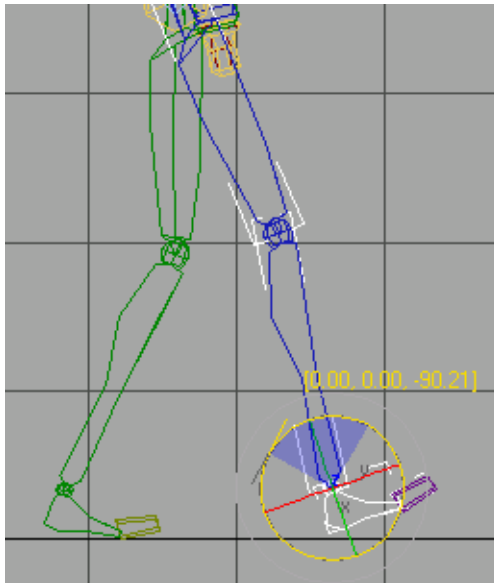

- 3 Rotate the left foot so the heel is down and the toes point upward. Set another free key.
Now the foot looks better.





- 4  With the left foot selected, click Select Pivot and select the pivot at the heel. Set a planted key for the pivot.
- 5 Turn off Select Pivot.
- 6 Move to frame 39, and rotate the left foot so it is flat on the ground.
- 7  Set a planted key for the left foot.
- 8  Click Body Horizontal and move the center of mass so the body moves forward.
- 9  Set a key for the center of mass.
- 10  At frame 41, rotate the left toes (*Bip01 L Toe0*) so they are flat on the ground. Set a planted key.
- 11 Select *Bip01 R Foot* and move the time slider back to frame 30. Set a planted key.

- 12 At frame 32, rotate the right toes so they are flat, and set another planted key.
- 13 Move the time slider to frame 37 and rotate the right foot up a little, then set a planted key.
- 14 Move the time slider and review the motion. Add rotations for the toes as needed.
- 15 Save the scene as **MyWalk04.max**.

Display trajectories:

Biped has its own trajectory display. You can use it to observe the movement of the center of mass in the walk cycle. You can also edit the keys on the trajectory directly in the viewport.

- 1  On the Track selection rollout, click Body Horizontal.
- 2  On the Key Info rollout, turn on Trajectories.
A line appears on the viewports showing the COM's trajectory: the path it moves along during the animation.
- 3 Scrub the time slider, and watch the biped center of mass moving along its trajectory.
- 4  Choose Select And Move on the main toolbar. At the top of the Motion panel, turn on Sub-Object and then click any key on the trajectory.

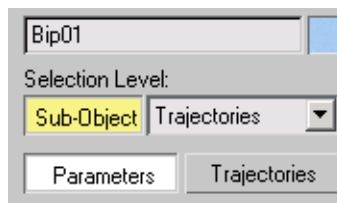

- 5 Use the Move Transform gizmo to move the keys to correct the trajectory.

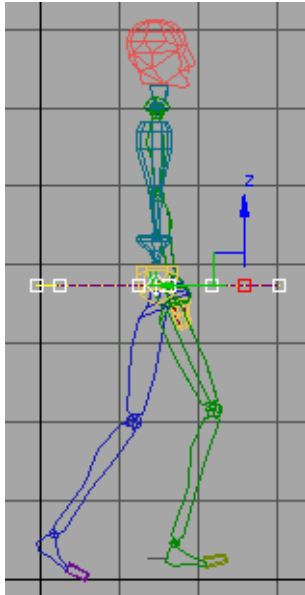

Edit keys in biped trajectory.

- 6 Turn off Sub-Object and Key Info rollout > Trajectories.

WARNING Don't use the standard Trajectories functionality (button near the top of the Motion panel) with Biped. Use the Trajectories button on the Biped rollout > Modes And Display expansion bar > Display group or the Key Info rollout.

Add arm swings:

The character is starting to look like it's walking, but it's still quite stiff. Adding arm swings will put some life in the animation.

The arms swing opposite to the legs. When the right leg is forward, the left arm is forward. Arms bend at the elbow on the forward swing, and stretch out straight on the backward swing.

- 1 Move the time slider to decide where to place the arm swings.
The right leg stretches out at frame 27, and you'll keyframe the left arm to swing there.

- 2 Auto Key Turn on Auto Key.

- 3 At frame 0, select and move the left hand slightly, to set a key.
- 4 At frame 0, select and move the right hand slightly, to set a key.
- 5 At frame 27, select and move the left hand so it swings forward. Position the arm so there is a slight bend at the elbow. Since Auto Key is on, you have keyframed the arm by moving it.



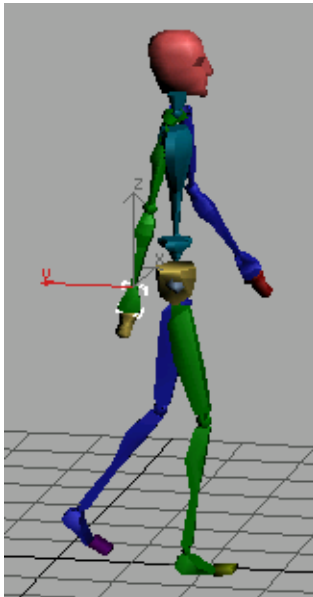

- 6 On the Track Selection rollout, click Opposite. The right hand is selected.
- 7 Move the right hand back slightly, so the arm is stretched out. The left arm is forward and bent a little, while the right arm is back and straight.



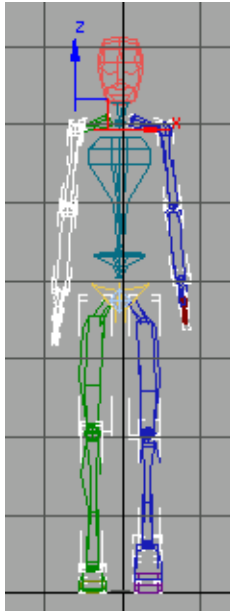

- 8 In the Front viewport, double-click *Bip01 R UpperArm*. The entire right arm is selected.



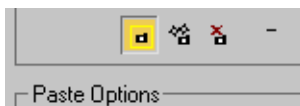

- 9  On the Motion panel, open the Copy/Paste rollout and click Copy Posture.
- 10  Click Create Collection. Name the Collection **walkcycle1**.
- 11 Turn on Create Snapshot from Viewport, just above the Paste Options group.

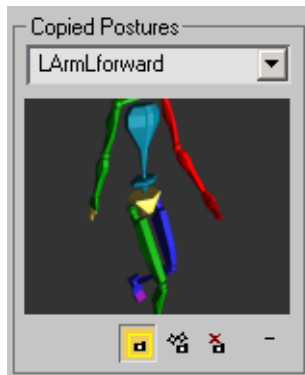

- 12  Click Copy Posture. Name the Copied Posture **RArm back**.
- 13  At frame 37, click Paste Posture Opposite.
The left arm swings behind the biped.
- 14 At frame 27, double-click *Bip01 L UpperArm*.
The entire left arm is selected.

- 15  On the Copy/Paste rollout, activate the Perspective viewport and click Copy Posture again. Name the posture **LArm forward**.



- 16  At frame 37, click Paste Posture Opposite.
The right arm swings in front of the body.
- 17 Turn off Auto Key.
- 18 Move the time slider back and forth to evaluate the animation.
- 19 Save the scene as **MyWalk05.max**.

Add sway to the shoulders and hips:

You've animated the character by moving its hands and feet and center of mass. But the spine, hips, and head are still stationary. You'll add some rotations to the shoulders and hips to complete the walk cycle.

- 1 Select *Bip01 Pelvis* and move the time slider to frame 15.
The left foot is locked at this frame with a planted key.
Be careful where you add the hip rotations. Don't inadvertently disturb the work you've done on the feet so far.
As the legs extend and swing forward, the hips rotate slightly in the direction of the movement.
- 2  Rotate the pelvis about the Y-axis approximately -2 degrees and set a key.

NOTE You can only rotate the pelvis about all three axes.

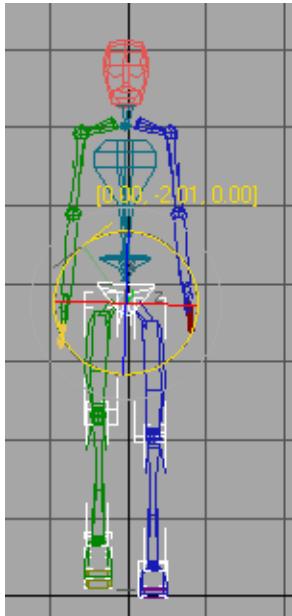

**Rotation added to the hips
from the Front view.**

The pelvis will not accept too much rotation. When you set the key, the pelvis corrects itself to account for the locked foot.

- 3  Move the time slider back to frame 0. Rotate the pelvis back 2 degrees about the Y axis and set a key. Rotate the pelvis back about -3 degrees about the X axis and set a key.

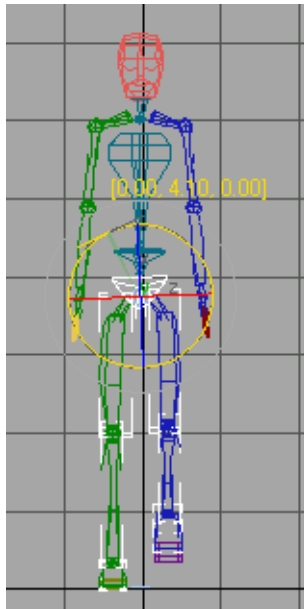

- 4 Move the time slider to frame 32. Rotate the pelvis about 4 degrees around the Y axis, then set a key. Repeat for the X axis and set a key
- 5 Move to frame 39 and rotate the pelvis -2 degrees around the Y axis again, then set a key.
The procedure is the same for the spine. At frame 27, the arms swing out in one direction. At frame 37, they swing in the opposite direction.
- 6 Select the biped spine object, Bip01 Spine.
- 7 At frame 27, rotate the spine in the direction of the arm swing and set a key. It should be about -6 degrees around the X axis.

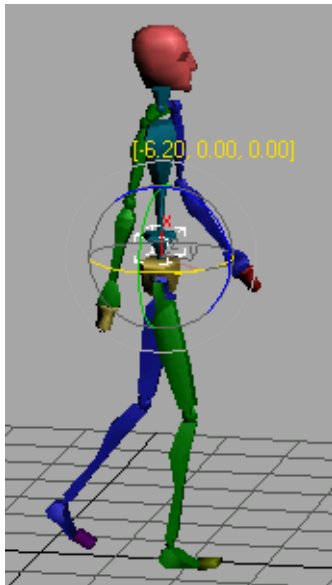

- 8 At frame 37, rotate the spine approximately 12 degrees about the X axis and set a key.

The spine can freely rotate about all three axes. You can make adjustments on each one. Rotate about the Z axis for a more stooped walk. Increase rotation about the X axis to make the walk loose and floppy.

Instead of animating the spine, you can also animate the clavicles to raise or lower the shoulders.

Twist links mode:

The Bend Links rollout includes tools you can use for animation. You can use either the Bend Links or the Twist Links to animate the bending and/or twisting of the spine.

- 1 Choose Figure Mode.
In the Structure Rollout change Spine Links to 5. You can have up to 10 spine links but you will use five to observe the effect.
- 2 Turn off Figure Mode.
- 3 Turn on Auto Key.

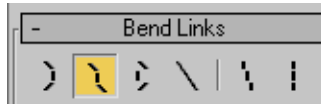

- 4 On the Bend Links rollout turn on Twist Links Mode.
- 5 Select the *Bip01 Spine* object. This is the lowest spine object in the biped.
- 6 Go to frame 0 and rotate the object slightly about the X axis to add a key. Do the same about the Y axis.
- 7 Move the time slider to frame 27 and rotate approximately 10 degrees about the X axis so the spine rotates following the swing of the arms. The blue arm is swinging forward, so rotate the spine to match.
- 8 You can also rotate -1 degree about the Y axis.
The slight rotation of the first spine object results in a larger effect further up the hierarchy.
- 9 Repeat at frame 37 in the opposite direction to match the swinging of the green arm outward.
- 10 Save the scene as **MyWalk06.max**.

You have animated a simple walk cycle using freeform animation and IK constraints.

You can use the footstep method of animation to create a walk cycle automatically. To learn about this technique, see [Creating a Distinctive Walk](#) on page 709.

Using Controllers with Biped

You can add controllers on top of Biped animations to create a wide variety of effects. You can use scale controllers to create stretchy legs or arms for cartoon animation, or create the illusion of breathing by adding a scale controller on the spine objects in the chest. You can add noise rotation controllers to the spine to make a biped shake while he walks, or to create twitching or random motion in the limbs or head.

Controllers can be added in the Motion panel, Assign Controllers rollout, or by using the Workbench.

Although this lesson is performed with footsteps, it could have been accomplished just as easily with a freeform animation.

Create stretchy legs with controllers:

In this exercise, you will add a scale controller to a biped's legs to stretch them during a portion of an animation.

1 Open *stretchyleg_start.max*.

2 Play the animation.

The biped walks for 10 paces, zooms to a lower level, and then walks another five steps. You'll add the scale controller, then animate the biped so that its legs stretch during the period of the downward leap.

3 Move the time slider to frame 162, then select the *Bip01 L Thigh* object, the blue leg.

4 On the Motion panel, open the Assign Controller rollout.

5 In the controller list window, expand the Biped SubAnim entry.

Now you can see the three list controllers.

6  Click the plus sign (+) next to *BipScaleList* to expand this controller. Select the entry marked *Available*, then click the Assign Controller button. The Assign Scale Controller dialog appears.

7 Choose Scale XYZ from the list, and click OK to close the dialog.

8  On the 3ds Max main toolbar, click the Select And Scale button. The Scale gizmo is visible on the thigh in the viewport.

9  Turn on Auto Key.

First, you will set a key to start the stretch. You don't want the stretch to start before frame 162. You want the biped to have a normal leg (unstretched) from the start of the animation up to this frame.

10 Using the Scale gizmo, stretch the leg *very* slightly in the X-axis at this frame, so the final value in the Coordinate rollout is 100 (no stretch).

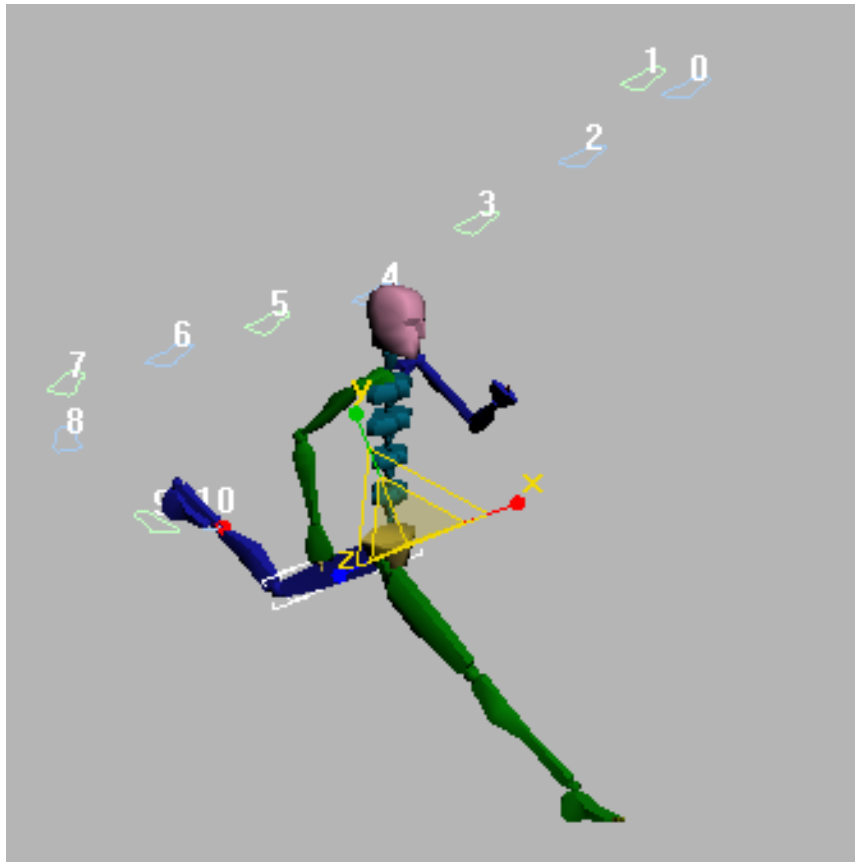

The leg at frame 162 (no stretch).

- 11 Move to frame 164, and stretch the leg so the foot reaches the footstep.

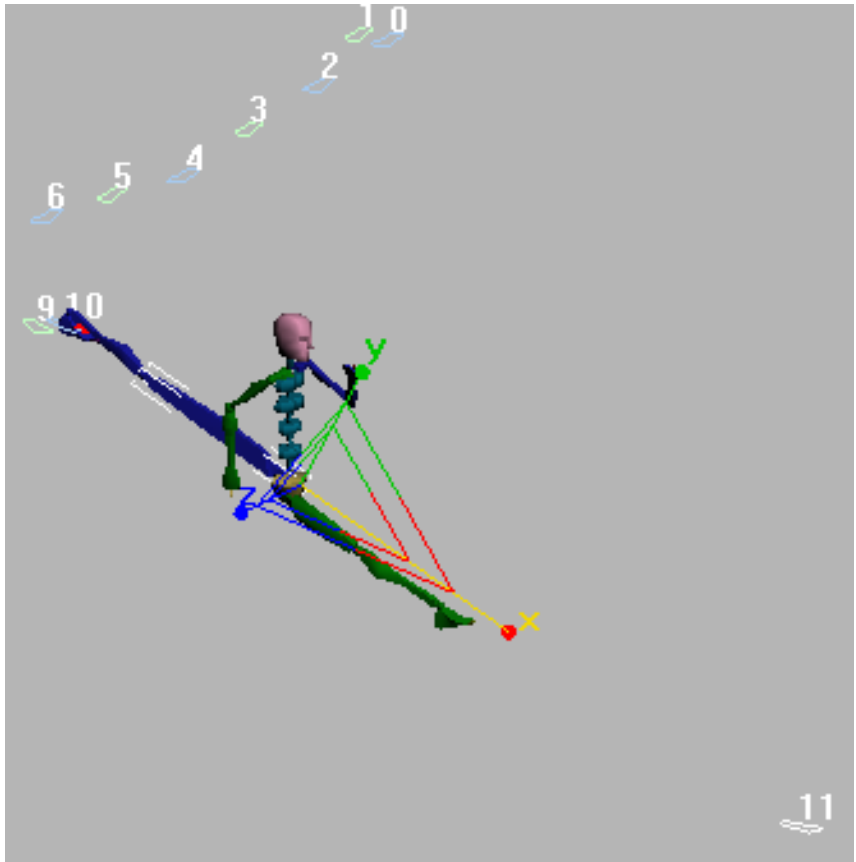

- 12 Move to frame 167, and again stretch the leg in the X-axis, so the foot stays on the footstep gizmo.

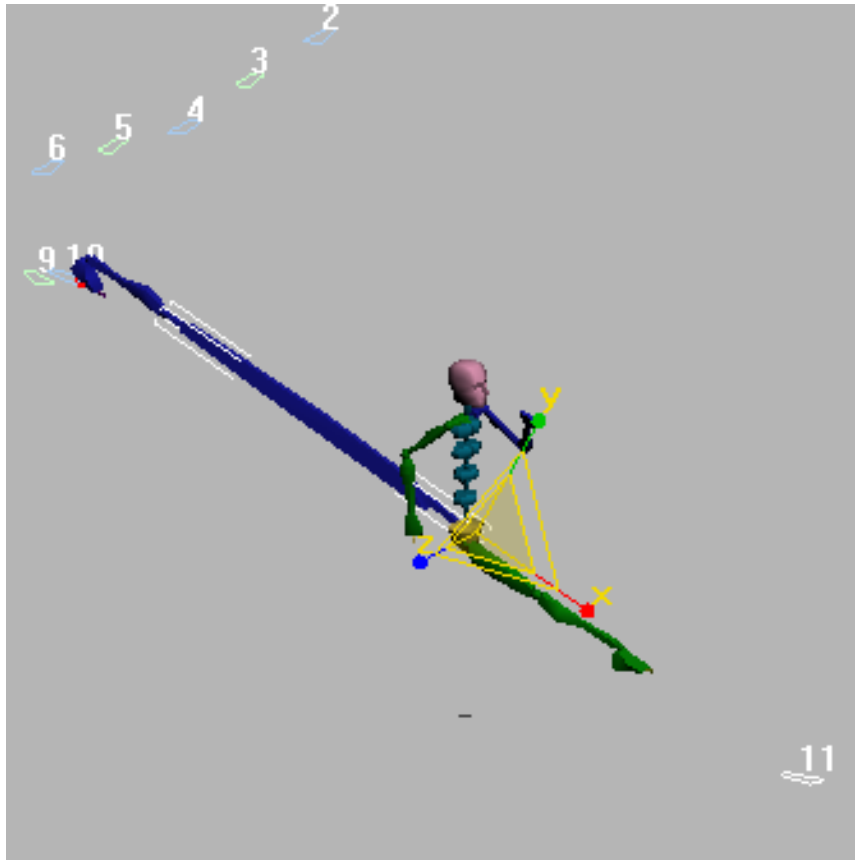

Leg stretch at frame 167.

- 13 Move to frame 169. Here, you begin to shorten the leg stretch.

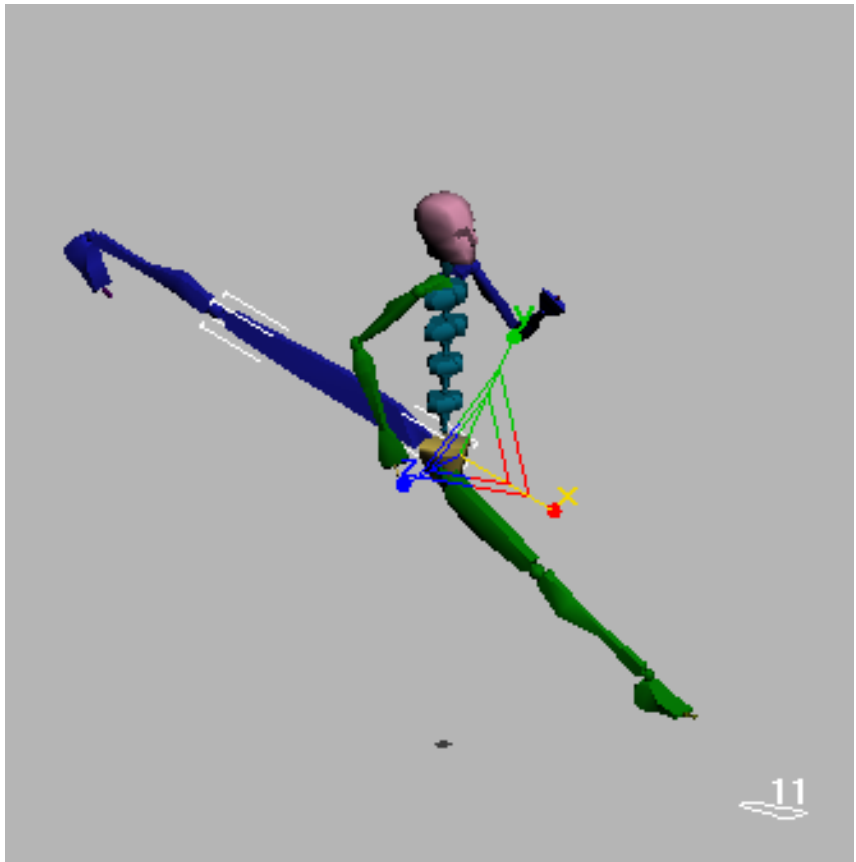

Leg shortens at frame 169.

- 14 Move to frame 181 and stretch the leg back to normal. Adjust it visually until the leg looks correct.

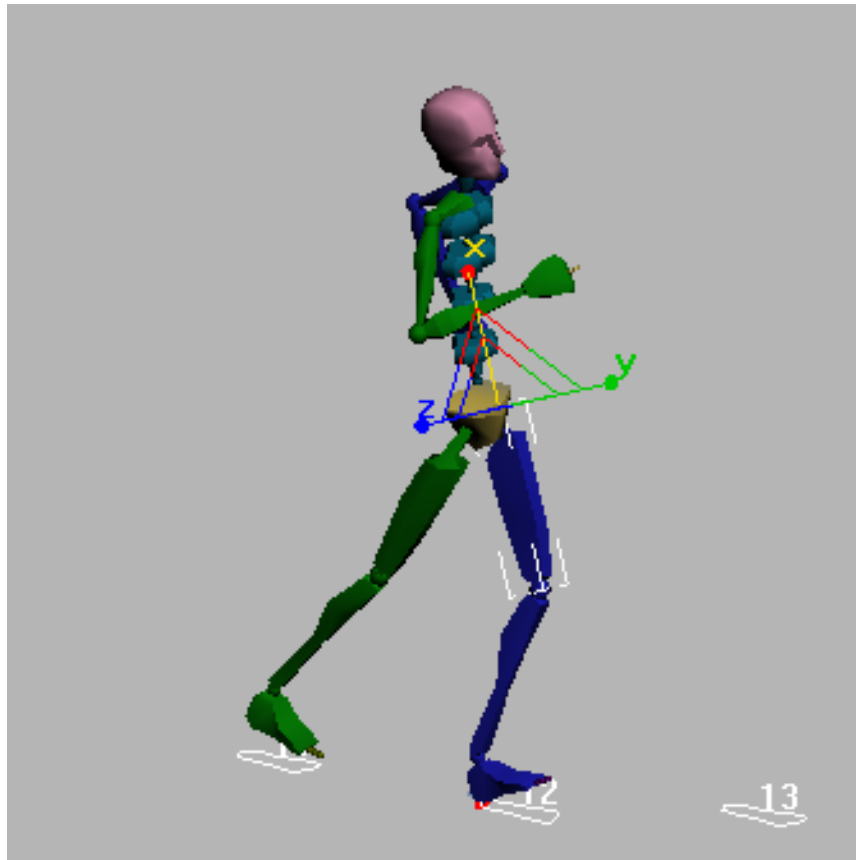

Leg at frame 181 appears normal.

- 15 Play the animation. The biped's back foot stays on the footstep and the leg stretches out as the biped descends to the lower set of footsteps.
For extra credit, add a scale controller to the green thigh, and stretch that leg out, roughly between frames 161 and 171.
- 16 Save your work as **mystretchy_leg.max**, or open *stretchyleg_final.max* for comparison.

Once you have controllers added to the biped body parts you can animate their parameters, or animate their weights. Here's an example that shows animation of parameters.

Animate the weights of SubAnim controllers:

- 1 Open *shake_and_walk_start.max*.
- 2 Play the animation.
The biped takes a few steps, then pauses for a moment or two, then walks on.
- 3 In the Perspective Viewport, select *Bip01 Spine*, the lowest spine object.

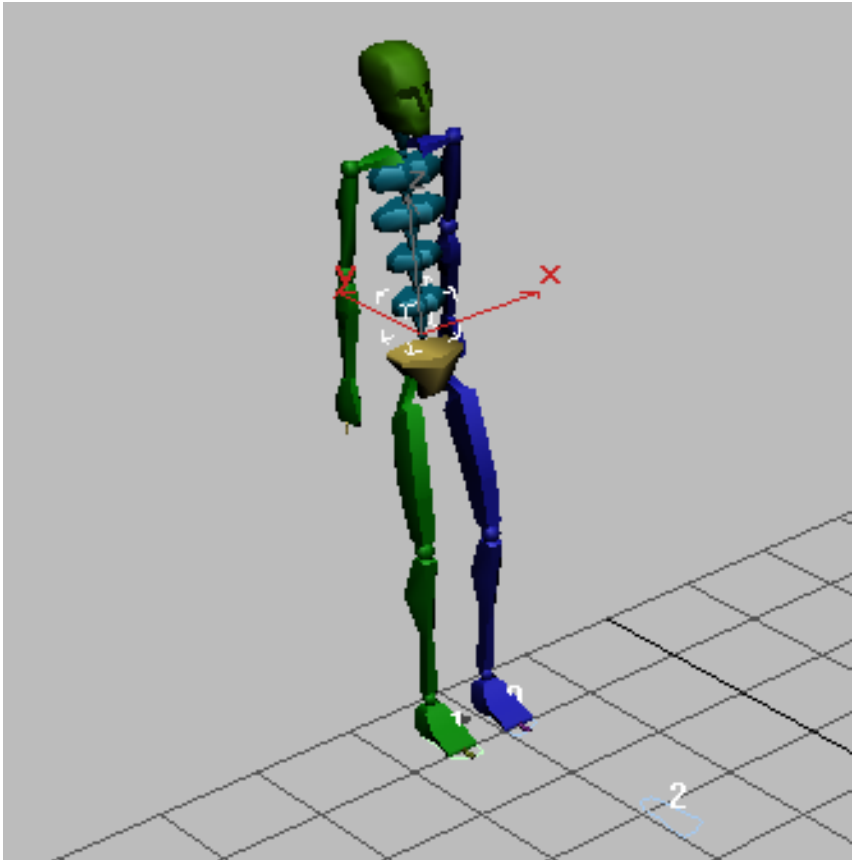

- 4 On the Motion panel, open the Assign Controller rollout.
- 5 In the Assign Controller window, expand the Biped SubAnim so you can see the list controllers.
- 6 Expand the *BipRotationList*, and highlight the entry marked *Available*.

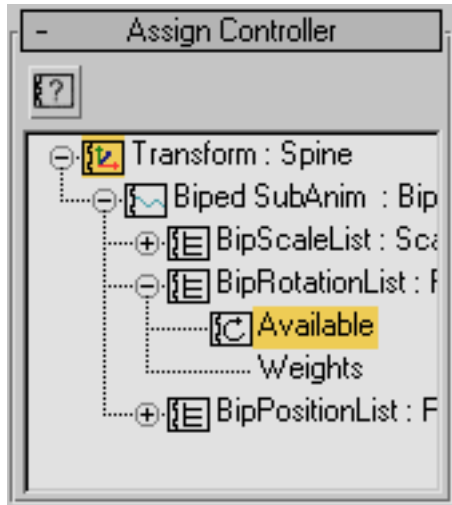

- 7 Click the Assign Controller button.
The Assign Rotation Controller dialog appears.
- 8 Choose *Noise Rotation* in the list, and click OK.
The Noise Rotation Properties dialog is displayed. Don't close this dialog.
- 9 Play the animation in the viewport.
The biped shakes drastically as it walks.
- 10 In the Properties floater, turn Fractal Noise off.
- 11 As the animation plays, change the Frequency in the Properties dialog, using the spinner. Lower the value until the shake becomes slower and more rhythmic. Probably a value of **0.2** or less will be good to use, but you can choose whatever you like.
- 12 As the animation plays, change the X, Y and Z values. Set the three values to **0**, then change them individually, one at a time.
To create a shimmy effect, set X Strength to be **2**, Y and Z Strength to **0**.

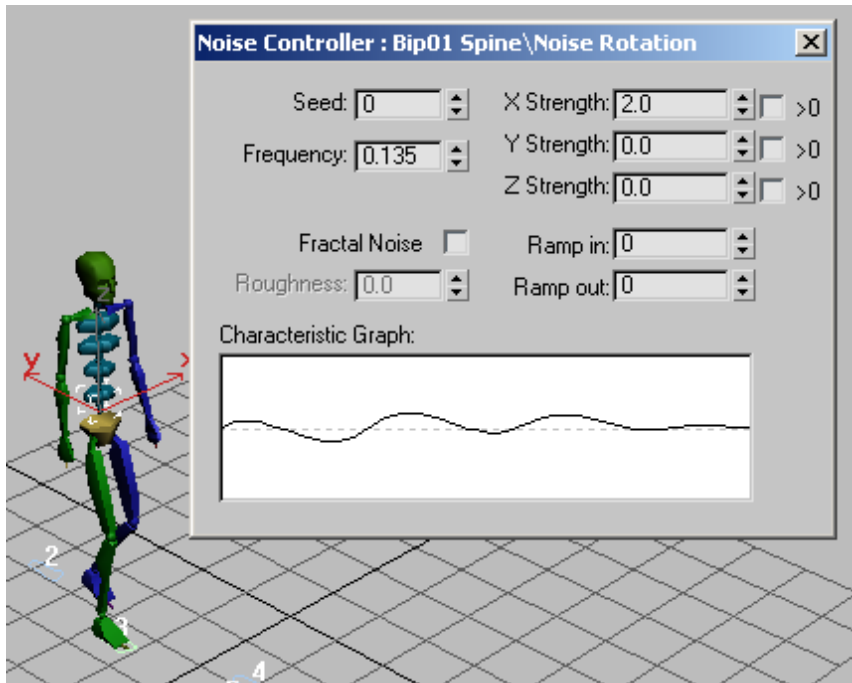

13 Close the Noise Rotation Properties dialog.

In this example, the biped should shake only while walking. The frames from 69 through 191 should not have any shaking. To complete this effect, you will animate the weight of the noise controller.

Animate the weight of the noise controller:

- 1 On the Motion panel, expand the Weight entry of the Noise Rotation controller you added to the spine object. Highlight *Weight 0*.

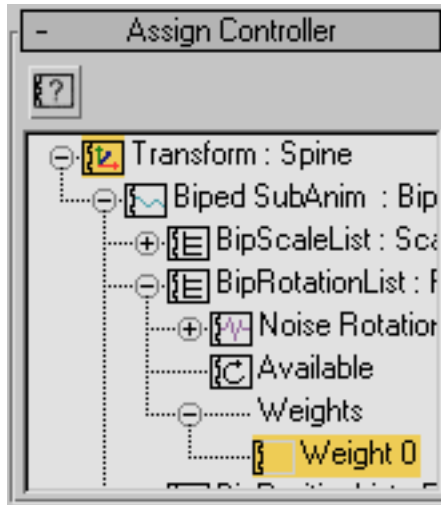

There is a trick to accessing the weights.



- 2  Open the Keyframing Tools rollout and click the Manipulate SubAnims button.

The Motion panel now displays additional rollouts for Position List, Scale List, and Rotation List.

- 3 Scroll to the Rotation List and select the Layer->Noise Rotation.

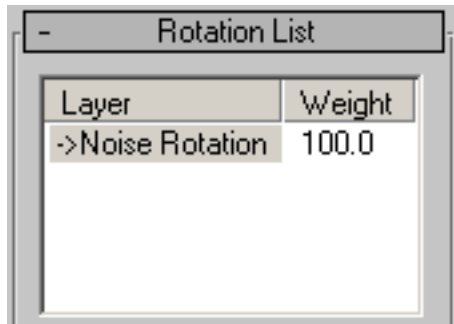

Now you're ready to animate the Weight field.

- 4  Turn on Auto Key
- 5 Move the time slider to frame 70.

- 6 Near the bottom of the Rotation List rollout, right-click the Weight field spinner. This sets it to zero.

TIP Right-clicking any spinner resets it to its lowest possible value.



- 7 Move the time slider to frame 69.

TIP Use the < and > keys on the keyboard to move from frame to frame.

- 8 Change the Rotation List Weight field to **100.0**.
The spinner is outlined in red to show it is animated.
- 9 Drag the time slider back and forth from frame 0 to frame 100 to see the animation. The biped shakes while walking and stops shaking during the pause.
- 10 Next, you make the biped start shaking again at frame 191. At frame 190, set a key with the Noise Rotation Weight set to **0**, and to **100** at frame 191.

TIP At frame 190, hold down the Shift key while you right-click on the spinner. This will set a key without having to change the value.

- 11 In the Keyframing rollout, turn off Manipulate SubAnims when you're done.
- 12 Play the animation.
- 13 Save your file as **myshake_and_walk.max**, or open *shake_and_walk_finished.max* for comparison.

If you are exporting to a game engine, or if you want to use this animation with Layers or in the Motion Mixer, you will need to collapse the list controller animation (see following procedure). This will add the controller's animation keys to the tracks of the Biped SubAnim.

NOTE 3ds Max has different behaviors for controllers and constraints. The controller animation will be *layered* onto the existing keys in the Biped SubAnim track. If you have used a constraint, however, it will *replace* the Biped SubAnim tracks.

Collapse the list controller track:

- 1 Continue from before, or open *shake_and_walk_finished.max*.
- 2 If you open the file, select the *Bip01 Spine* object in the viewport, open the Motion panel, and expand the Assign Controller rollout.
- 3 In the Assign Controller window, highlight Biped SubAnim and then right-click.
- 4 Choose Properties from the right-click menu.

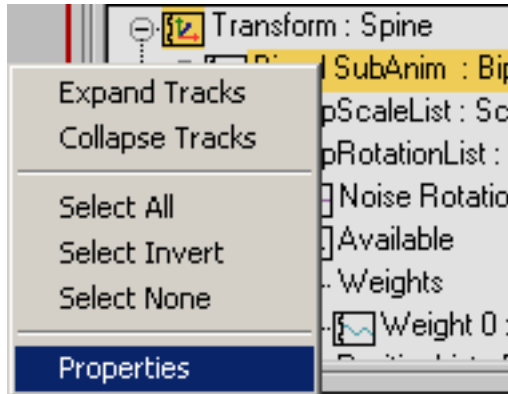

The SubAnim Property dialog appears.

- 5 In the Enable options, turn off Position List and Scale List, so the Rotation List is the only one active.
- 6 In the Collapse options, turn off Position, and turn on Rotation List, Don't Delete, and Per Frame.

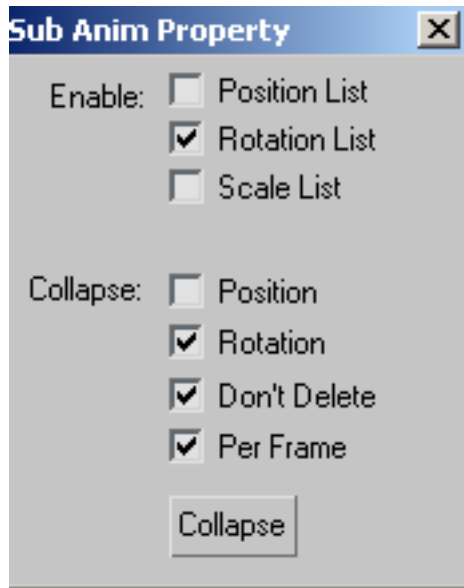

- 7 To collapse the rotation track, click the Collapse button at the bottom of the SubAnim Property dialog.
Wait while the calculations take place.
When the collapse is completed, the dialog closes and the track bar fills with keyframes.

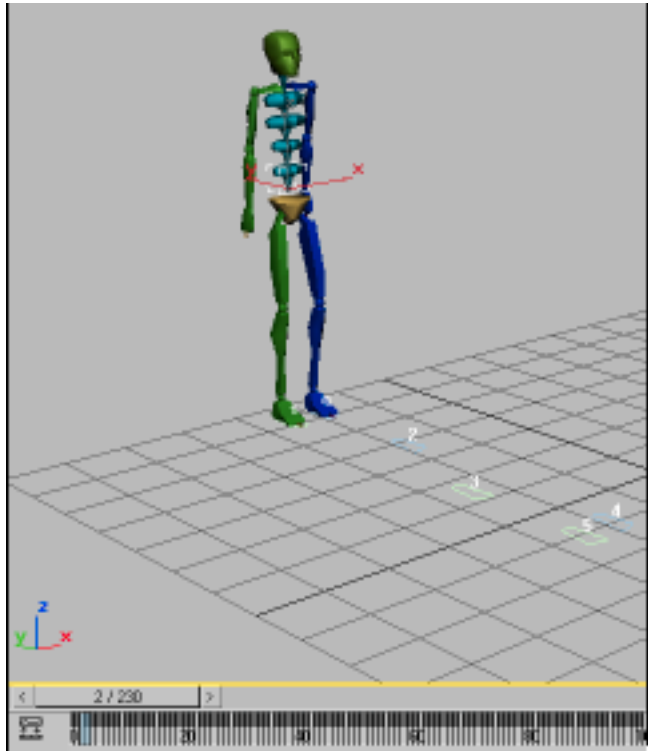

- 8 Save your work as **mycollapsed_shaking.max**, or open *shake_and_walk_collapsed.max* for comparison.

You can use the Workbench to reduce the keys that you've created.

Creating Animated Bones with Biped

You can take the animated biped skeleton and use it to generate a 3ds Max bone structure that follows the same animation, by using the File Export and Import capabilities. In just a few steps, you will be able to take your biped animation and use it without the biped attached.

Create animated bones from bipeds:

- 1  On the Quick Access toolbar, click the Open File button, navigate to the `\animation\character_animation\freeform_animation` folder, and open `createbones_start.max`.

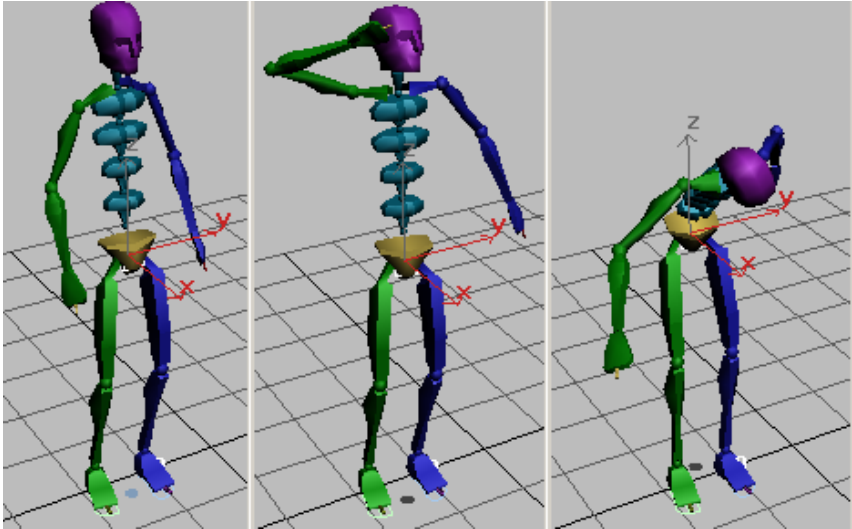

Biped takes a bow.

- 2 Play the animation.
Observe the biped and its movement.



- 3 From the Application menu, choose Export.
- 4 Name the file **mycreatebones.fbx**. From the Save As Type list, choose Autodesk (*.FBX), and then click Save.
This opens the Export FBX dialog.
- 5 Accept all the default values and click OK.
Wait while the exporter calculates the TRS animation.



- 6 From the Application menu choose Reset.
The biped disappears and the viewports reset.



- 7 From the Application menu, choose Import and open the file you just exported.
The import dialog appears.
- 8 In the Import Configuration group, click the More button next to Bones. Use the Advanced Bone Options dialog that opens to set the Bone Objects > Width and Length both to **3**.
- 9 Click OK to close the dialog. Click OK again to import the FBX file and create the bones.
A bone skeleton appears in the viewport.

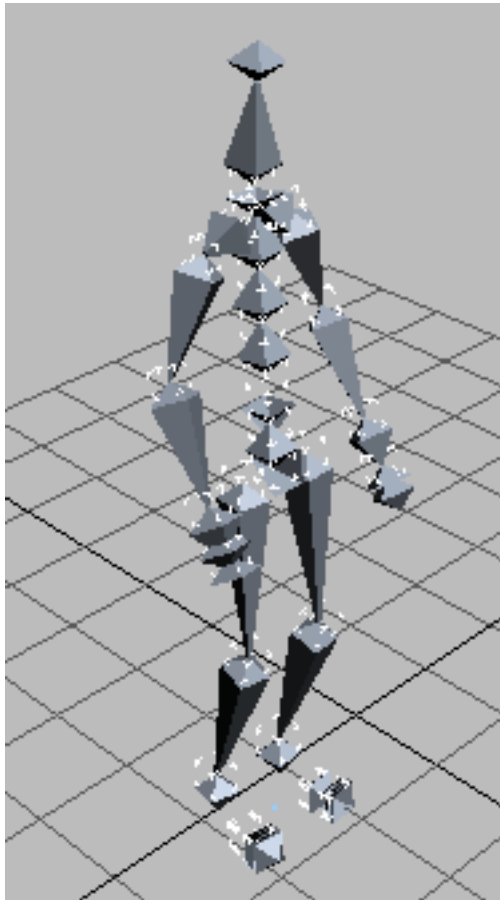

- 10 Play the animation.
The skeleton has the identical animation as the original biped.

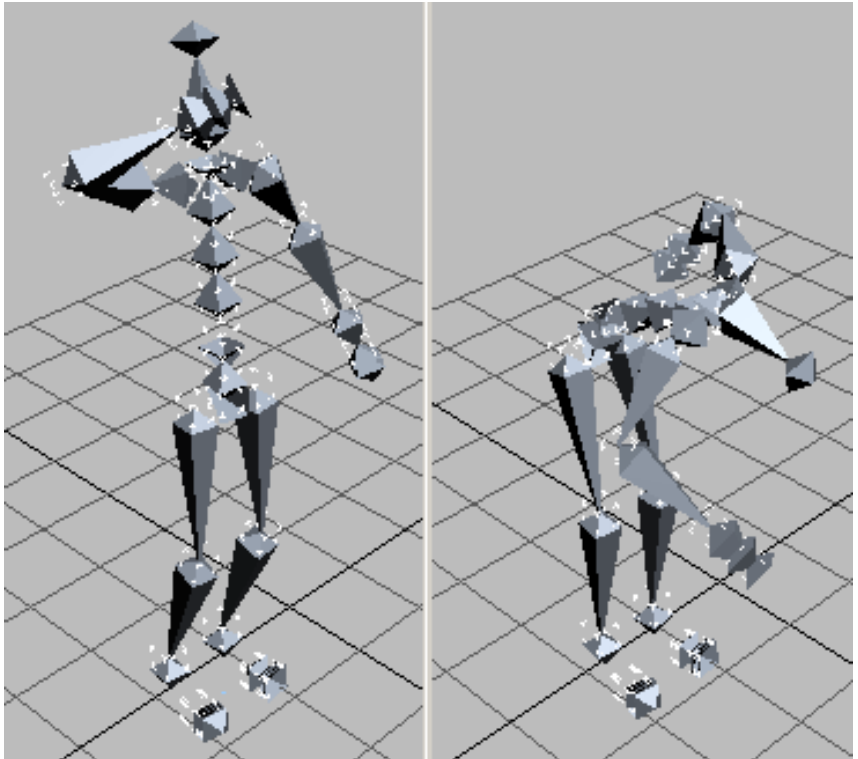

11 Save your file as **mycreatebones.max** or open *createbones_final.max* for comparison.

Summary

This tutorial showed you a variety of ways to animate a Biped without using Footsteps mode. In addition, it showed how you can apply a Biped animation to a skeleton made from 3ds Max Bones.

Using Motion Flow

Motion Flow mode lets you combine *clips* (.*bip* files) to create longer character animations. The BIP files are joined using velocity-interpolated or minimum foot sliding transitions for a seamless transition between the source and destination clip.

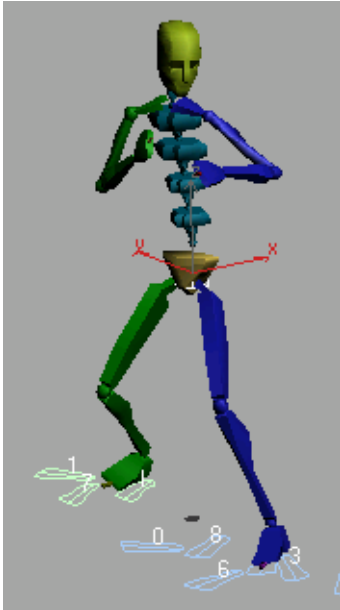

In this tutorial, you will learn how to:

- Combine two motion capture BIP files and unify the result.
- Create a Shared Motion Flow so you can use one motion flow graph to animate multiple bipeds.
- Use Create Random Motion to create random scripts for multiple bipeds, so you can animate a crowd.
- Use Create Random Motion to create a random script for one biped.

Skill level: Intermediate

Time to complete: 1.5 to 2 hours

Adding Clips to the Motion Flow Graph

In this tutorial, you'll become familiar with the Motion Flow Graph and how to add clips, *.bip* files, that will control your bipeds.

Create a biped:

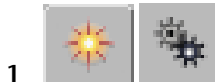

- 1 On the Create panel, click Systems.
- 2 On the Object Type rollout, click Biped.
The Biped button turns gold.
- 3 In the Perspective viewport, click and drag up, starting at approximately 0,0,0.
A biped appears in the viewports.

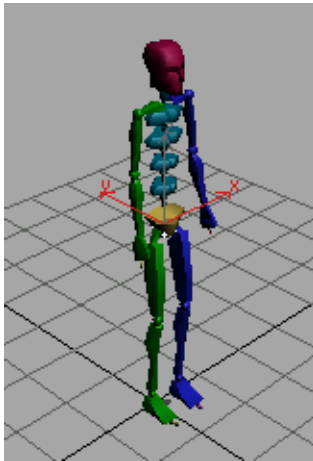

Default biped

- 4 Right-click in the viewport to turn off the Biped button.

Add clips to the Motion Flow graph:



- 1 Select any part of the biped and open the Motion panel.



- 2 On the Biped rollout, turn on Motion Flow Mode.
The Motion Flow rollout displays.

- 3  On the Motion Flow rollout, click Show Graph.

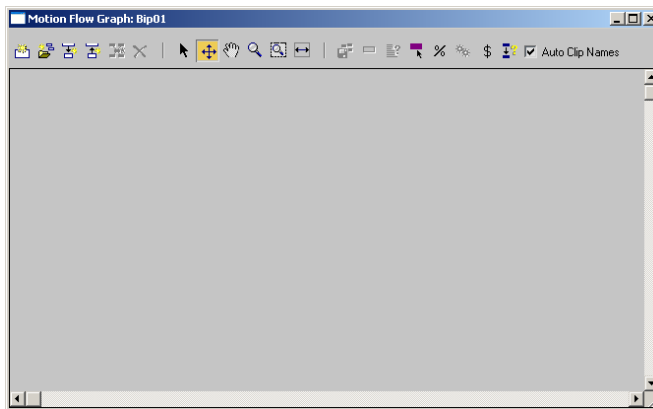

Motion Flow Graph

- 4  On the Motion Flow Graph toolbar, click Create Multiple Clips. The Open dialog displays so you can specify the location of your motion files.
- 5 Hold down the Ctrl key and click both *AxeKick.bip* and *BackKick.bip*. These files are both in the folder `\sceneassets\animations\`.
- 6 Click Open. The two motion files appear in the Motion Flow Graph window.

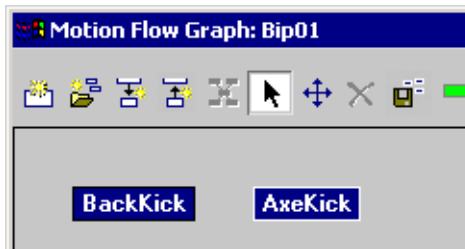



- 7 Save the scene as **MyMoFlow01.max**.



Creating and Using Motion Flow Scripts

The Motion Flow Graph stores *.bip* files, referred to as *clips*. To create a script, you select clips that you have added to the Motion Flow Graph.

Set up the lesson:

-  1 Continue from the previous lesson or open the file *cs4_tut_moflow01.max*. This scene is in the folder `\animation\character_animation\motion_flow\`.
-  2 If you are using *cs4_tut_moflow01.max*, select any part of the biped and open the Motion panel.
-  3 Click Show Graph to make sure that the Motion Flow Graph is displayed.

Create a script:

-  1 On the Motion Flow rollout, in the Scripts group, click Define Script.
-  2 On the Motion Flow Graph, click the *AxeKick* icon first, and then the *BackKick* icon.

The clip names appear in the list in the Scripts group. The name *script1* displays in the text field above the list. In the Motion Flow Graph, a red transition line joins the two clips, showing that they are included in the current script. By default, Biped uses “Minimum Motion Loss” to find a likely starting frame for the transition between the source and destination clips. You have created a script called *script1*.

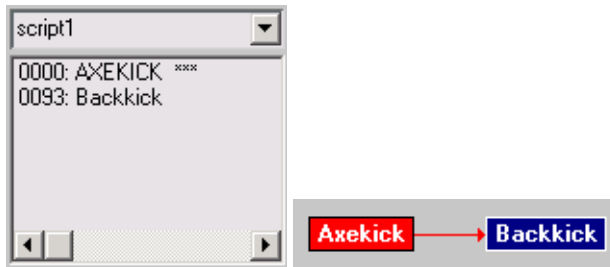

- 3  Close the Motion Flow Graph window and click Play.



Use Orbit and Zoom to adjust the Perspective view for a better look at the motion.

As the animation progresses, the script list shows the name of the currently played clip in uppercase letters followed by three asterisks. The numbers to the left of each clip name show the frame number where the clip begins.

The default Minimum Motion Loss search method did not choose ideal starting frames in this case: the biped spins unnaturally during the transition. First you'll edit the transition manually, then you'll try an optimized transition that uses minimum foot sliding.

Use the Transition Editor:

When you edit transitions manually, you can discard unwanted motion and adjust the duration of transitions. You can also change the direction of the destination clip in the Transition Editor.

- 1 Click *AxeKick* in the Scripts list.
Controls in the Scripts group are activated.



- 2  Click Edit Transition.

The Transition Editor dialog displays; the source and destination clip names appear in the title of the dialog. Position the dialog so the Perspective viewport is visible.

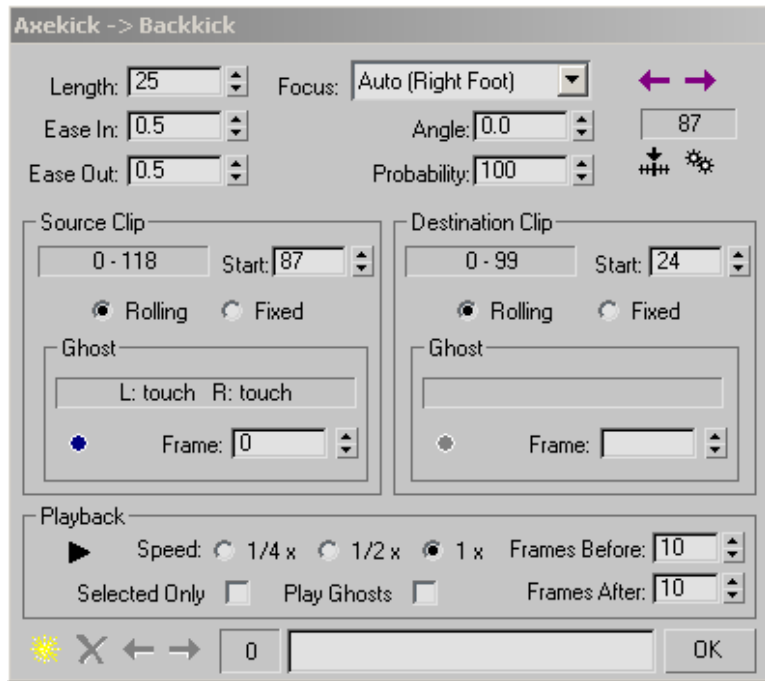

- 3  Click Go To Start Frame near the upper right of the Transition Editor.

The time slider is positioned at the first frame of the transition. By default, the duration of the transition is 25 frames. This is displayed in the Length field on the upper left of the Transition Editor.

Red and yellow stick figures (called “ghosts”) in the viewports help to establish a starting frame for both clips. Both stick figures display during the period of transition. Red represents the destination clip motion. The biped interpolates between the yellow and red ghosts over the course of the transition.

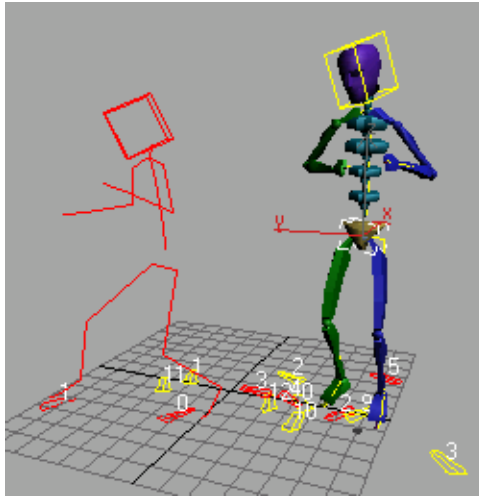

- 4 In the dialog, set Angle to **-50.0**.
The destination ghost changes orientation.

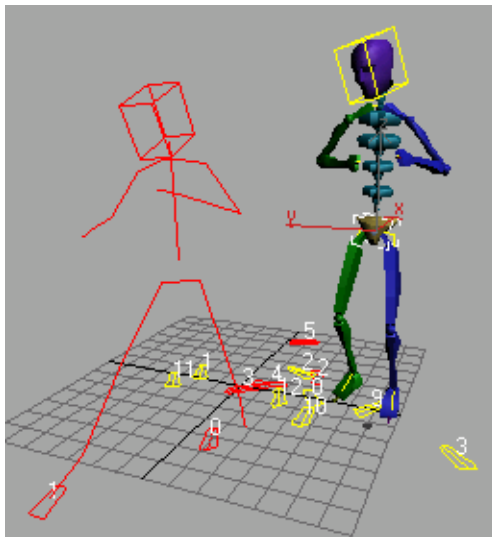

- 5 In the Destination Clip group, set the Start to **0**.
You can choose the destination starting frame by viewing all of the clip's motion.

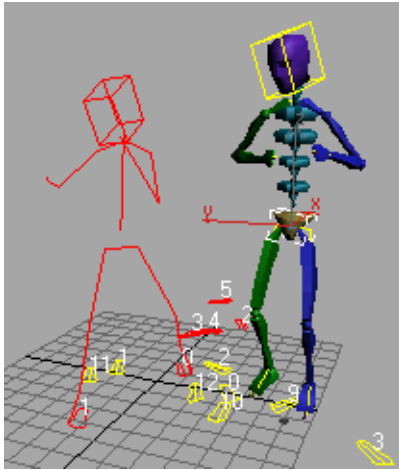

- 6 Drag the time slider back and forth over the transition.
In order to create a smooth transition, you'll look for areas in the source and destination clips where foot and body movements will flow together cleanly. Frame 80, where the character's right foot is in the air, looks like a reasonable starting frame for the source clip. Body weight is in the process of shifting to the right foot.
- 7 In the Source Clip group, set the Start to **80**.
- 8 Move the Frame spinner in the Destination Clip > Ghost group, and watch the red stick figure that represents the destination clip. At frame 20, the character is starting to push backward with its right foot. The character's weight will be on the right foot in both clips if this frame is used as the Destination Start Frame.

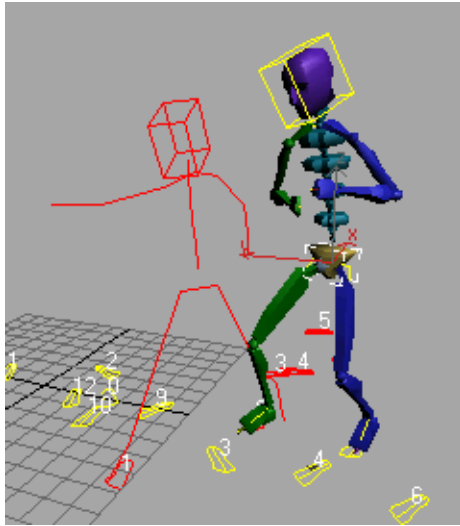

- 9 In the Destination Clip > Ghost group, click Set Start Frame. The Frame value (20) is copied to the Destination Clip > Start Frame field. Biped recalculates and repositions the destination clip.
- 10 Near the top of the dialog, set Length to 6 frames.
- 11 Play the animation.
The weight shifts to the right foot in both clips during the transition.
The transition now looks natural.
Next, you'll try an optimized transition.



- 12 In the Transition Editor dialog, click Optimize Transition.
The Transition Optimization dialog displays.
- 13 On the Transition Optimization dialog, choose Search Near Existing Transition. Click OK.
- 14 Play the animation.
The transition calculated by the automatic optimization also looks good.
Optimized transitions are a time saver if you have to process many clips and transitions.

TIP You can select multiple transitions in the Motion Flow Graph window and use Optimize Selected Transitions in the Motion Flow Graph toolbar to optimize all the transitions at once. Optimized transitions can take time to compute, but the results are worth the extra processing time.

Make the animation available outside of Motion Flow mode:

To make the animation available in your scene outside Motion Flow mode, use the Create Unified Motion command.

- 1 Click OK to close the Transition Editor.



- 2 Make sure the Define Script button in the Motion Flow rollout > Scripts group is turned off.



- 3 On the Motion Flow rollout, in the Scripts group, click Create Unified Motion.

The Unify Options dialog displays.

- 4 Click OK to accept the default settings on the Unify Options dialog.



- 5 On the Biped rollout, turn off the Motion Flow Mode button.
Now the motion is available as a freeform animation in your scene.

Open *cs4_tut_moflow02.max* to see the animation. Note that a unified motion does not contain footsteps.

Looping Animation in Motion Flow Mode

By creating a script that repeatedly calls the same motion clip, you can create a loop cycle that lengthens the motion. This is a good way to lengthen a walk or run cycle. You will use layers to change the looped animation.

Set up the lesson:

- 1 Reset 3ds Max.

2 In the Perspective viewport, create a biped starting at approximately 0,0,0.



3 Open the Motion panel.



4 Turn on Motion Flow Mode.



5 On the Motion Flow rollout, click Show Graph.

The Motion Flow Graph displays.



6 On the Motion Flow Graph toolbar, click Create Multiple Clips.

The Open dialog displays.

7 Open *walk2loop.bip*. This file is in the folder `\sceneassets\animations\`.

The motion clip appears in the Motion Flow Graph window.



8 On the Motion Flow Graph toolbar, click Create All Transitions.

A Biped dialog asks if you want to create transitions from each clip to itself. Click Yes.

A transition is created pointing back at the selected clip.



NOTE When using Create All Transitions with multiple clips, you must first select all the clips for which you want transitions created.



9 On the Motion Flow Graph toolbar, turn on Select Clip/Transition, if necessary.

10 Select the transition arrow in the Motion Flow Graph window.

The arrow turns white.



- 11 On the Motion Flow Graph toolbar, click Optimize Selected Transitions.

The Transition Optimization dialog displays.

- 12 If not already chosen, choose Search Entire Clip, then click OK.

Create a script:



- 1 On the Motion Flow rollout, in the Scripts group, turn on Define Script.

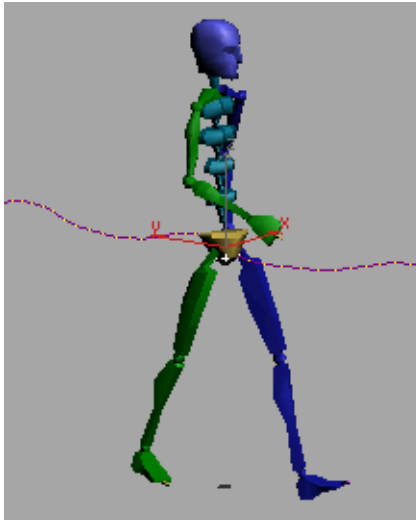

- 2 On the Motion Flow Graph dialog, click the *walk2loop* clip five times.
You've created a script that calls for the clip to transition to itself four times.

- 3 Click Play Animation.
The clip loops, extending the walk cycle.







Walking biped with trajectory turned on.

Make the motion available in your scene outside of Motion Flow mode:

-  1 Click the Define Script button on the Motion Flow rollout, in the Scripts group, to turn off scripting mode.
-  2 On the Motion Flow rollout, in the Scripts group, click Create Unified Motion. Then, in the Unify Options dialog, click OK to accept the defaults.
-  3 On the Biped rollout, turn off Motion Flow mode.
The walk cycle is available for editing outside of Motion Flow mode.

Add a layer and modify the walk cycle:

-  1 On the Layers rollout, click Create Layer.
A new layer is created.
-  2 Turn on Auto Key.
-  3 At frame 0, in the Front viewport, rotate both upper arms about the Y-axis to move the arms away from the body.
-  4 Click Play.
The walk loop now has the character swinging his arms farther from his body. The red stick figure represents the original motion.

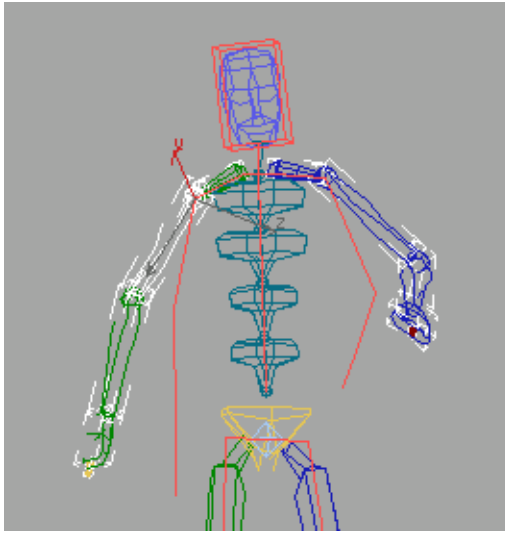

- 5 On the Layers rollout, click Collapse.

The layer showing the arms away from the body is collapsed into the base animation.

- 6 Turn off Auto Key and click Play Animation to watch the animation. You can also open *cs4_tut_moflow03.max* to see the finished animation.

Looping animations and layers lets you lengthen and modify animations.

- To reduce keys and create footsteps, save the BIP file, and then use Load Motion Capture File in the Motion Capture rollout to reload the file.
- To reduce keys and extract footsteps, use options in the Motion Capture Conversion Parameters dialog. The Convert command on the Bipod rollout will not extract footsteps because the feet have no IK Constraints applied.

Using a Shared Motion Flow

By including multiple bipeds in a shared motion flow, you can animate multiple bipeds using only one motion flow graph. The Create Random Motion command randomly picks clips to create a unique script for each biped. Use this feature to create a crowd that is loitering or cheering, for example.

Set up the lesson:

- 1 Reset 3ds Max.
- 2 In the Front viewport, create a biped at the far left side that is about 150 units in height.
- 3 In the Create Biped rollout, turn on Drag Position.

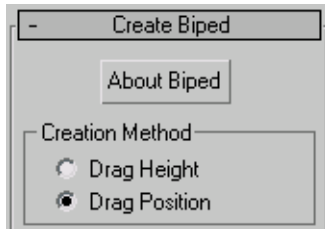

- 4 In the Front viewport, to the right of the original biped, click to create five more bipeds that are evenly spaced.

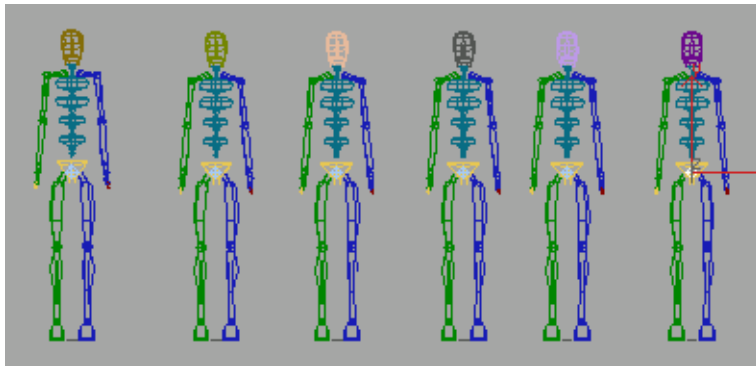

A total of six bipeds standing shoulder to shoulder.

Create a shared motion flow:

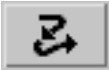
- 1  Open the Motion panel.
- 2  If not already selected, select the biped at the far right of the Front viewport and turn on Motion Flow Mode.

Selecting any part of the biped will enable biped controls in the Motion panel.



- 3 On the Motion Flow rollout, click Shared Motion Flow. The Shared Motion Flow dialog is displayed.

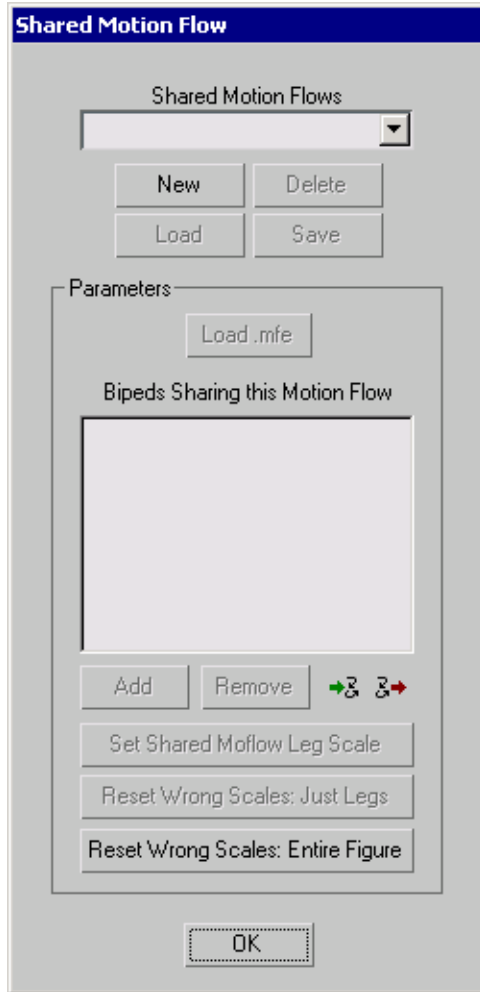

- 4 On the Shared Motion Flow dialog, click New.

A new shared motion flow is created. A default name appears in the Shared Motion Flows list.

- 5 On the Shared Motion Flow dialog, in the Parameters group, click Add. The Select dialog is displayed.

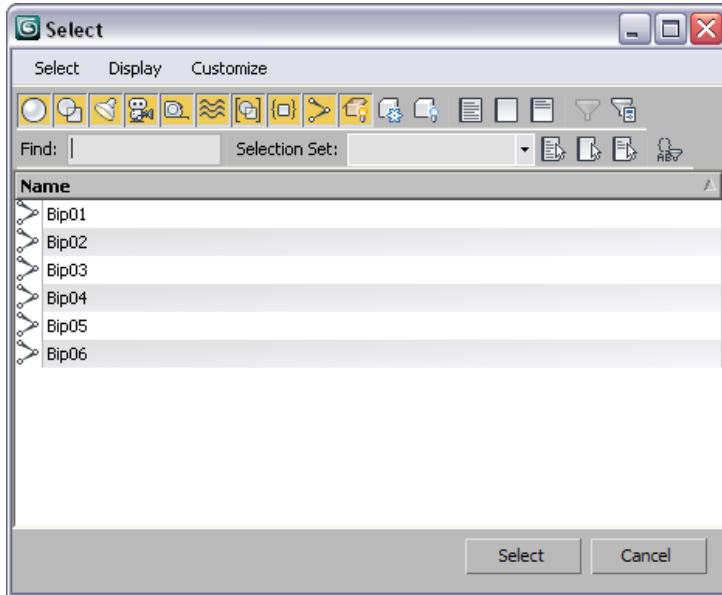

- 6  Click the Select All button, then click Select.

The biped names are displayed in the Shared Motion Flow dialog.

NOTE You might receive a Biped warning indicating that the scale of the legs of all the biped must match. If you see this, click OK to close the warning. Then, on the Shared Motion Flow dialog, click Reset Wrong Scales: Just Legs. (If you choose to Reset Wrong Scales: Entire Figure, all the bipeds will occupy the same space as the first biped. You don't want that.)

- 7 On the Shared Motion Flows dialog, click OK.



The Shared Motion Flow button on the Motion Flow rollout now has a white circle around it. This means that the selected biped is part of a shared motion flow.

Create a shared motion flow script:



- 1 On the Motion Flow rollout, click Show Graph.
The Motion Flow Graph is displayed. The word **SHARED** appears in the graph name. This Motion Flow Graph will be shared by the six bipeds.



- 2 On the Motion Flow Graph toolbar, click Create Multiple Clips.
- 3 From the `\sceneassets\animations\` folder, add *hatsoff.bip*, *laugh.bip*, *shocked.bip*, *sneeze.bip*, and *wave.bip*. Hold down the Ctrl key and click each file name to add it to the selection. Click Open

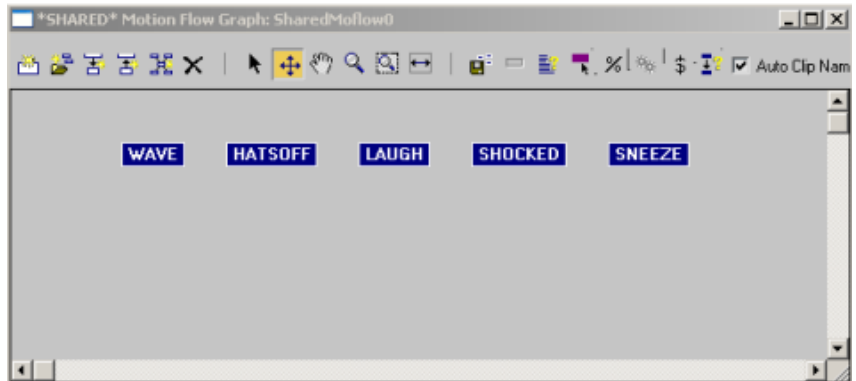



The selected clips are added to the Motion Flow Graph.

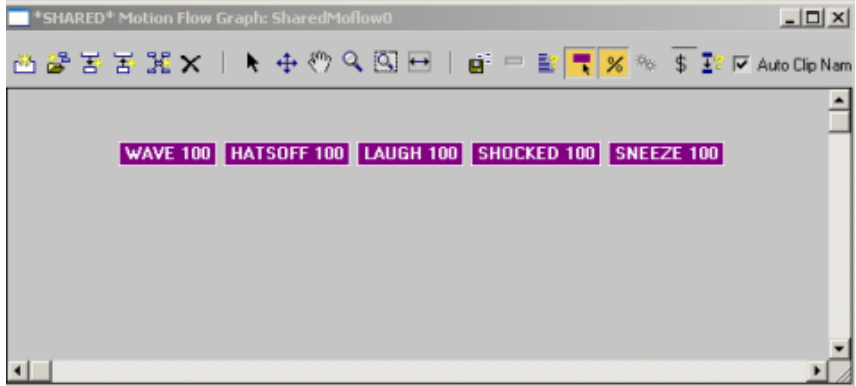

- 4 On the Motion Flow Graph toolbar, click Select Random Start Clips and drag a selection window around all the clips.
The clips all turn purple and show a Random Start Probability of 100, meaning that each clip has an equal chance of being chosen first.



TIP If you wanted all the bipeds to start their movement using the same clip, you would reduce the Random Start Probability values of all but the clip you want all the bipeds to use first. Right-click a clip to display its parameters dialog.

- 5   Turn on the Select Clip/Transition button, and then turn off the Show Random Percentages button.
- 6 Drag a selection window around all the clips in the Motion Flow Graph.

- 7  On the Motion Flow Graph toolbar, click Create All Transitions. You are asked if you want to create transitions from each selected clip to itself. Click Yes.

Transitions appear between all the clips.

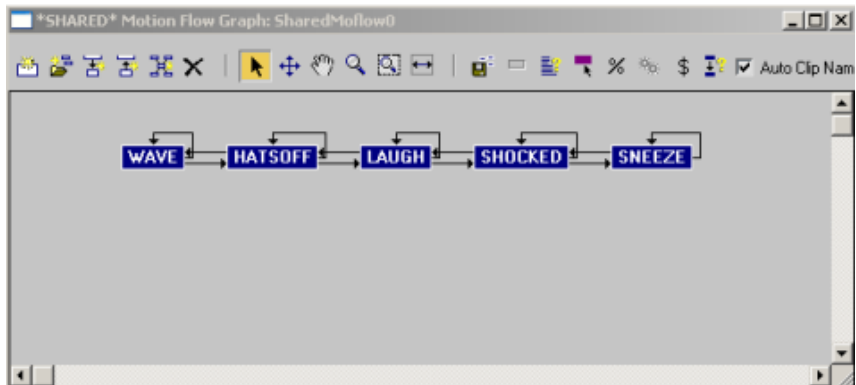



- 8 On the Motion Flow rollout, in the Scripts group, click Create Random Motion.

The Create Random Motion dialog displays.

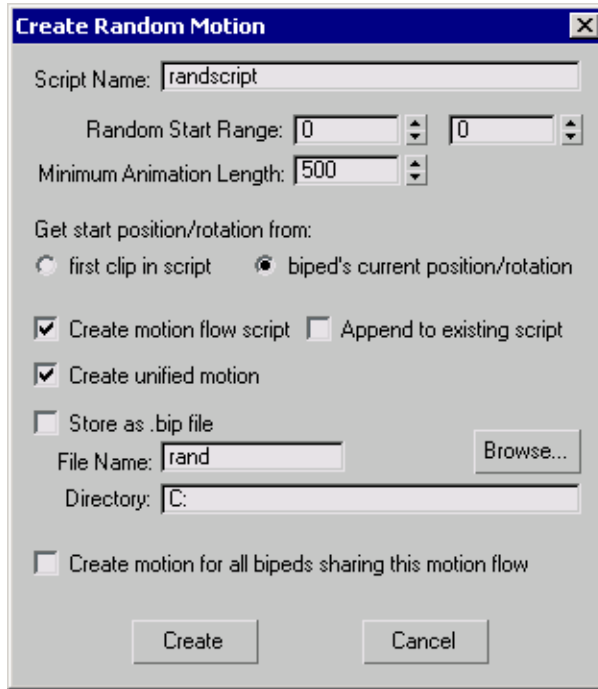

- 9 On the Create Random Motion dialog, set Random Start Range from **0** to **30**.
Each biped has a random script based on the clips in the Motion Flow Graph. If two bipeds share a clip, the clip's start frame is picked randomly. This prevents identical motion.
- 10 On the Create Random Motion dialog, turn on “Create motion for all bipeds sharing this motion flow”, then click Create.
The Unify Options dialog appears. It will appear for each biped you're creating a motion for.
- 11 Click OK to accept the default settings on the Unify Options dialog each time it pops up.

- 12 An alert asks if you want to put all the bipeds into Motion Flow mode. Click Yes.
The bipeds appear with footsteps, ready to begin their random motion routine.

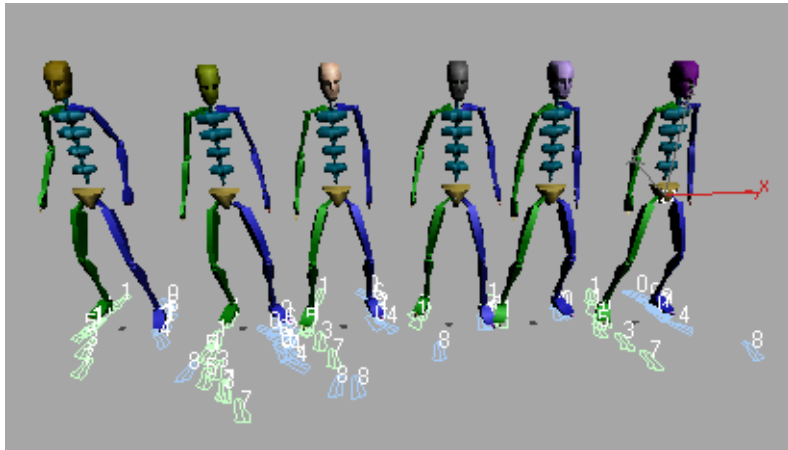

Play and save the animation.

- 1 Activate the Perspective viewport. Use Orbit, Pan, and Field-of-View so you can see all the bipeds.
- 2  Click Play Animation.
Each biped moves to its own script that is compiled from the assortment of clips you added to the Motion Flow Graph.
- 3 Save the scene as **MyMoFlow02.max**.

Creating Random Motion





This lesson illustrates how to use the Create Random Motion feature with clips in the Motion Flow Graph to create interesting scenarios quickly. It uses an available set of *.bip* motion files.

You'll add four figure-skating motions to the Motion Flow Graph, create a network of transitions, and generate a random script to animate the biped.

Set up the lesson:

- 1 Reset 3ds Max.
- 2 In the Perspective viewport, create a biped starting at approximately 0,0,0.

Add clips to the Motion Flow Graph:

- 1  Open the Motion panel.
- 2  On the Biped rollout, turn on Motion Flow Mode.
- 3  On the Motion Flow rollout, click Show Graph.
The Motion Flow Graph displays.
- 4  On the Motion Flow Graph toolbar, click Create Multiple Clips.
- 5 Hold down Ctrl, and from the `\sceneassets\animations\` folder, select the following four motion files: *skateup.bip*, *skatestart.bip*, *skateloop.bip*, and *skatespin.bip*. Click Open.
The motion files load into the Motion Flow Graph.

Arrange the clips:



- 1  On the Motion Flow Graph toolbar, turn on Move Clip.
- 2 Arrange the clips in a column with *Skateup* at the bottom, then *SkateStart*, *SkateLoop*, and *SkateSpin*.

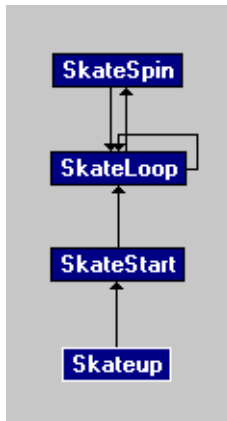

Set and optimize transitions:

- 1  On the Motion Flow Graph toolbar, turn on Create Transition From->To.
- 2 In the Motion Flow Graph window, click and drag from one clip to the next to create transitions between the clips. Start with *Skateup* and drag to *SkateStart*, then *SkateLoop* and finally *SkateSpin*.
Use the illustration as a guide to create the transitions. To create a loop, click a clip twice.



- 3   Turn on Select Clip/Transition and region-select all the clips. Then, on the Motion Flow Graph toolbar, click Optimize Selected Transitions.

The Transition Optimization dialog displays.

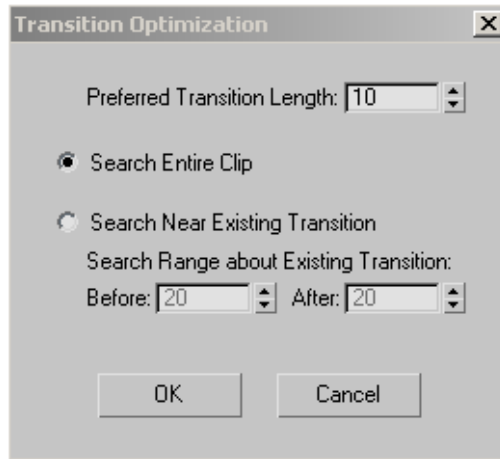

- 4 Make sure that Search Entire Clip is active and click OK.
- 5  On the Motion Flow Graph toolbar, turn on Show Random Percentages.

A percentage number displays next to each transition.

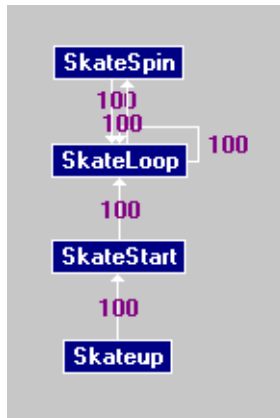

You'll alter the percentages for the loop transition and the transition between *SkateLoop* and *SkateSpin*.

- 6 In the Motion Flow Graph window, right-click the loop transition arrow on the *SkateLoop* clip (not the box representing the clip).

The Transition Editor dialog displays, with the name of the transition in the title bar.

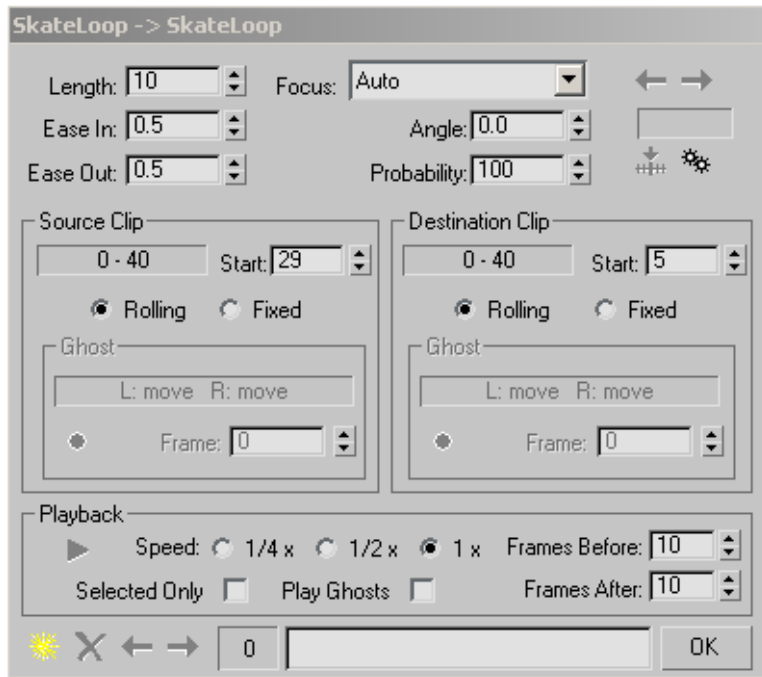



- 7 On the upper left of the Transition Editor dialog, enter **85** in the Probability field. Click OK.

The random percentage next to the transition arrow is updated.

- 8 In the Motion Flow Graph window, right-click the transition from *SkateLoop* to *SkateSpin*. On the Transition Editor dialog, enter **15** in the Probability field. Click OK.

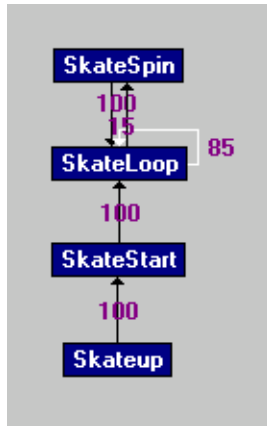
When 3ds Max generates a random script, *SkateLoop* will be chosen over *SkateSpin* 85 percent of the time. The percentage numbers in the Motion Flow Graph are normalized, so if two transitions from a clip are set at 100, each one has an even chance of being selected.



- 9  On the Motion Flow Graph toolbar, turn on Select Random Start Clips, and click *Skateup*.
The *Skateup* clip turns purple. It will always be the first clip to play when 3ds Max generates a random script.

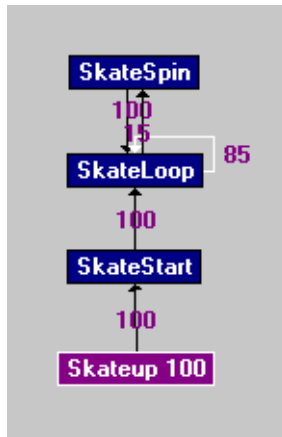

- 10 Close the Motion Flow Graph window.

- 11  On the Motion Flow rollout, in the Scripts group, click Create Random Motion.

The Create Random Motion dialog displays.

- 12 In the Minimum Animation Length field, enter **2000** and click Create. On the Unify Options dialog, click OK to accept the defaults. A random script is generated.

NOTE If the biped's start position looks like it is floating above the grid, set the Start Position Z value to **0** on the Motion Flow rollout. This will position the entire animation back on the ground plane.

- 13 Click Play Animation to view the results.

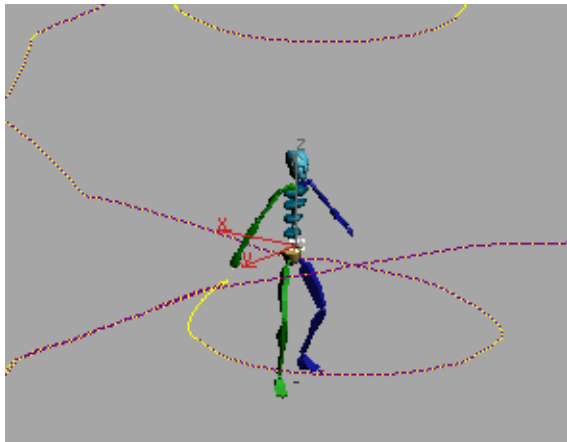

The skater gets up off the ice and begins skating. Once the script reaches the *SkateLoop* clip it loops back to *SkateLoop* 85 percent of the time and *SkateSpin* 15 percent of the time.

- 14  To get a bird's eye view of the entire motion, press **H** and select the biped center of mass (*Bip01*). Open the Modes and Display expansion bar on the Biped rollout. In the Display group, turn on Trajectories, then restart the animation.

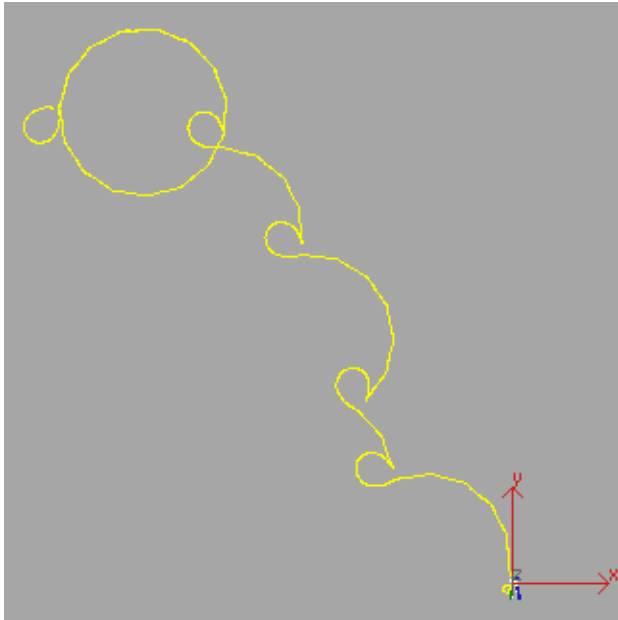

The trajectory of the scripted motion, as seen in the Top viewport.

NOTE Keep in mind that, since you're using Create Random Motion, your motion will not necessarily look like the one above.

15 Save the scene as **MyMoFlow03.max**.

Summary

Upon completion of this tutorial, you're now able to assign motion clips to a biped and adjust the transition between a clips or set up a looping operation for a clip. You also know how to create a random script for one biped or multiple bipeds. Finally, you created a random script that always start with a specific clip and some of the random clips have a greater chance of being used than others.

Adjusting the Biped to the Model

This tutorial shows you how to adjust a biped model in various ways, including the Knuckles feature that is new to Autodesk 3ds Max 2010. It also shows how to use the Physique modifier to associate a biped with a mesh, and fine-tune that association.



In this tutorial, you will learn how to:

- Customize the biped structure.
-  Use Knuckles to create a detailed hand, and animate it.
- Pose the biped to fit the mesh.
- Adjust vertex assignments with envelope parameters.
- Use control points to fine-tune the shapes and sizes of envelopes.
- Adjust envelopes in shoulder and hip areas for the best deformation.

Skill level: Beginner

Time to complete: 2.5 hours

Working with Biped Parts

The process of animating a character starts with a biped. In this lesson, you will learn to work with biped parts, creating a skeleton with the appropriate body parts to fit your mesh.

Set up the lesson:

- Reset 3ds Max.

Create a biped:

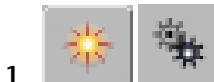

- 1 On the Create panel, click Systems.
- 2 On the Object Type rollout, click Biped.
The Biped button turns gold.
- 3 If you can't see the Height spinner in the Create Biped rollout, scroll to the bottom of the command panel.
- 4 In the Perspective viewport, place the mouse cursor over the center of the grid. Press and hold the mouse button and drag upward.
A biped appears and grows with your cursor movement.
- 5 Drag upward until the Height value is approximately **70** units. A biped appears in the viewport.



The biped is a hierarchy of special objects. Its parent object (*Bip01*) is also called the center of mass or COM. The COM is displayed in the viewports as a small tetrahedron, initially centered in the biped's pelvis. After you create a biped, only the center of mass object is selected (not the entire biped).

After creating the biped, you change the values on the Create Biped rollout to give the biped the appropriate links for your mesh.

Change the number of fingers and toes:

- 1 Change the Fingers parameter to different values. You can see the number of fingers changing in viewports.

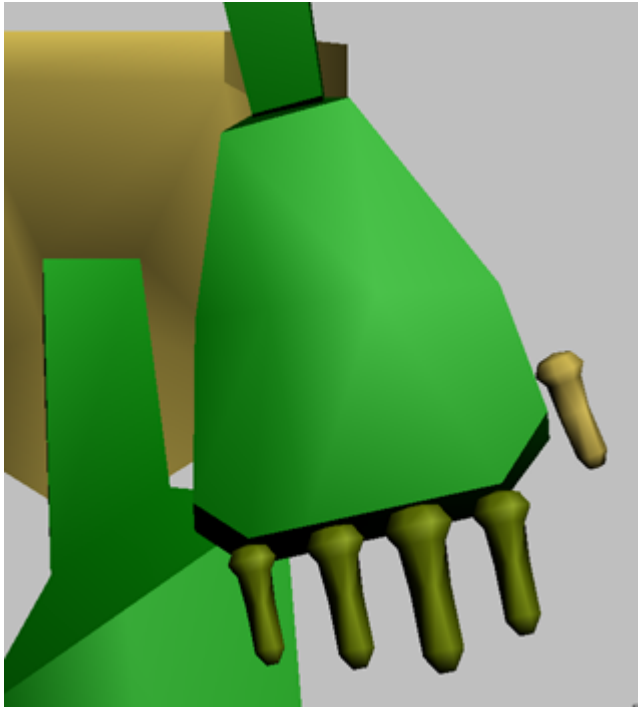

Five fingers

- 2 Set the number of Fingers to **5**. This gives the biped four fingers and a thumb.
- 3 Change the Finger Links parameter to different values. Observe the finger links as they change in viewports.

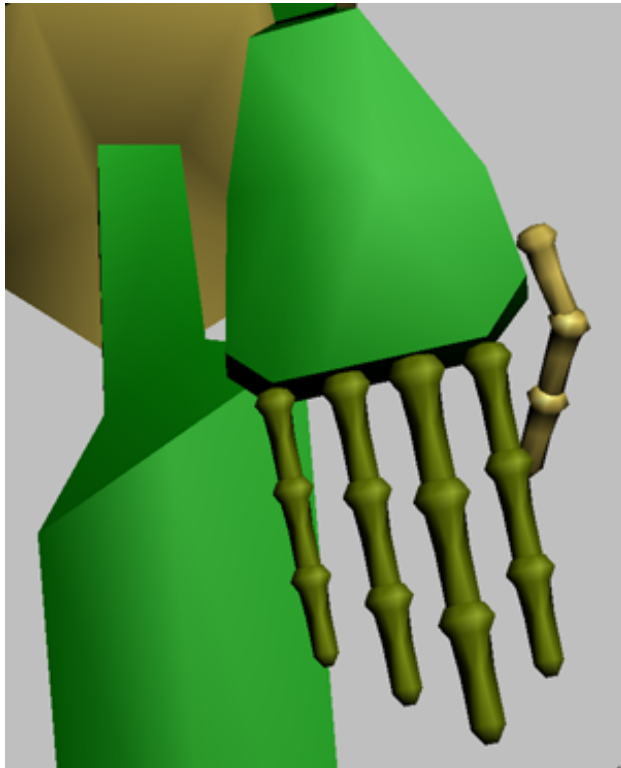

Five fingers with three finger links

- 4 Experiment with the number of Toes and Toe Links, and observe the changes in viewports.

NOTE  With the Knuckles feature, you can create even more detailed hands. See [Using the Knuckles Toggle for Detailed Hand Animation](#) on page 879.

Add a tail and ponytails:

For non-human characters such as animals, you will need tail and ponytail links to control the mesh.

- 1 Change the Tail Links value to 5.
In the Left viewport, you can see the biped growing with a tail.

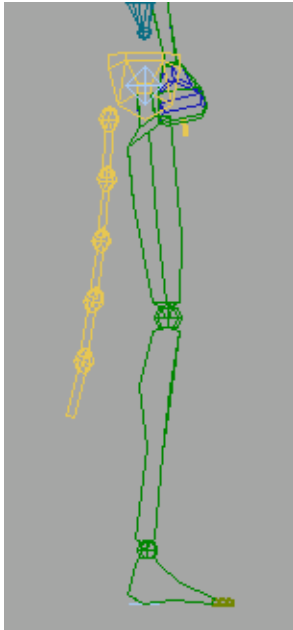

Biped with tail

As long as this biped remains selected, you can make changes to the biped parameters and see the effects.

- 2** Change the Tail Links spinner to **0**.
- 3** Change the Ponytail1 Links value to **5**.

In the Left viewport, you can see the ponytail growing from the base of the head. If necessary, two ponytails can be added.

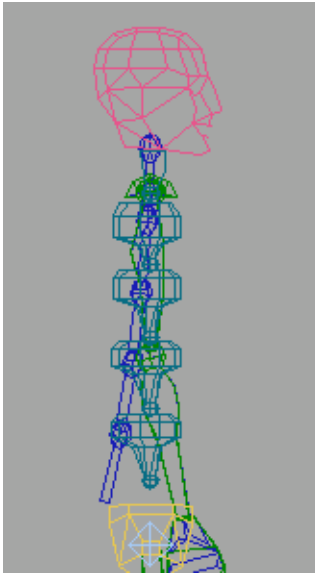

Biped with one ponytail (in blue)

- 4 Change the Ponytail1 Links value to **0**.

Add props:

Props are extensions of the biped skeleton. Props are linked to the COM, and can be animated to pass from hand to hand. You can use props to animate objects the biped is holding, such as tools or weapons.

- 1 Turn on Props 1, 2 and 3, and turn them off again.

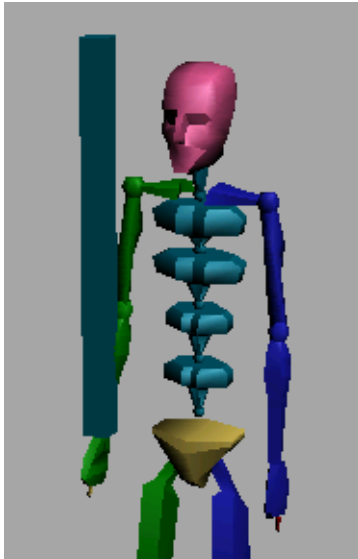

Biped with Prop 1 activated

Once you have determined the appropriate parts for your biped, the next step is to align the biped to the mesh.

- 2 If you like, you can save this scene to the file **my_biped.max**.

Using the Knuckles Toggle for Detailed Hand Animation



The Knuckles toggle in Autodesk 3ds Max 2010 lets you create detailed, subtle hand animation.

Set up the scene:





- From the Application menu, choose Reset.

Create the biped:

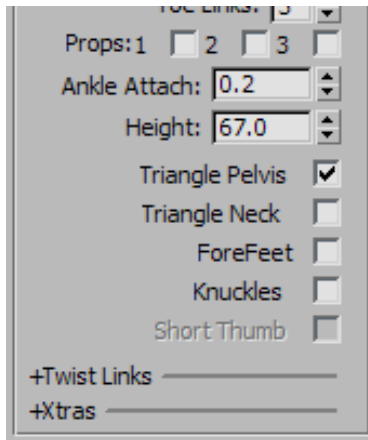
- 1   Go to the Create panel, turn on Systems, and then click the Biped button to turn it on.
- 2 Drag in the Perspective viewport to create a biped about **67** inches tall. You can set Height on the Create Biped rollout on the Command panel.



Give the biped a hand with knuckles:

- 1   Go to the Motion panel, and then turn on Figure Mode.
- 2 Expand the Structure rollout. Click the Knuckles toggle to turn it on. When you click Knuckles, a couple other things happen:
 - The Short Thumb toggle becomes available. By default, it is on.
 - The value of Fingers changes to 5.
 - The value of Finger Links changes to 4.

These defaults for the Knuckles option model a human hand. You can change them if you're modeling a nonhuman character.

- 3  With the Perspective viewport active, change Field-Of-View to Zoom Region, and then zoom in on the area around the biped's pelvis and hands.

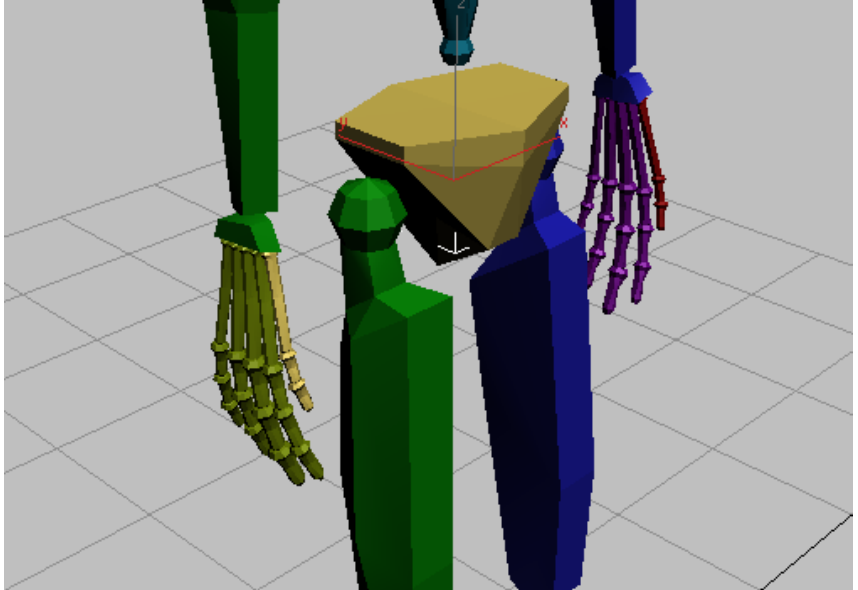

When you turn on Knuckles for a biped, the hands are much more detailed than the default hands.

- 4  Click Figure Mode to turn it off.

Begin to animate a “come here” gesture:

- 1  Click Auto Key to turn it on.
- 2 Change the Reference Coordinate System to Local.

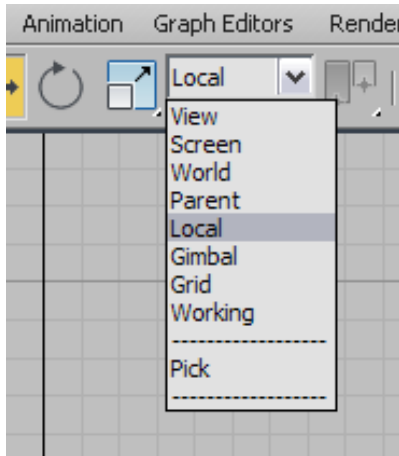

- 3 Select the biped's right hand, and move it forward so it is in front of the body.

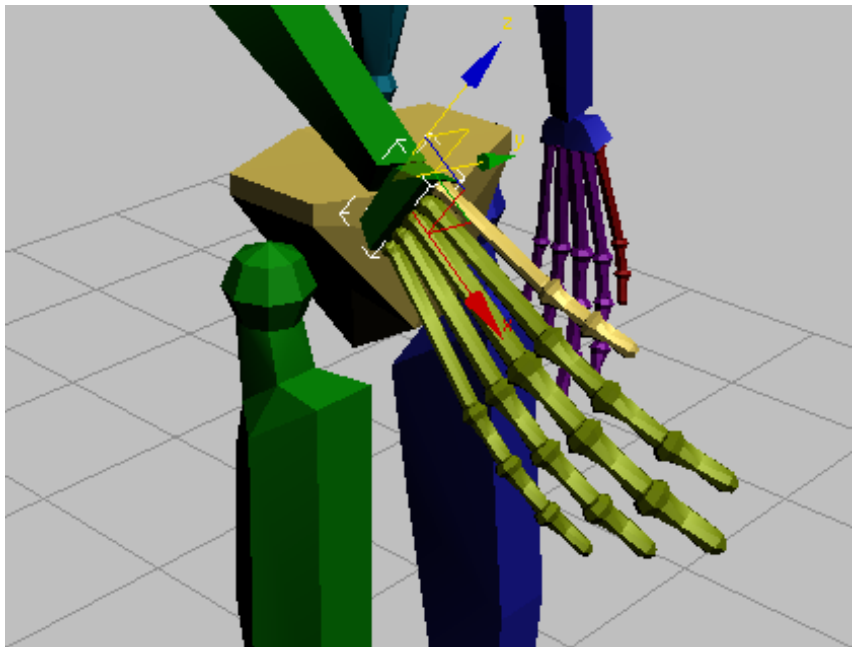



- 4 Drag the time slider to frame 7, then rotate the hand so the palm is facing up: about 100 degrees in the local X axis.

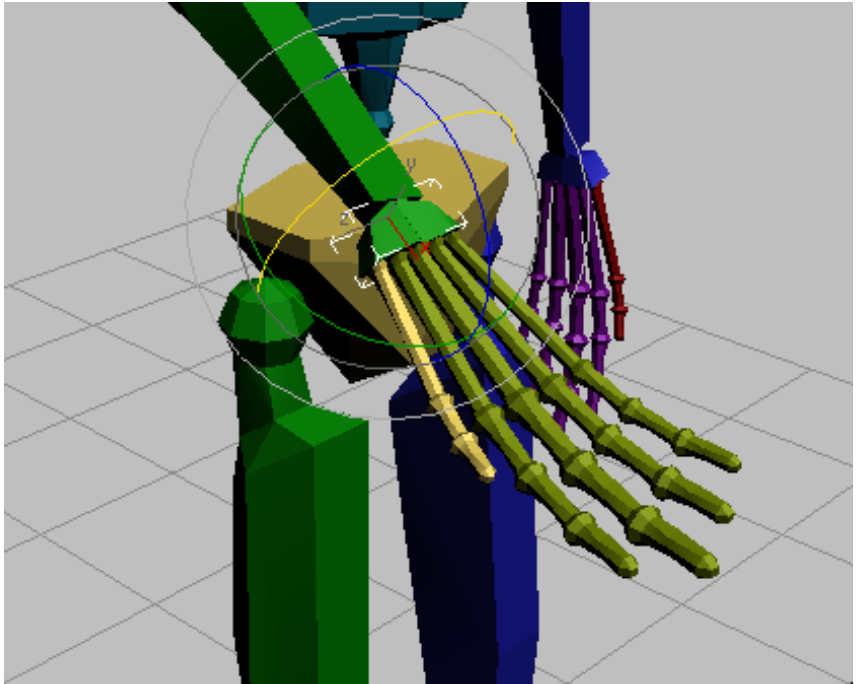

- 5 Drag the time slider to frame 10.



- 6 Press Page Down to select the first link in all fingers. Turn on Select Object, and then Alt+click to deselect the first link of the thumb.

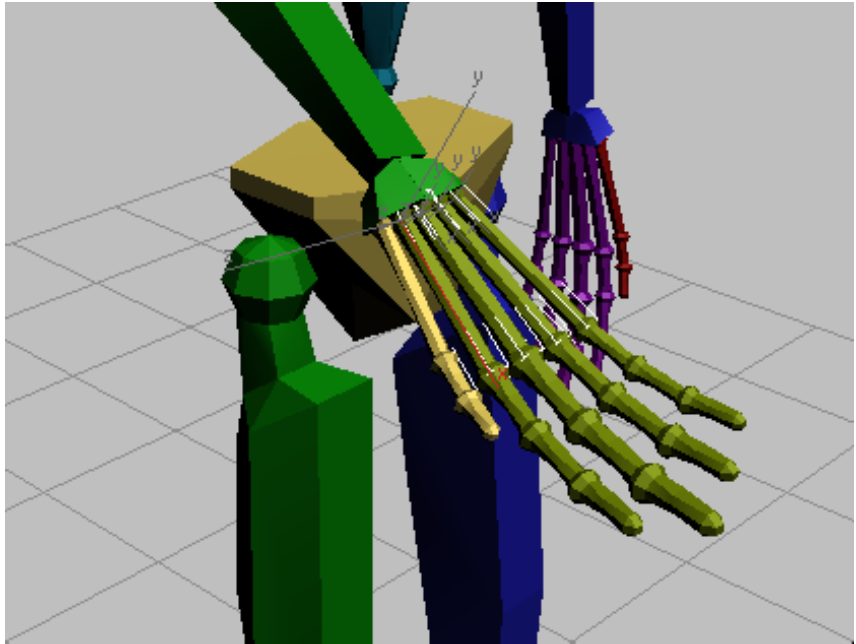

- 7 Rotate the first links up slightly: about 5 degrees in the local Z axis.
-



TIP Before you do these rotations, you might want to turn on the Angle Snap Toggle, which makes all rotation snap to 5-degree increments. (The illustrations and sample scene were created without Angle Snap.)

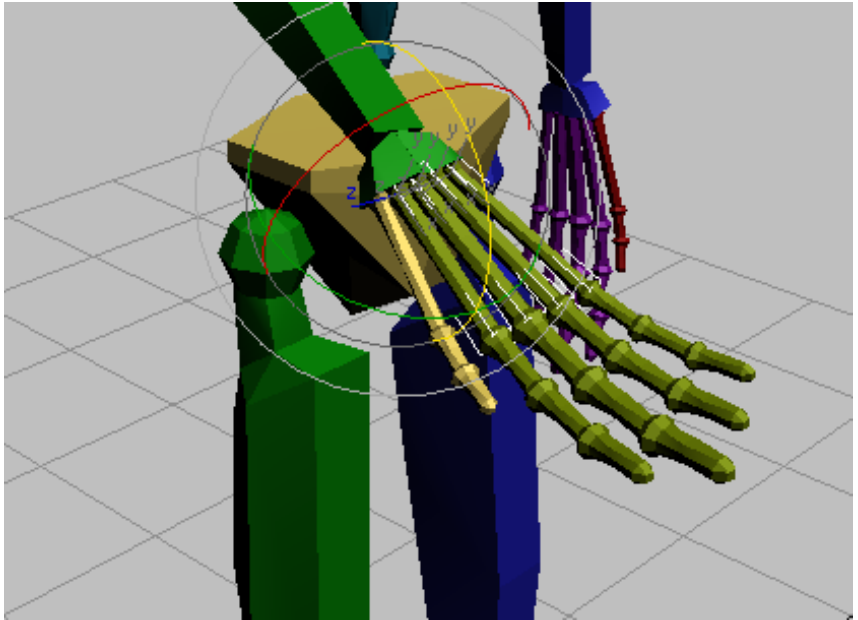

- 8 Drag the time slider to frame 12. Press Page Down to select the second link of the four fingers, then rotate the joints up a little more: about **10** degrees in the local Z axis.

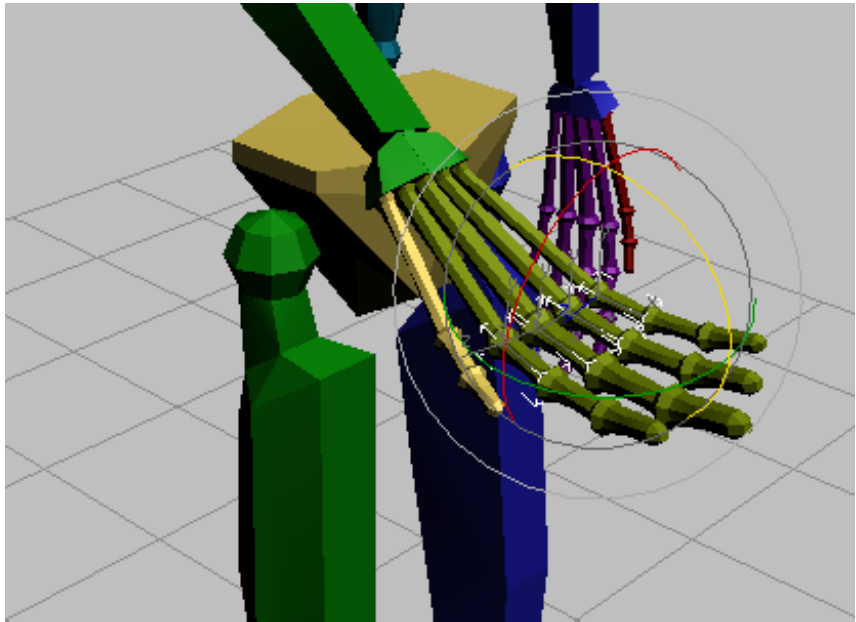

NOTE The finger links in a hand with Knuckles have three degrees of freedom: they are much more flexible than in a human hand. Be aware, though, that the Bend Links options don't work for fingers as they do for the spine, neck, and tail. When you bend fingers, you need to animate each link explicitly.



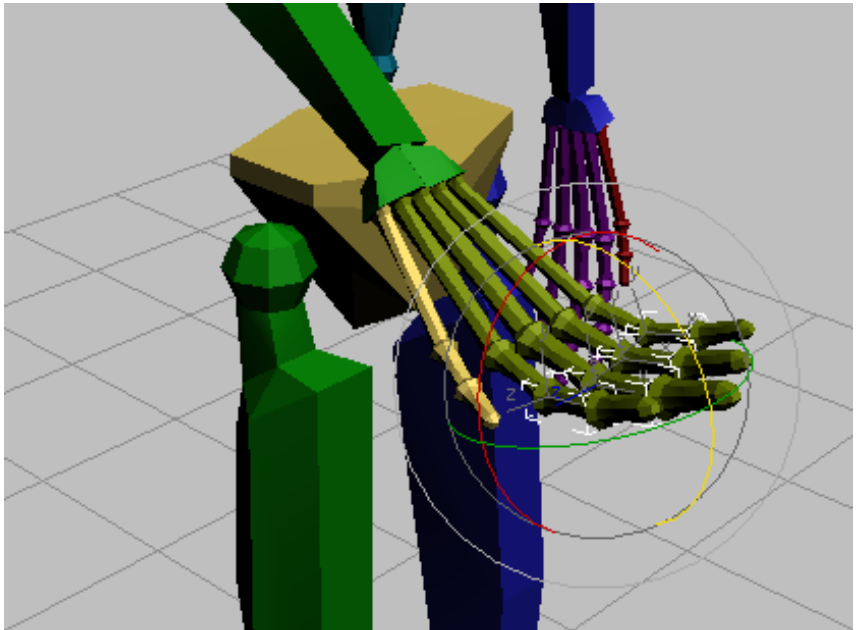

- 9 Drag the time slider to frame 14. Press Page Down to select the third link of the four fingers, then rotate the joints up a little more: about **15** degrees in the local Z axis.

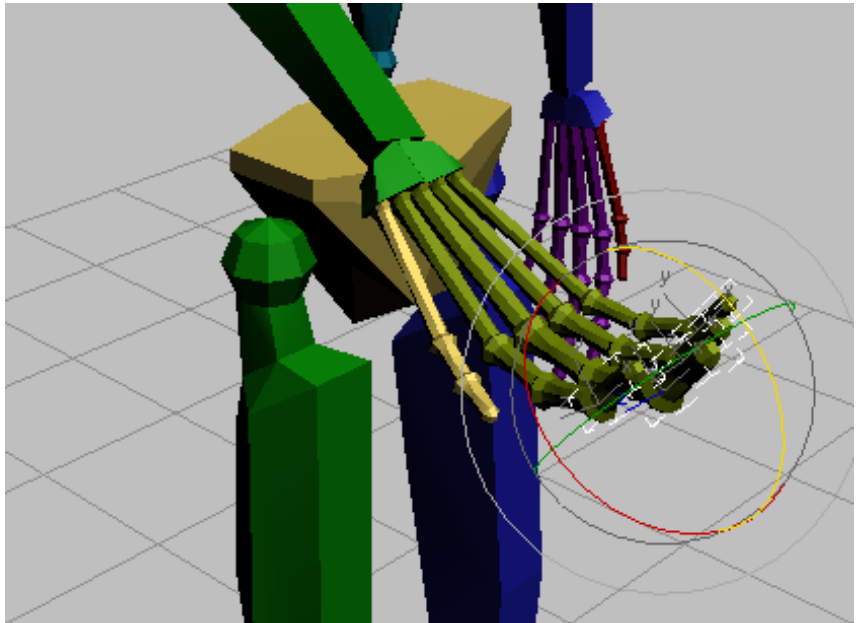

- 10  Drag the time slider to frame 16. Press Page Down to select the fourth and last link of the four fingers, then rotate the joints up still more: about **25** degrees in the local Z axis.



Reverse the finger curling:

- 1  Make sure Auto Key is still on, and that the Reference Coordinate System is Local.
- 2  Animate the fingers uncurling, as follows:
 - At frame 20, rotate the fourth links about -25 degrees in the local Z axis.
 - At frame 21, press Page Up, then rotate the third links about -15 degrees.
 - At frame 24, press Page Up, then rotate the second links about -10 degrees.

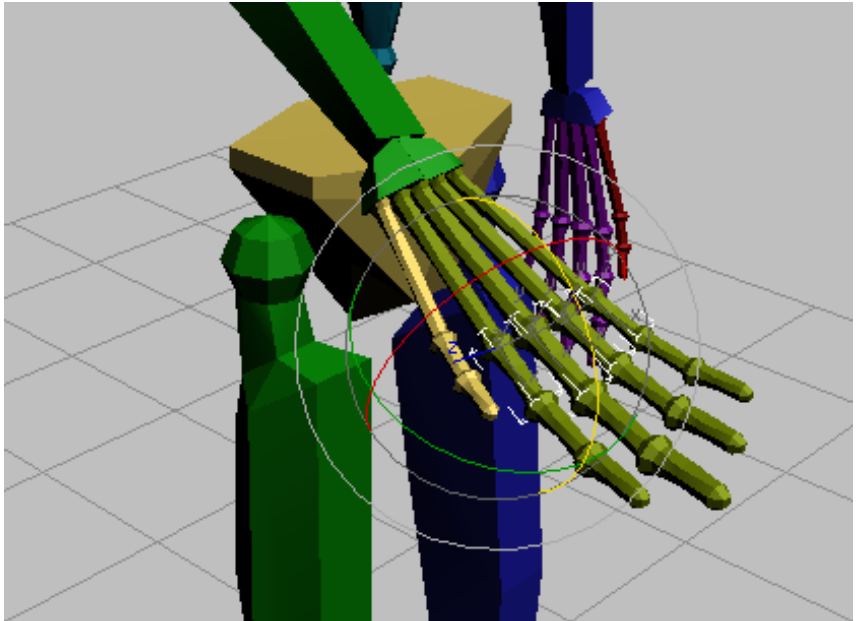

Repeat the gesture:

- 1 On the track bar, drag a box to select the finger keys from frames 7 to 24.

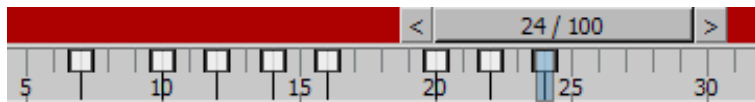

- 2 Shift+drag the selected keys to repeat the gesture beginning at frame 30.

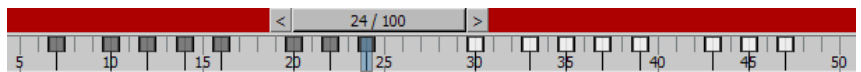

The range of the duplicated gesture is from frame 30 to frame 47.

- 3 Drag a box to select the keys from frames 30 to 39.

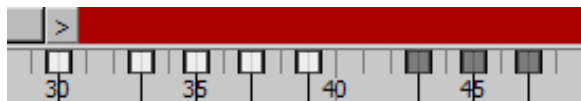

This time, you are duplicating only part of the gesture.

- 4 Shift+drag the keys to repeat the partial gesture beginning at frame 50.



Change the gesture to a pointing finger:

- 1 Drag the time slider to frame 70.



- 2 Select the hand, and rotate it so it's vertical: about -90 degrees in the local X axis.



- 3 Select the second link of the thumb, and rotate it upwards: about -50 degrees in the local Y axis.

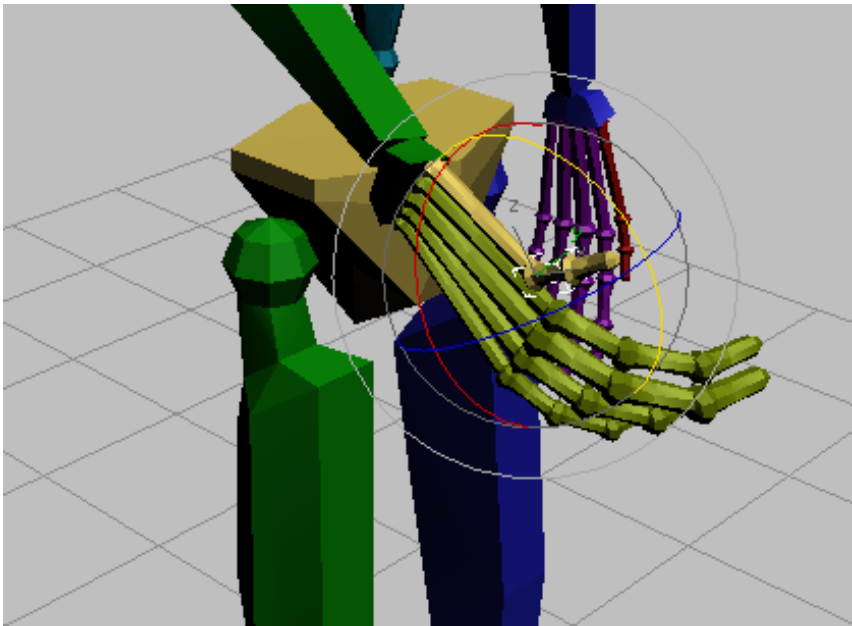



- 4 Also at frame 70, one at a time rotate the second, third, and fourth links of the index finger so the finger points to the left. Rotating just one link at a time helps keep the finger from curling.

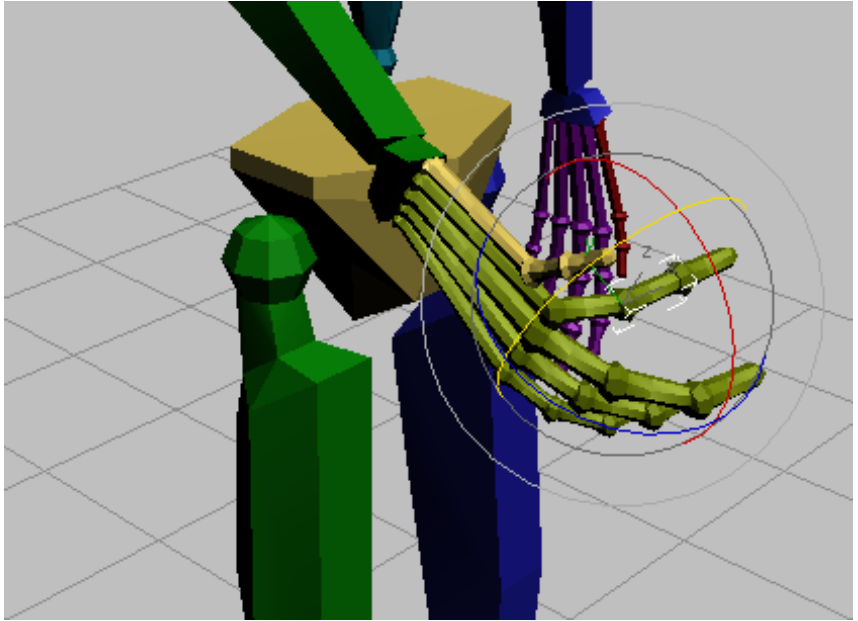

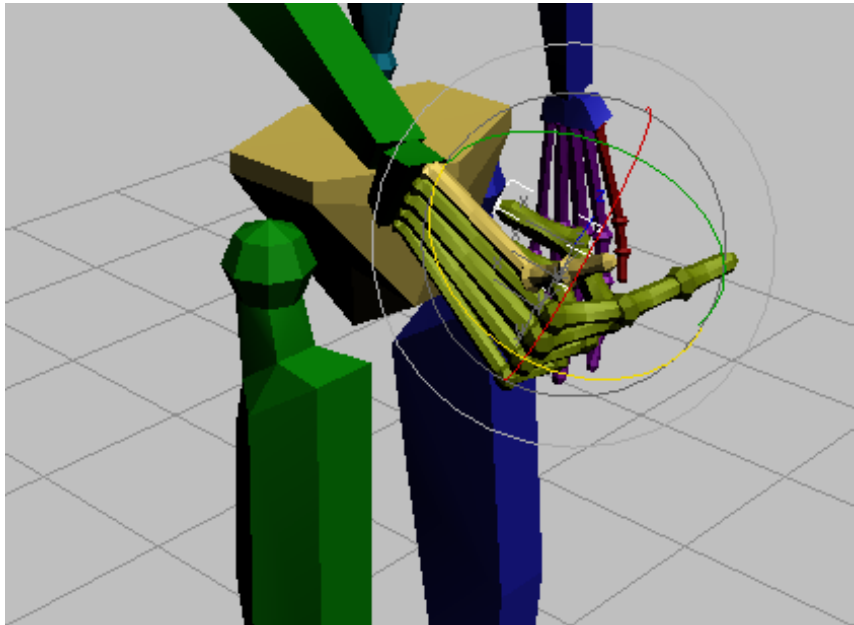

- 5 Finally, still at Frame 70, rotate the second, third, and fourth links of the remaining fingers so they are folded toward the palm of the hand.



TIP Ctrl+click to select the second link of all three fingers (fingers 3 to 5), and then use Page Up or Page Down as you rotate, just as you did earlier in this lesson.

- 6  Turn off Auto Key.

View the animation:

-   Scrub the time slider, or click Play and the Stop, to see the animation.

The hand makes a beckoning gesture three times, then points to the left.

TIP If you want to fine-tune a hand animation by adjusting keys individually for the fingers, first expand the Keyframing Tools rollout on the Motion panel, and in the Separate FK Tracks group, turn on the Fingers toggle.

Save your work:

- Save your work as **biped_beckoning.max**.
To see a completed version of this animation, you can open the scene *\knuckles\knuckles_finished.max*.

Aligning the Biped to the Model

In this lesson, you'll pose a biped to fit a specific character by moving, rotating, and scaling biped parts.

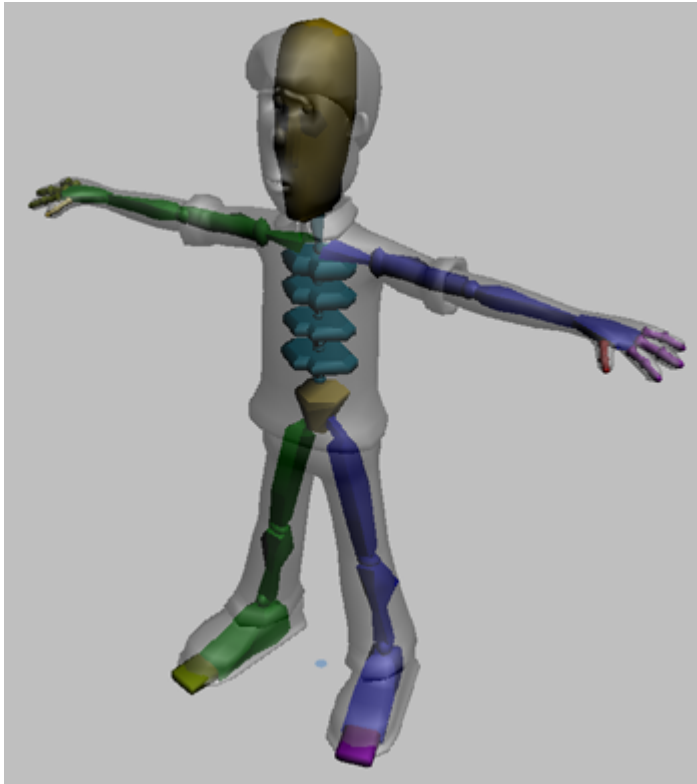

When correctly posed, the biped's torso, arms, and legs fit just inside the mesh. Fingers and toes extend just beyond the mesh to make skinning easier later on.

When posing the biped, Figure mode must be turned on. This mode tells 3ds Max that you are posing the biped rather than animating it.

The character you'll use in this lesson has a human form, and will not require a tail, ponytails, or props

Set up for this lesson:

- 1  On the Quick Access toolbar, click the Open File button, navigate to the `\animation\character_animation\physique_basics` folder, and open `align_wilson_start.max`.

This scene contains a model of a man named Wilson.



The Wilson model

- 2 Inspect the model to see the number of fingers and toes. This model has three fingers and a thumb, and the fingers are short. Wilson is wearing shoes, so no toes are visible.

Prepare the model:

Your work with the biped will be much easier if you make a selection set for the model, make it see-through, and freeze it.

- 1 Select the entire model.
- 2 In the Named Selection Sets entry area on the main toolbar, enter the name **Wilson Mesh**.
- 3 On the Display panel > Display Properties rollout, turn on See-Through.



The model turns gray and becomes see-through. Making the model see-through will allow you to see the biped as you pose it inside the model.

- 4 On the Display panel > Display Properties rollout, turn off Show Frozen in Gray.
This lets the model retain a little of its shading when frozen.
- 5 On the Display panel > Freeze rollout, click Freeze Selected.
You freeze the model so you won't accidentally select it while working with the biped.

Create a biped:

- 1 Choose Create panel > Systems > Biped.
- 2 Click near Wilson's feet in the Front viewport and drag upward to create a biped about the same size as the model.

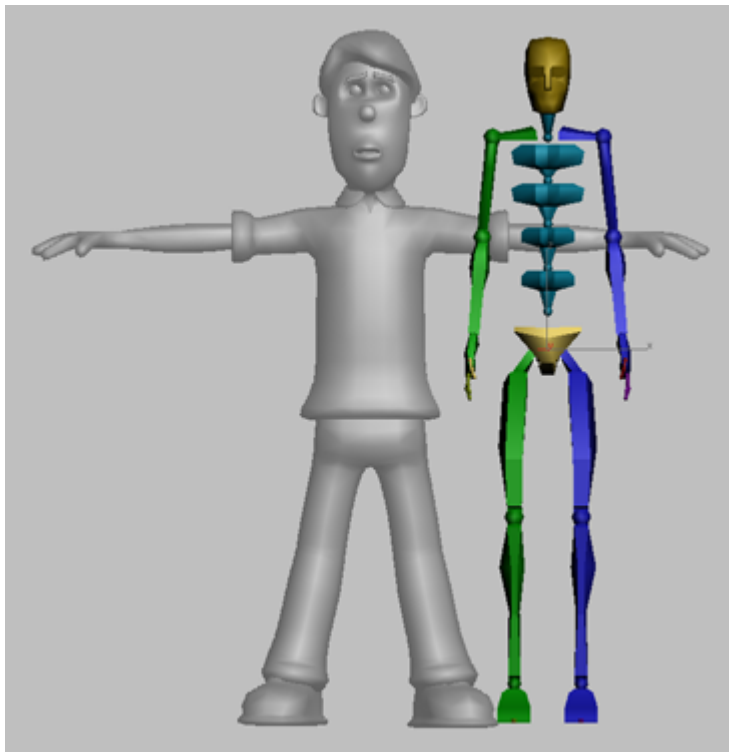

Because Wilson is wearing shoes, there's no reason to have separate toes. You'll give the biped just one toe with one link, which will control the entire ball and toe of the shoe.

- 3 Near the bottom of the Create Biped rollout, change Toes to **1** and Toe Links to **1**.

When you inspected the model earlier, you found that Wilson has three fingers and a thumb for a total of four fingers. The fingers are short, so only two finger links are needed.

- 4 Set Fingers to **4** and Finger Links to **2**.

Wilson's neck is rather stubby, so he needs only one neck link.

- 5 Set Neck Links to **1**.

Position the biped:

- 1  Open the Motion panel.

- 2  In the Biped rollout, click Figure mode to turn it on.

If the Biped rollout doesn't appear on the Motion panel, select any part of the biped to make it appear.

IMPORTANT Be sure to turn on Figure mode before continuing. Figure mode will retain the pose you are about to create.

- 3 Select the center of mass (COM), the blue tetrahedron at the center of the biped's pelvis.

TIP  You can quickly select the COM by clicking any of the selection buttons in the Track Selection rollout: Body Horizontal, Body Vertical, or Body Rotation.

- 4 In the Front viewport, move the COM to the center of the model's hips.

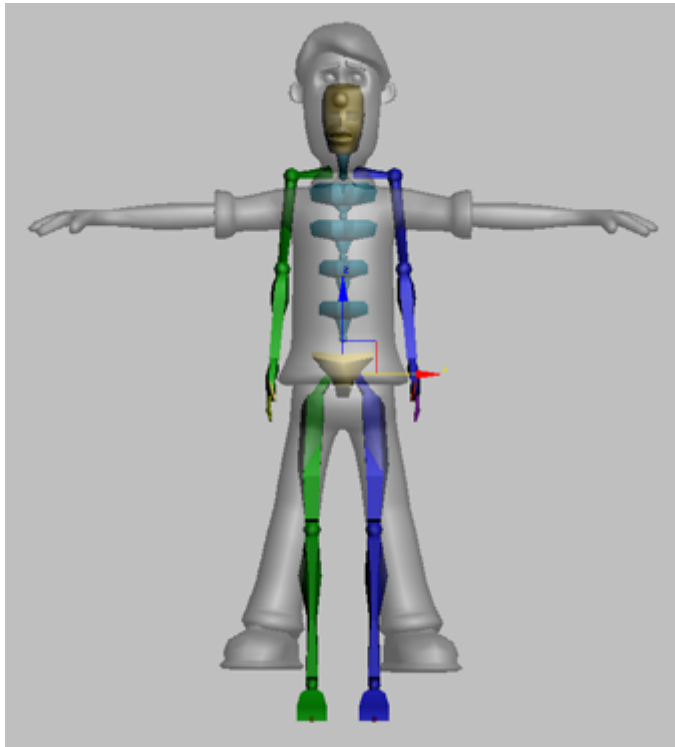

- 5 Check in all viewports and move the COM as necessary to put it inside the character's hips.

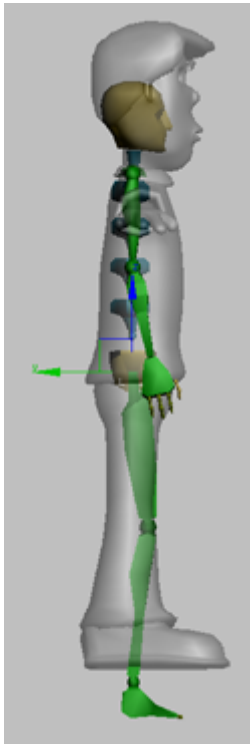

COM placed correctly in Left view.

Pose the legs:

- 1 Select both the upper and lower parts of both legs.
- 2 In the Front viewport, scale both legs so the bottoms of the biped's feet align with the model's feet.

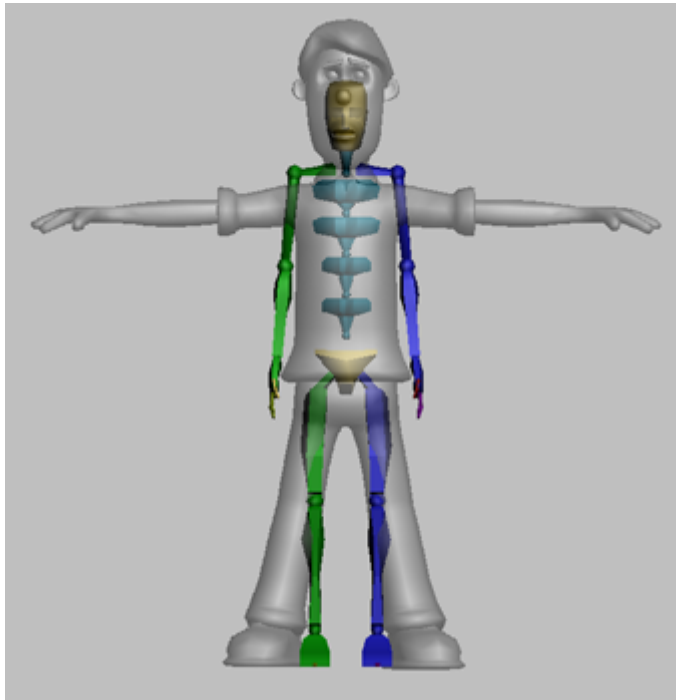

- 3 Select both thighs. Rotate the thighs to make the biped's legs parallel to the mesh legs.

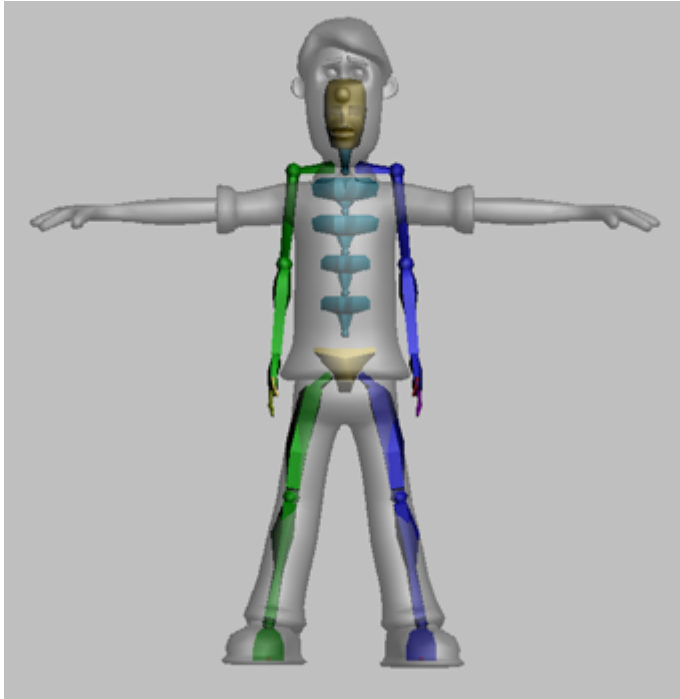

The goal is to make the biped's legs go down the centers of the mesh legs, but you can't do it until you scale the pelvis.

- 4 Select the biped's pelvis, the orange triangle around the COM.
- 5 Scale the pelvis on its local Z-axis so the biped legs go down the centers of the mesh legs.

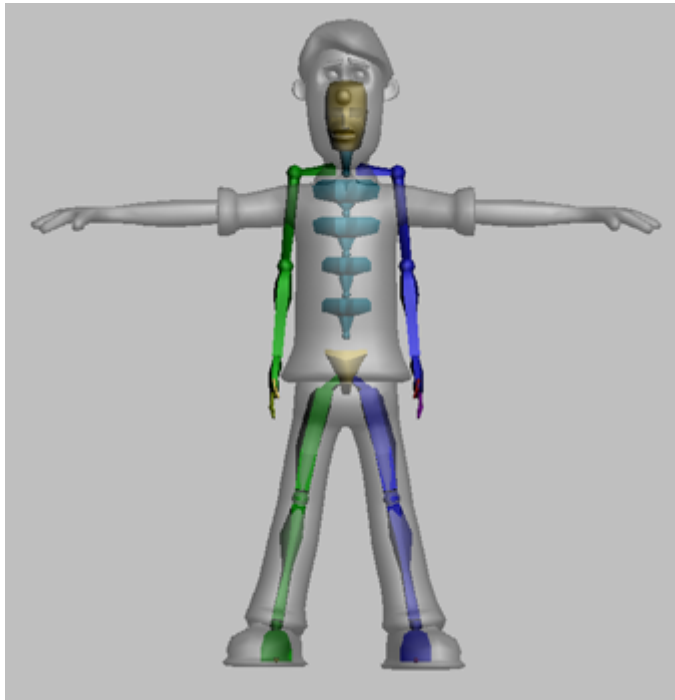

You might need to rotate the legs again, and scale the pelvis again. Work back and forth between scaling the pelvis and rotating the legs until the legs go straight down the middle of the mesh legs.

Scale the legs:

- 1** In the Left viewport, click the viewport Smooth + Highlights label and choose Edged Faces so you can see the knee detail on the pant legs.
- 2** Scale and rotate the thighs so the knee joint falls at the center of the knee detail on the pants.

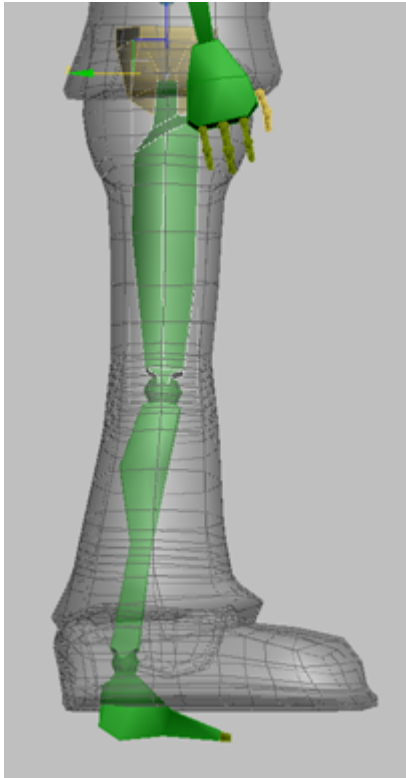

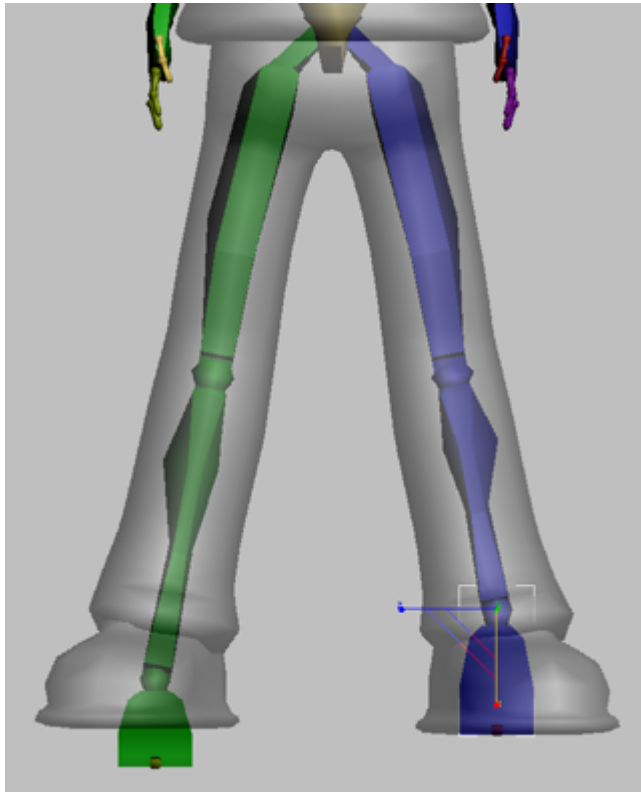

So far you have been posing both legs at the same time. It is possible to pose one leg or arm first, then copy and paste it to the other side.

- 3 In the Front viewport, select one calf. Scale the calf so the ankle joint falls just above the bottom of the pant leg.
- 4 Scale the foot so its bottom reaches the bottom of the mesh foot.



5 Select both the foot and calf you just scaled.

6  In the Copy/Paste rollout, turn on Posture. Click Copy Posture.

7  Click Paste Posture Opposite.

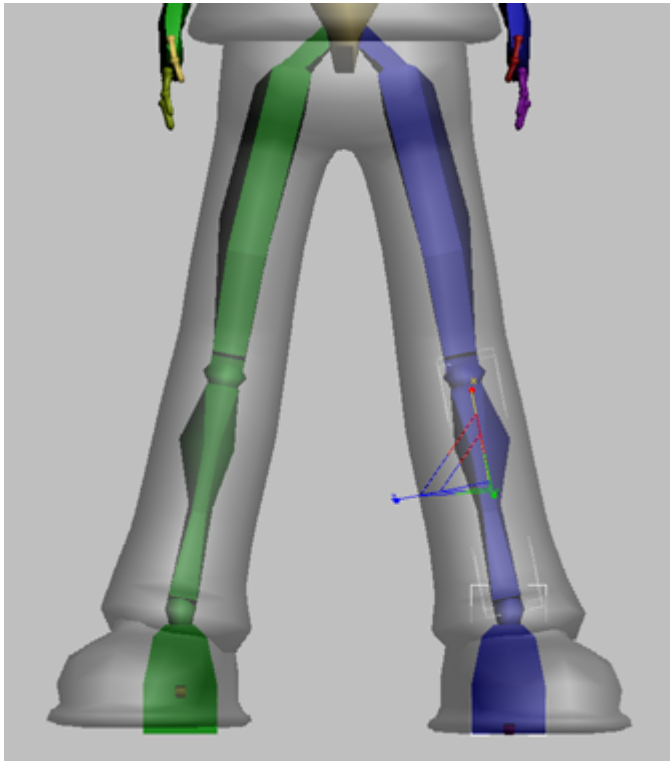

Now the two legs match.

- 8 In the Left viewport, check to see if the ankle joint meets the bottom of the leg. If not, change the Ankle Attach parameter on the Structure rollout to **0.2** or **0.25** to make the ankle match the leg.
- 9 In the Left viewport, rotate the thighs, calves and feet so they align as well as possible with the model.



The file *align_wilson_legs.max* contains the biped posed up to this point.

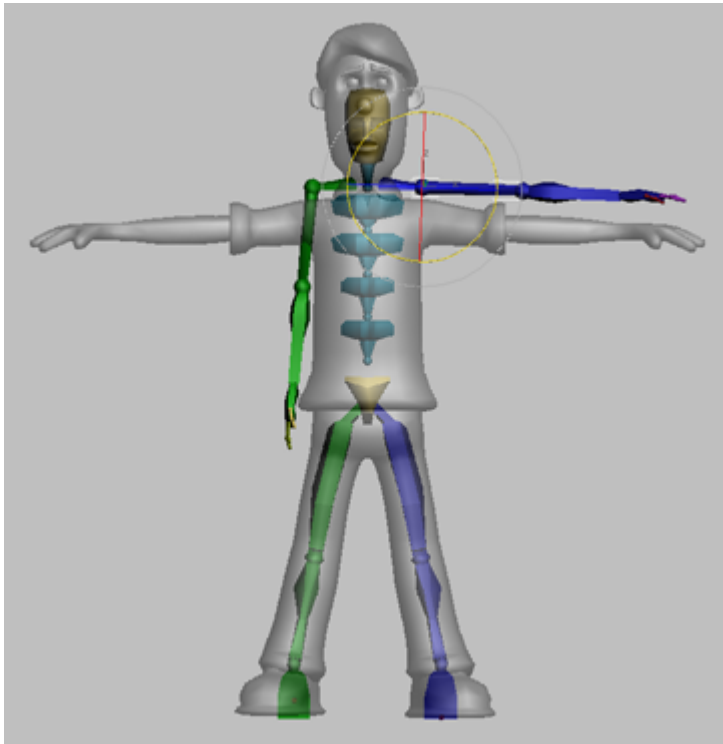

Position the arms and spine:

- 1 Select one of the biped's upper arms.
- 2 In the Front viewport, rotate the upper arm upward to make the arm parallel with the model's arm. Don't be concerned with fitting the arm at this time; simply make it parallel.

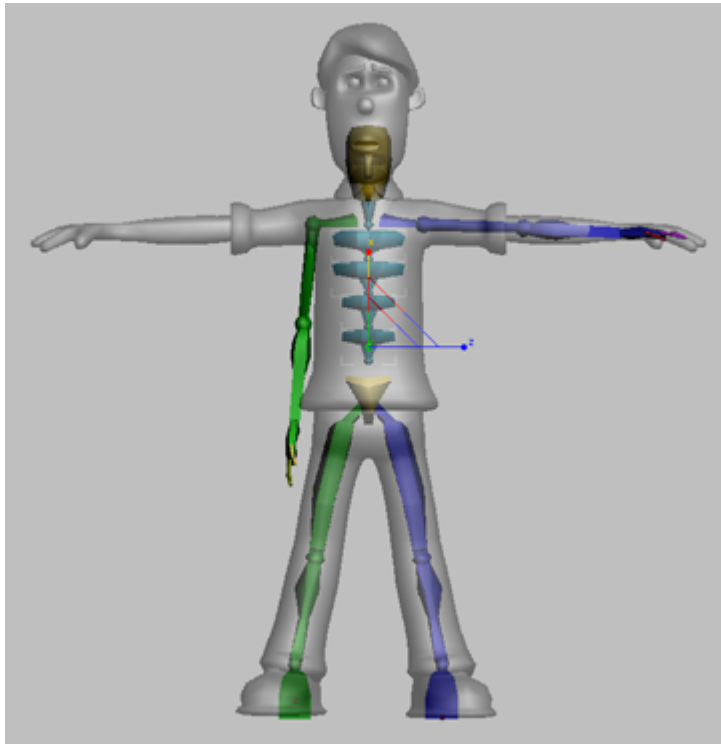

- 3 Select all the spine links and make a selection set called **Biped Spine**.
- 4 In the Front viewport, scale the spine upward or downward to make the upper arm fall into place.



- 5   Select the posed upper arm. In the Copy/Paste rollout, copy and paste this pose to the other side of the biped using Copy Posture and Paste Posture Opposite.
- 6 Use the Biped Spine selection set to select the spine links. In the Left viewport, rotate the spine links slightly so they follow the curvature of the spine. You might need to move the lowest spine link to align the spine correctly.



IMPORTANT Don't rotate the COM when posing the biped. Instead, move the lowest spine link to adjust the position of the spine and upper body.

Now that the spine is curved correctly, the arms might be out of place again.

- 7 Use the named selection set to select the entire spine. In the Front viewport, scale the spine again to make the arms fall into place.
- 8 Check the spine again in the Left viewport to ensure it still follows the shape of the character's torso.
As with the legs and pelvis, you have to work back and forth between the spine and the arms to make both fall correctly inside the mesh.
- 9 In the Front and Left viewports, scale the widths of the spine bones to make them fit the mesh more closely.

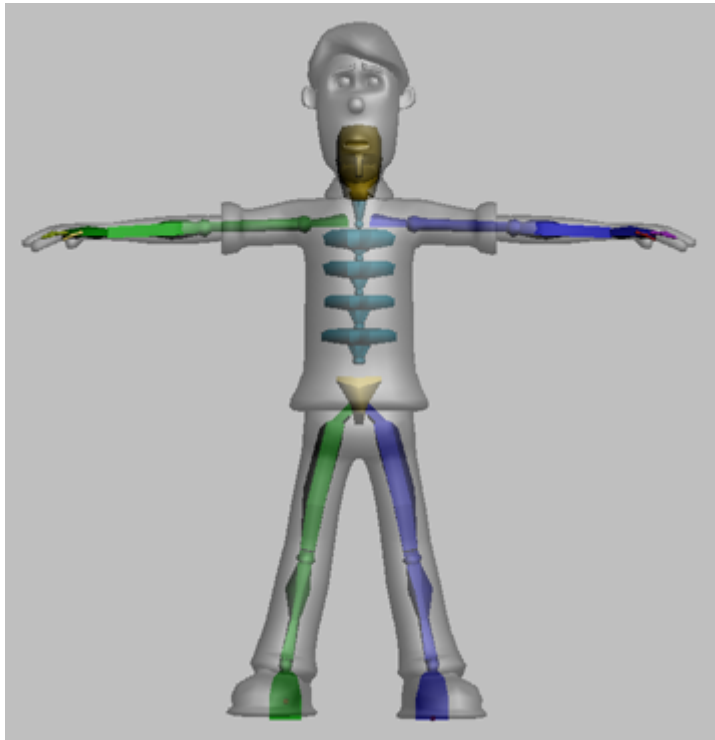

Make each spine bone about two-thirds the size of the mesh. You will have to scale some spine bones more than others.

Pose the arms:

The posing of the arm starts with the clavicle bone, which connects the arm to the torso. Proper scaling of this bone leads to easier skinning of the underarm and shoulder areas later on.

- 1 Select one clavicle. In the Front viewport, scale the clavicle slightly along its X-axis so the biped's shoulder joint falls in the center of the mesh shoulder.

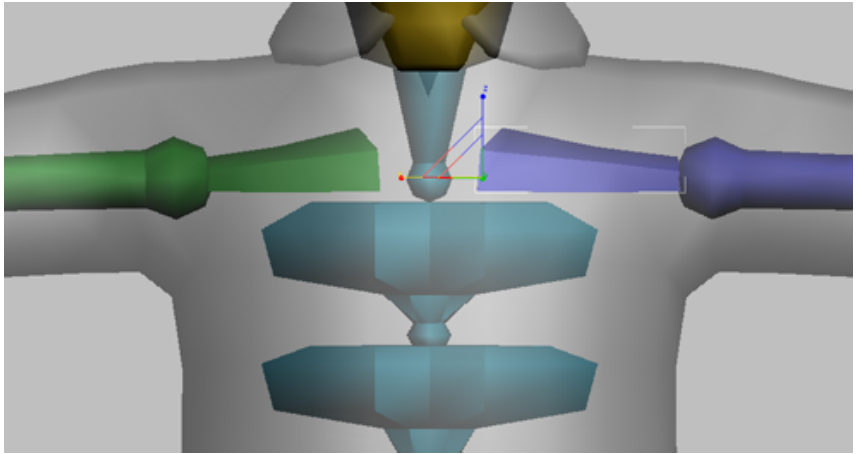

Left (blue) clavicle scaled slightly.

- 2 In Top viewport, work with the upper and lower portions of the same arm. Scale and rotate the arm bones as necessary to fit it to the mesh, taking care to align the biped's elbow and wrist joints with the same joints on the mesh.

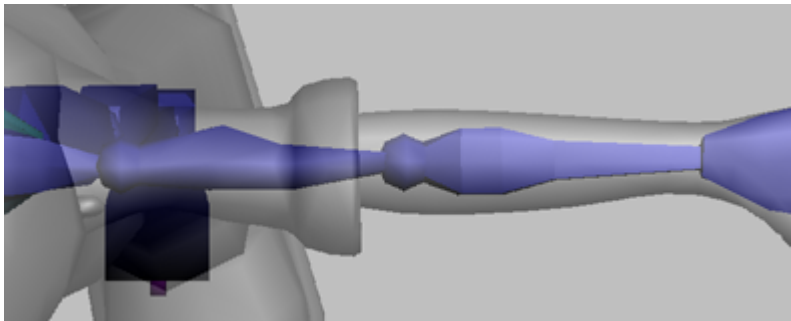

Posed arm in Top viewport

TIP You can move quickly between parent and child bones by pressing Page Up and Page Down on the keyboard.

- 3 In the Front viewport, rotate the arm if necessary to make it go down the center of the mesh.

- 4 Select the clavicle, upper arm, and lower arm, and copy and paste the pose to the opposite side of the biped.
The file *align_wilson_arms.max* contains the biped posed up to this point.

Pose the hands:

Positioning the fingers is the most challenging part of posing the biped. Each finger joint must be moved and rotated separately.

You can rotate each finger and thumb joint, but you can move only the base of each finger and thumb.

You'll have an easier time posing the fingers if you work with the bases of fingers first, moving each one into place before rotating and scaling the finger joints.

- 1 In Top, Front, and Orthographic viewports, zoom in on one of the hands.
- 2 In the Top viewport, rotate the hand slightly if necessary to make it fit the mesh better.
- 3 Scale the biped hand so the palm nearly reaches the point where the pinky finger starts.

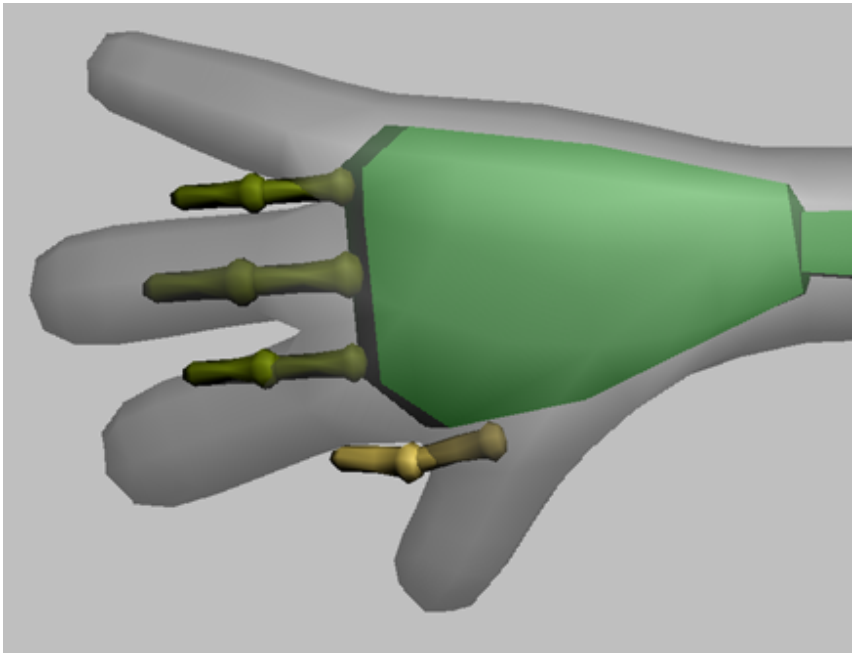

- 4 Check the hand in the Left viewport, and if necessary, rotate it to fit the center of the mesh hand.
- 5 In the Top viewport, move the base of the thumb and each finger to match the base of the corresponding digit on the mesh. Don't concern yourself with the rotation of the fingers just yet.

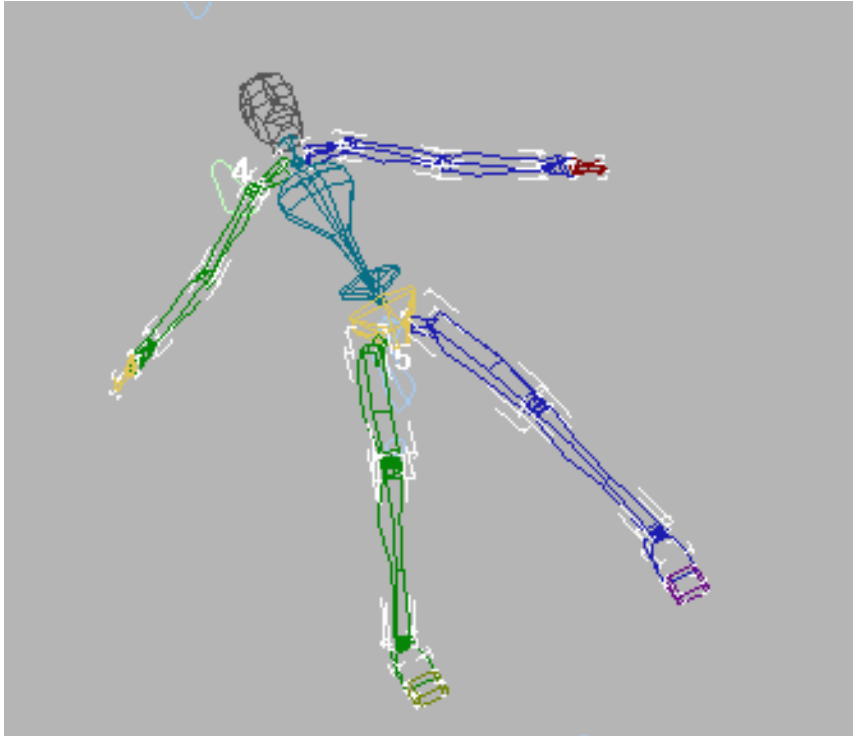

- 6 Rotate base of each finger and the thumb so each goes up the length of the corresponding mesh finger. You might find you have to move the base of the finger again to make it align correctly.

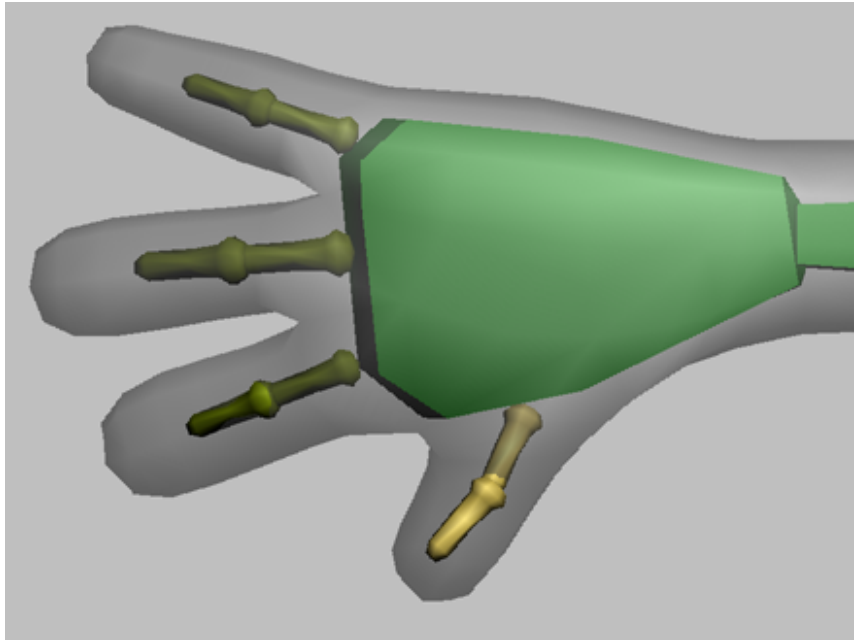

- 7 Scale the lengths of the finger joints so the first goes about halfway down the finger, and the last extends just beyond the mesh fingertip. This will help later on when skinning the character.

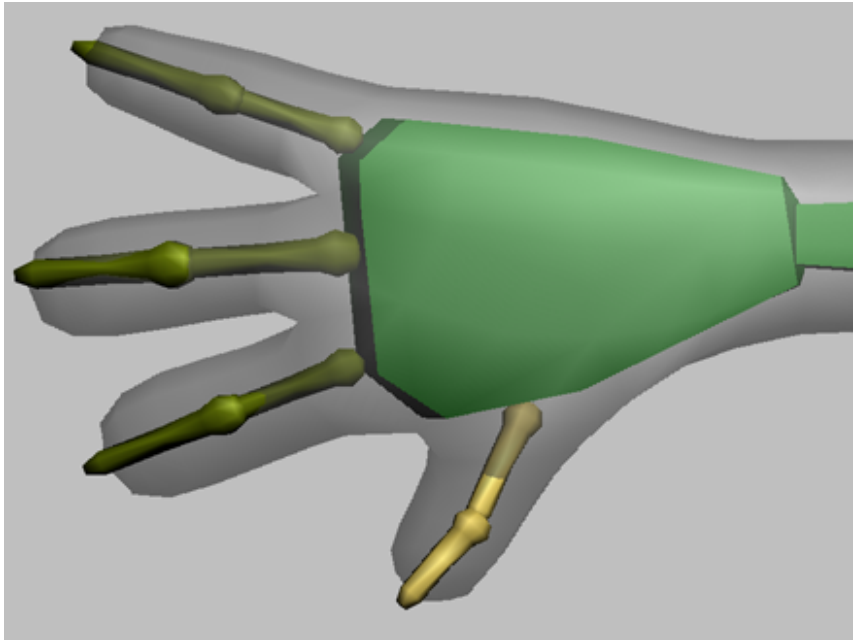

- 8 Using the Top and Front viewports, scale the width and height of each biped finger to about two-thirds the size of the corresponding mesh finger.
- 9 In the Orthographic view, rotate the finger joints to fit the fingers. You can also move each finger base up or down to improve the fit. Look at the hand from various angles to check the fit.

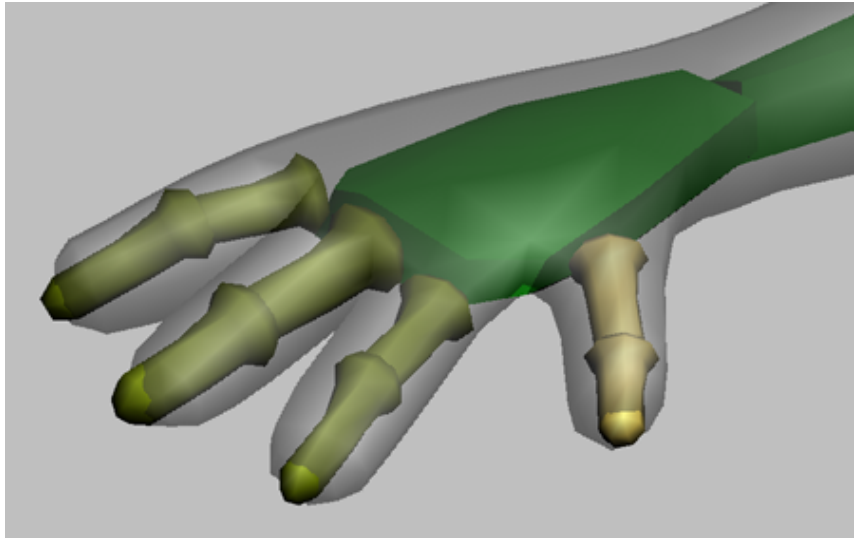

TIP To rotate the view around the hand, select one or more finger bones and use **Orbit Selected** in the Orthographic viewport.

There is no shortcut to posing the hand correctly. You must look at the hand carefully from all angles to ensure that the bones are centered down the mesh fingers and thumb. The thumb bones can be challenging to pose because they rotate differently from the fingers.

- 10** When the hand pose looks good, select all the hand bones, and copy and paste the posture to other hand.
- 11** Check the fit of the bones on the other hand. If necessary, scale or rotate the lower arm to make the fingers fit on the other side.

When a mesh is symmetrical, the hand bones should make an exact fit when pasted to the other side. However, meshes are not always perfectly symmetrical. In addition, if the center of mass is slightly off center, the hand will not fit exactly.

The file *align_wilson_fingers.max* contains the biped posed up to this point.

Pose the head and feet:

- 1** In the Left viewport, rotate and scale the neck link so the biped's chin aligns with Wilson's chin. Do not rotate the head.

- 2 In the Front viewport, scale the head to about half the width of Wilson's head, and to its full height.



- 3 In the Top viewport, rotate the biped's feet to match the angle of Wilson's feet.
- 4 In the Orthographic and Left viewports, scale the foot and toe bones to represent the bulk of the shoe and the toe portion of the shoe. If you have difficulty selecting the toe bone, select the foot and press Page Down.

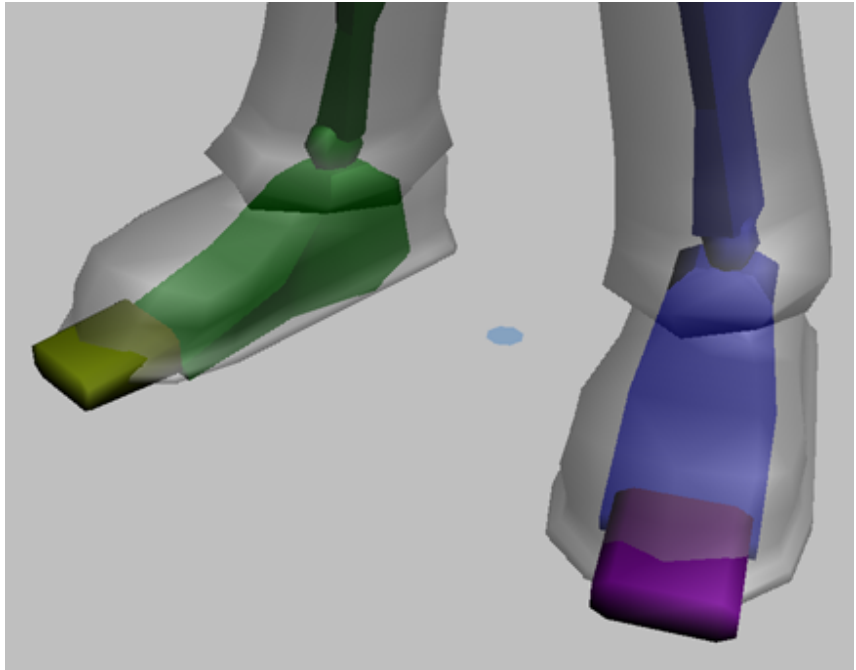

Complete the posing process:

- 1 As necessary, scale biped parts so they are about two-thirds the width of the mesh.
Wilson's pose is now complete.

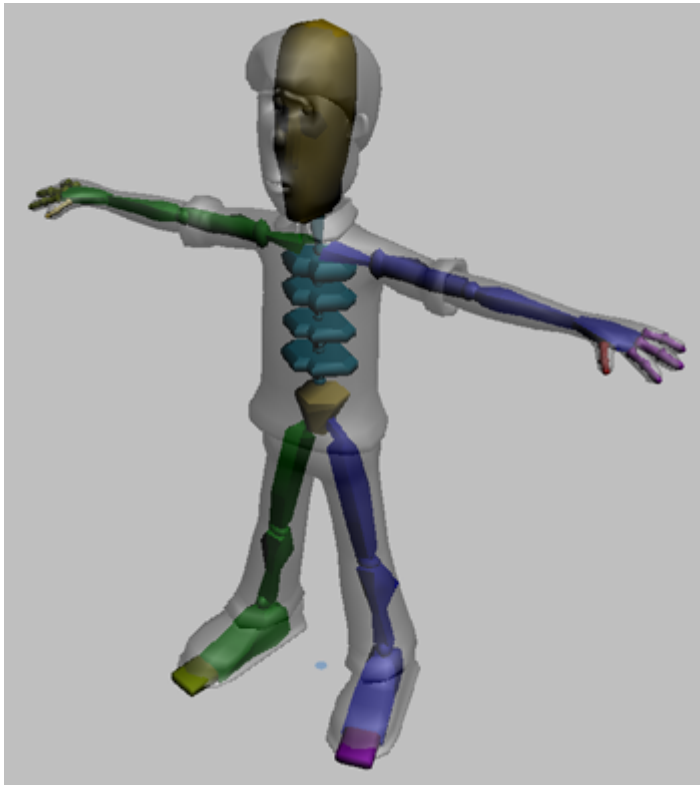

- 2 Select the entire biped, and create a named selection set called **Wilson Biped**.

TIP It's best to wait until you've finished posing the biped to make a biped selection set. If you change parameters on the Structure rollout and add more parts while you're posing, any parts added in this way will not be part of a selection set made at the start of the posing process.

- 3 In the Biped rollout, click the expansion bar to display the Name field.
- 4 Enter **Wilson Biped** in the Name field.

All biped parts are now preceded by the words *Wilson Biped*. Naming the biped in this way greatly assists the process of merging characters into scenes with multiple bipeds.

TIP Giving each of your bipeds a unique name is a good practice. For example, if you decide to merge the character into a scene that contains other bipeds, the merge process won't ask you about duplicate names, and you'll be able to tell them apart easily when selecting objects.

Save the pose:

- 1 Choose the named selection set *Wilson Mesh*, and click Yes on the warning dialog.
- 2 On the Display panel, turn off See-Through.
- 3 Save the scene to the file **my_wilson_pose.max**.
A finished version of the pose can be found in the file *align_wilson_complete.max*.

Applying the Physique Modifier

After the biped is posed to match the character mesh, you apply the Physique modifier to the character mesh and associate it with the biped. The Physique modifier makes it possible to control the mesh with the biped's motion.

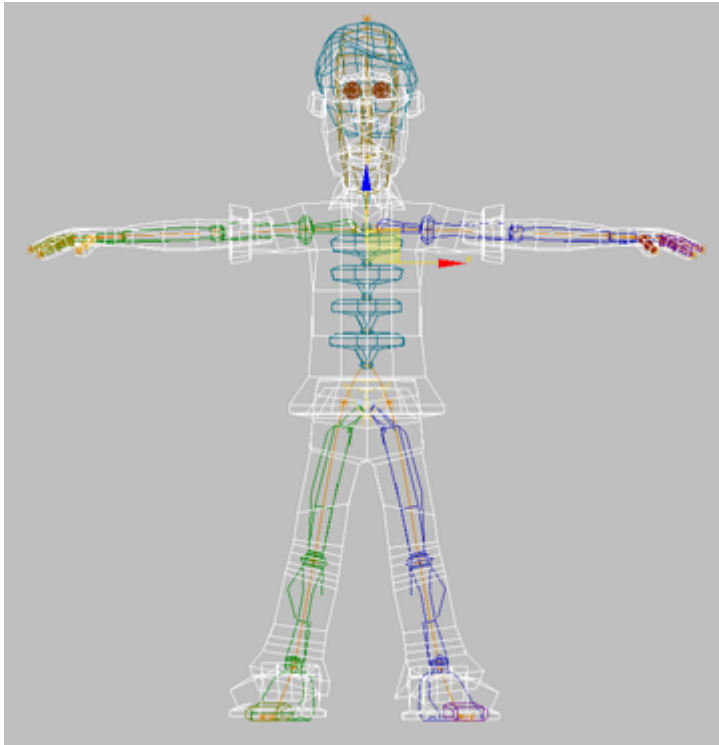

The Physique modifier makes the biped act as a skeleton under a mesh “skin”. Physique assigns each vertex in the mesh to one or more bones in the biped. When the biped bones are animated, appropriate vertices in the mesh will move along with each biped part.

The process of applying and adjusting Physique is called *skinning*.

Set up for this lesson:

- 1 Open the file *my_wilson_pose.max* that you created in the lesson [Aligning the Biped to the Model](#) on page 893. Alternatively, you can open the file *physique_wilson_start.max* from the `\character_animation\physique_basics` folder.

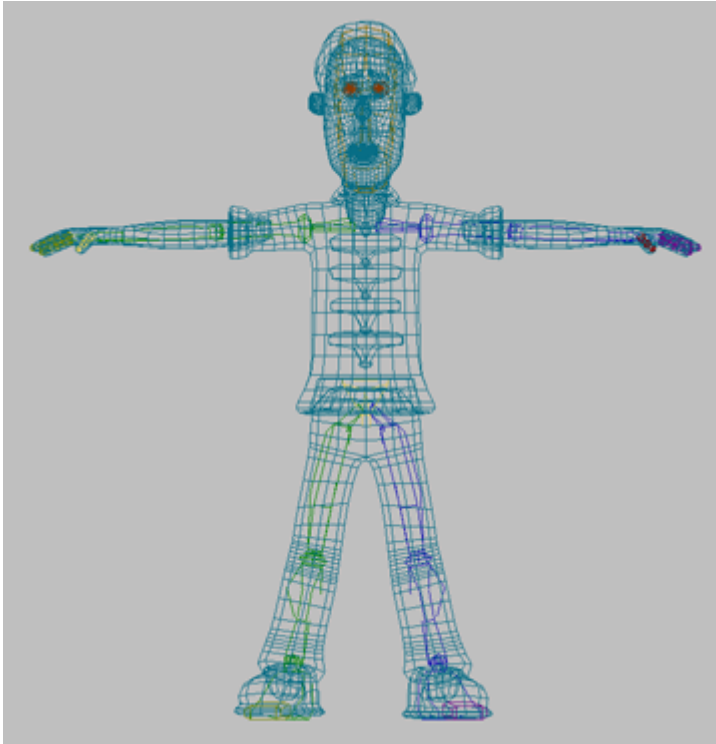

This scene contains the character Wilson and a completely posed biped. You'll apply the Physique modifier to Wilson's head and body, but not his eyes or hair. You'll deal with those objects in a different fashion later on.

In general, the skinning process is easiest when models are as low-poly as possible. Both Wilson's head and body have been smoothed with the MeshSmooth modifier. If you were applying Physique to just one of these objects, you could simply apply it below the MeshSmooth modifier on the modifier stack. Because you'll be applying it to two objects at the same time, you'll need to remove MeshSmooth from both objects and reapply it later.

- 2 Select the object *Wilson Mesh Body*.

- 3  Open the Modify panel.

-  Highlight the MeshSmooth modifier on the modifier stack, and click Remove Modifier From The Stack.
- Select *Wilson Mesh Head* and remove the MeshSmooth modifier from its stack.

Turn on Figure mode:

- Press the H key and select *Wilson Biped*. This selects the biped's center of mass.

-  Open the Motion panel.

-  If Figure mode isn't already on, turn it on.

Apply Physique:

You apply Physique as you would any modifier in 3ds Max.

- Select the objects *Wilson Mesh Body* and *Wilson Mesh Head*.

-  On the Modify panel, choose the Physique modifier from the Modifier List to apply it to the selection.

The Physique modifier appears on the stack in italics to indicate that it is instanced (applied to more than one object at a time).

Attach the biped and mesh:

- In the Front viewport, zoom in on the biped's center of mass.

-  On the Physique rollout, click Attach To Node.

- In the Front viewport, click the biped's center of mass.
The Physique Initialization dialog appears.

- Click Initialize on the dialog.

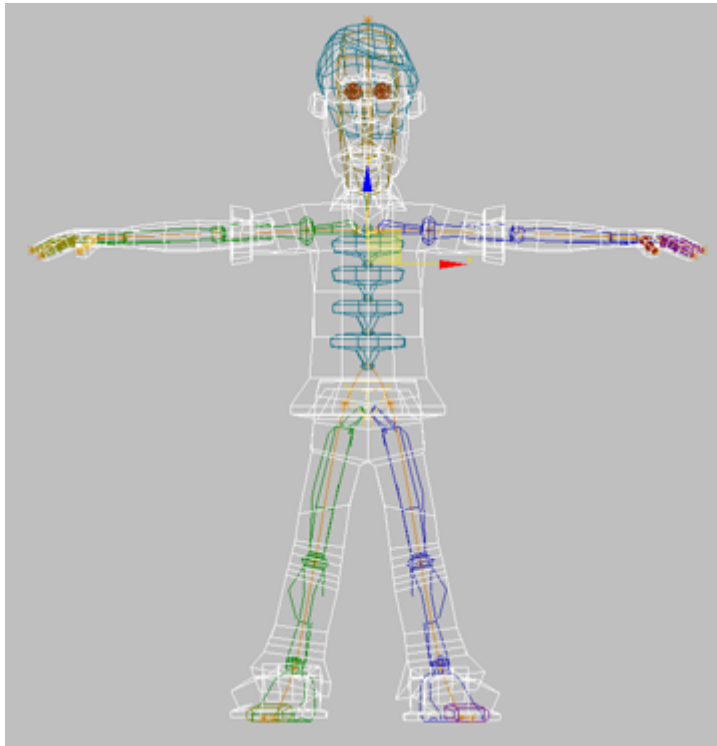

An orange skeleton line appears throughout the mesh. If Physique has been properly applied, the line should extend up through the head, down through all the fingers and through to the ends of the toes

If the orange skeleton line does not go to the ends of the head, fingers, and toes, this means that you picked an object other than the center of mass after clicking Attach To Node. If this happens, click Attach To Node and repeat the last few steps until the orange skeleton line appears correctly.

Create a test animation:

Physique assigns vertices to specific biped bones based on the size of each bone and its proximity to vertices. With careful posing of the biped, the default assignments can be quite accurate, but some adjustment is always needed.

The fastest way to check that vertex assignments is to make a simple animation with the biped and watch how the mesh responds. You'll hide the mesh while animating the biped to minimize the distraction.

- 1 Select the named selection set *Wilson Mesh*, and hide the selected objects.



- 2 Select any part of the biped and go to the Motion panel.



- 3 Turn off Figure mode.

- 4 Expand the Key Info rollout. At frame 0, select the biped's upper arms and thighs, and click Set Key.

- 5 Go to frame 10 and turn on Auto Key.

- 6 Pose the biped with one arm up and one arm down, and with legs split front and back slightly.

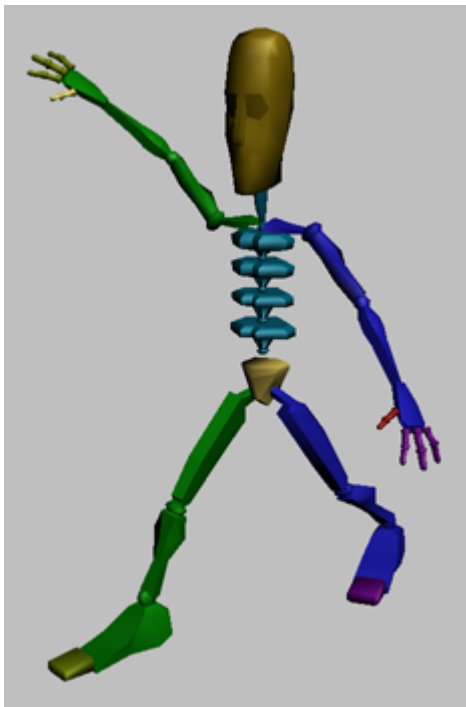

- 7 Scrub the time slider to see the simple animation.

- 8  Turn off Auto Key.

Check the default vertex assignment:

- 1 Go to frame 0.
- 2 Unhide the mesh.
- 3 Scrub the time slider to see how well the mesh responds to the animation.



A few difficulties are immediately apparent:

- Parts of the pant legs are left behind when the legs move.
- Parts of the sleeves are left behind when the arms move.
- Hips are slightly crumpled.

NOTE If you used your own version of the posed biped, your problems with the mesh might be slightly different.

You will fix these problems by adjusting envelopes in the next lesson.

- 4 Save your work in the file **my_physique_wilson.max**.
You'll find a finished version of this lesson in the file *physique_wilson_complete.max*.

Adjusting Envelopes

The bulk of the work in Physique consists of adjusting the size and overlap of envelopes to fine-tune mesh behavior as the character moves.

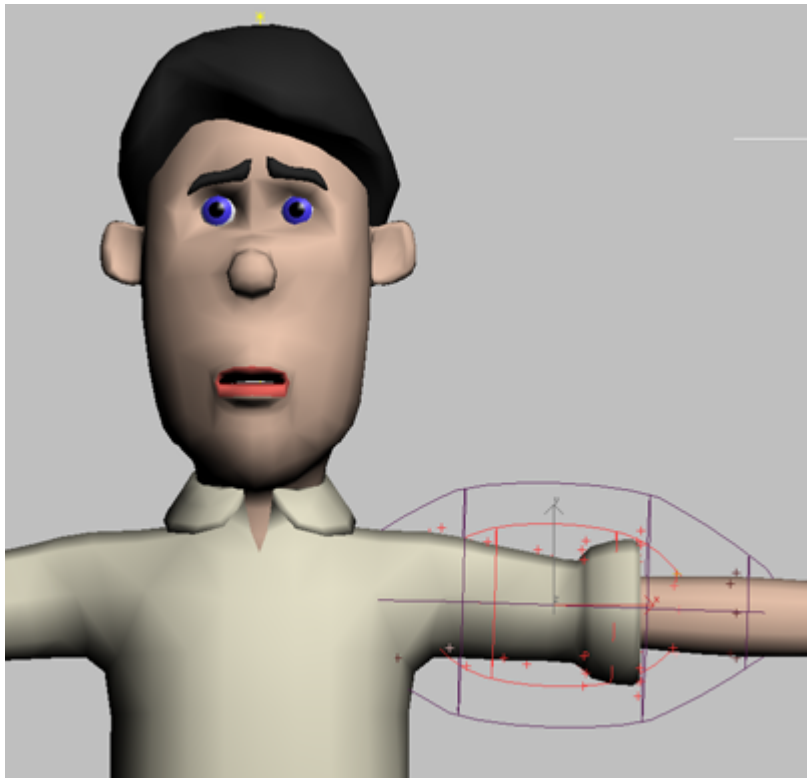

For the best results, each area of the mesh requires some attention.

- Each envelope should encompass its surrounding vertices

- Hip and shoulder areas must be adjusted for smooth deformation when the biped walks or stretches
- The head requires a rigid envelope for minimal deformation

As you adjust the envelopes, inspect the mesh from various angles. A test animation will also reveal different flaws in the mesh as the biped posture changes.

Set up for this lesson:

- 1 Open the file *my_wilson_physique.max* that you created in the lesson [Applying the Physique Modifier](#) on page 920. Alternately, you can load the file *envelopes_wilson_start.max* from the program disc.



This scene contains the character Wilson and a posed biped. MeshSmooth has been removed from the character for the time being. Physique has been applied to the model, but the envelopes haven't been adjusted.

The biped isn't needed for envelope adjustment, so you can hide it for now.

- 2 Select the *Wilson Mesh Body* object.
- 3 Open the Modify panel.
- 4 In the Physique Level Of Detail rollout, turn on Hide Attached Nodes. The biped is hidden, and you have a better view of the mesh.

TIP Turning on Hide Attached Nodes has the same effect as hiding the biped with the controls on the Display panel.

- 5 Scrub the time slider to frame 10.
The biped is animated simply, just enough to show you the main problem areas. The problems with the mesh are:
 - The sleeves don't go with the upper arm
 - The pant legs don't go with the legs as they split
 - The hips do not deform smoothly

If you're using scene you created with the last two lessons, it's possible that your biped pose differs slightly from the file included on the CD, producing different problems with the hands, fingers, legs, or feet.

In this lesson, you'll learn to fix the first two problems listed above. You can apply the same principles to other body parts, such as fingers and toes.

TIP To get a better look at the envelopes and vertices as they change shape, change the Perspective view to an Orthographic view and turn on Edged Faces.

Adjust the arm envelopes:

- 1 In the Front viewport, zoom in on the upper body. The time slider should be at frame 10.
- 2  Go to the Modify panel.
- 3 Expand the Physique modifier listing on the stack, and choose the Envelope sub-object.
The links in the body turn yellow.
- 4 Click the link for the left upper arm.

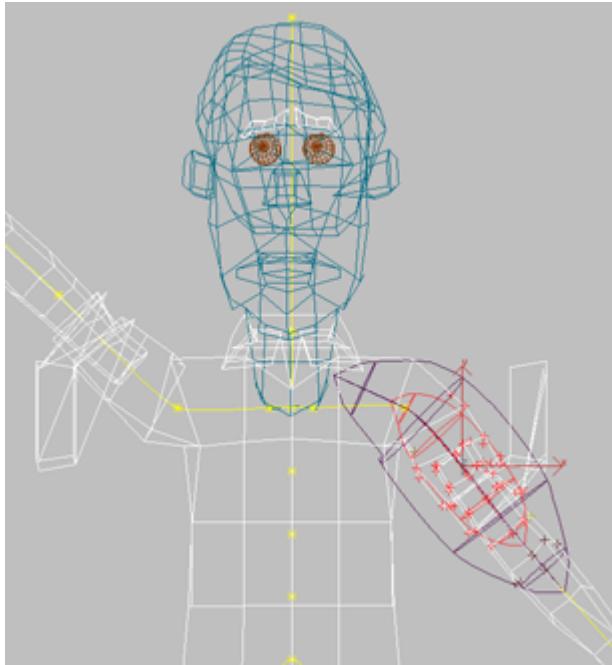

Two envelopes appear around the arm link. The vertices inside the envelopes are influenced by the bone. The inner red envelope indicates the area of most influence. The link's influence decreases until it reaches the purple outer envelope. Vertices outside the envelopes are not affected at all by the bone.

Vertices affected by the currently selected envelope turn various colors to show they are influenced by the envelope.

The radius of each envelope can be changed with the Radial Scale parameter. Increasing the radius enlarges the envelope to encompass more vertices, increasing the number of vertices affected by the bone.

TIP To see the envelopes' influence in color in a shaded viewport, turn on the Shaded option in the Blending Envelopes rollout > Display group.

- 5 In the Blending Envelopes rollout > Envelope Parameters group, increase the Radial Scale parameter until all the vertices in the sleeve pop into place.

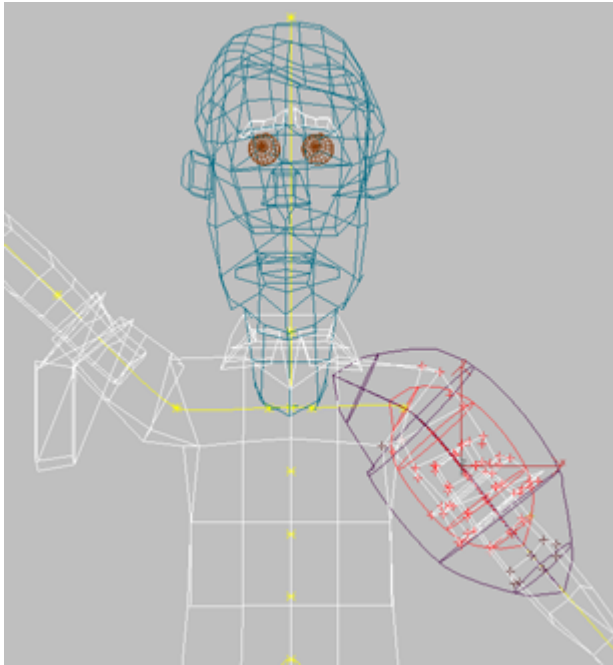

To make the other arm's envelope the same, you can copy and paste the envelope settings.

- 6** In the Edit Commands group, click Copy.
- 7** Select the right upper arm link and click Paste.
The sleeve pops into place for the opposite arm.

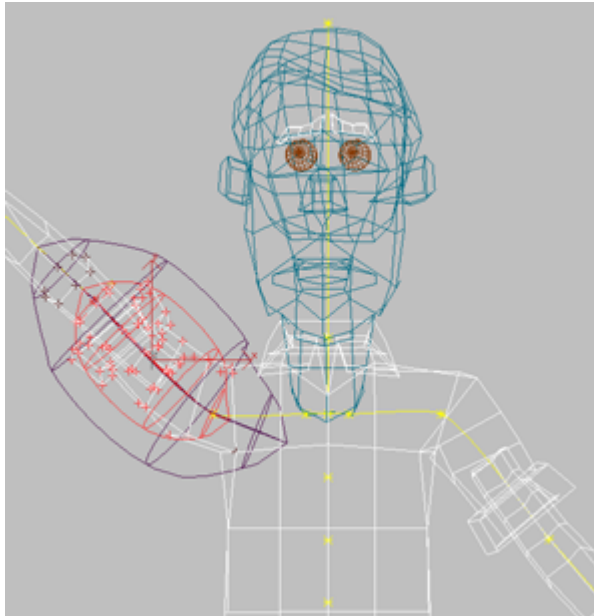

NOTE It is possible that the right arm envelope's Radial Scale will have to be increased slightly to encompass the sleeve on that arm. Even with a symmetrical model, there can be slight differences between the biped pose on each side, causing differences in the initial envelope size and placement.

Adjust the leg envelopes:

The envelopes for the lower legs don't fully encompass the entire pant leg near the ankle.

- 1 Select lower right leg link, and increase the Radial Scale.
When you increase the Radial Scale enough to encompass the entire pant leg, the outer envelope includes some of the vertices on the other leg. You will solve this problem by moving control points.
The process of moving control points is easier if you put the character back into its figure pose.
- 2 In the Display group, turn on Initial Skeletal Pose.
The character jumps back to its figure pose.

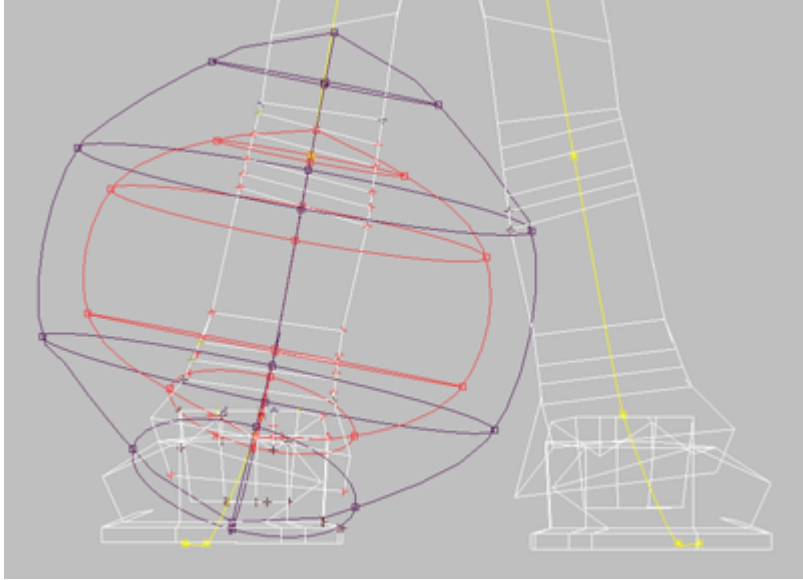

- In the Blending Envelopes rollout > Selection Level group, click the Control Point button.

Control points appear on each envelope.

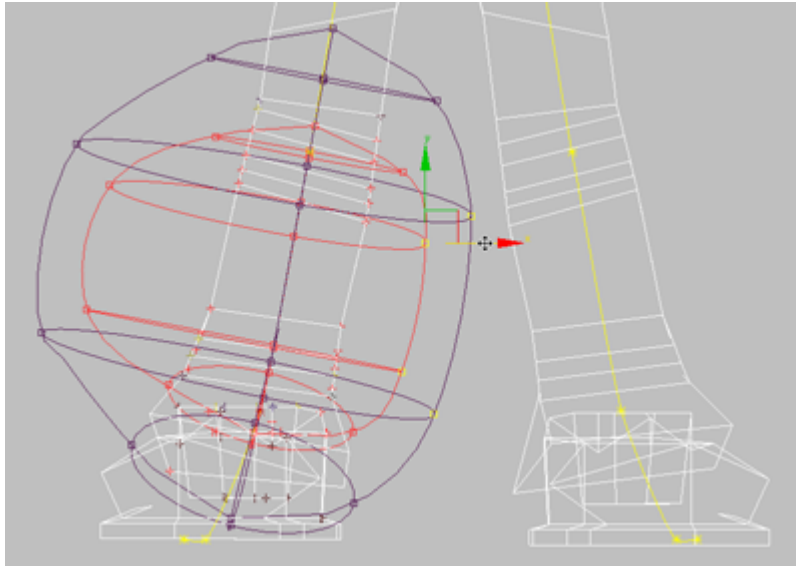

- In the Front viewport, select the control points on the side of the envelope that overlaps the left leg, and move them to the left until the envelopes no longer affect the left leg's vertices.



- 5  In the Blending Envelopes rollout > Selection Level group, click the Link button.
- 6 Select the lower left leg link. Increase its Radial Scale so the envelopes encompass the entire left pant leg.
- 7  Click Control Point.
Control points appear on each envelope.
- 8 Adjust the control points as you did before, so the lower left leg envelopes don't affect the lower right leg's vertices.

Adjust foot envelopes:

- 1 Turn off Initial Skeletal Pose.
- 2  In the Blending Envelopes rollout > Selection Level group, click the Link button.

- 3 Select one of the foot links, and increase the Radial Scale until any parts of the foot that were sticking out are now following along with the foot bone.
- 4 Copy and paste the envelope settings to the other foot, or adjust them manually.

Fine-tune the ankle area:

- 1 Click the Link button, then click the calf link on the left leg.

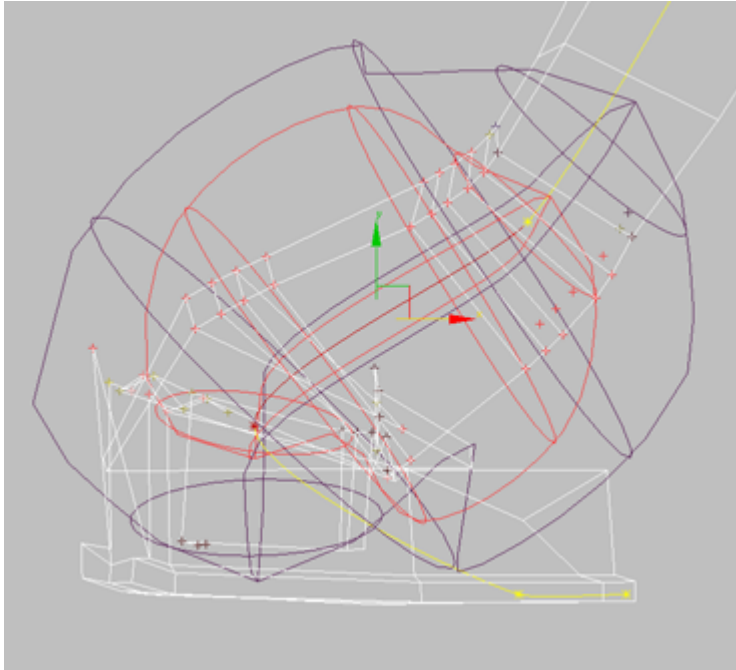

In looking at the pose on frame 10, you can see that parts of the shoe are affected by the calf link, causing spikes to appear on the shoe. You'll fix this problem by adjusting the Child Overlap parameter. This value changes the length of the envelopes in the direction of the child link. In this case, the foot link is the child of the calf link.

- 2 In the Envelope Parameters group, decrease the Child Overlap setting until the calf envelope no longer affects the vertices at the back of the heel.

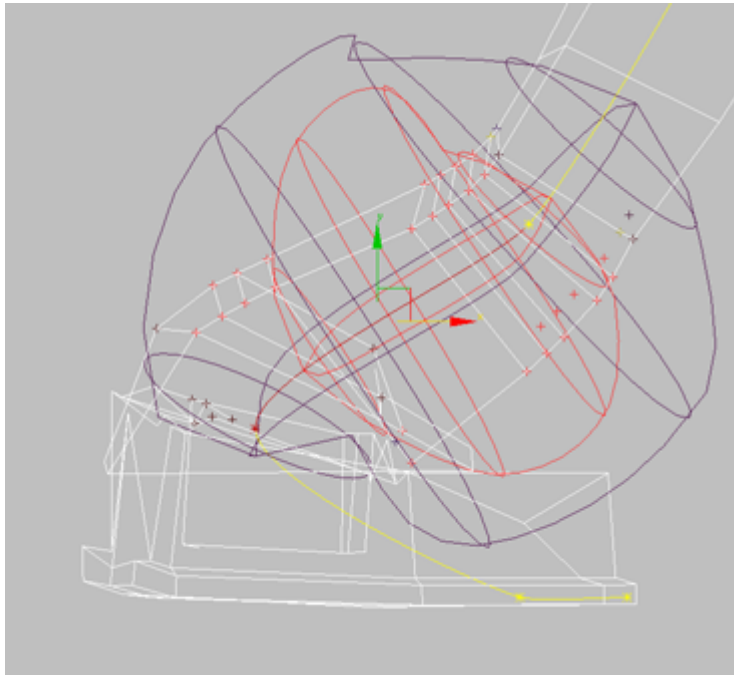

NOTE The Parent Overlap parameter works in the opposite direction, increasing or decreasing the length of the envelopes in the direction of the parent link.

- 3 Copy and paste the envelope settings to the opposite calf link.

Although the hips are not deforming correctly just yet, the arms and legs should now deform properly without vertices being left behind or making unsightly spikes. If any problems remain, fix them by working with the Radial Scale, Parent Overlap, and Child Overlap parameters.

Assign a rigid envelope to the head:

The head is not expected to deform when the biped is animated. To keep it from deforming, you'll assign rigid vertices to it.

- 1 Select the character's head mesh, *Wilson Mesh Head*.

NOTE Because the Physique modifier is instanced on both the mesh and head, it doesn't matter whether the head, the mesh, or both objects are selected when you adjust the head envelopes. Any changes to envelopes will take place on both objects regardless of the current selection. You select the head at this time only because it will be easier to see how vertices are affected when you change the envelopes.

- 2 Access the Envelope sub-object level for the Physique modifier.
- 3 Click the head link to select it.
- 4 In the Active Blending group, turn off Deformable and turn on Rigid. Vertices on the head turn green to indicate they are rigid.
- 5 Adjust the outer envelope so it encompasses the head and a little of the neck, but no more.

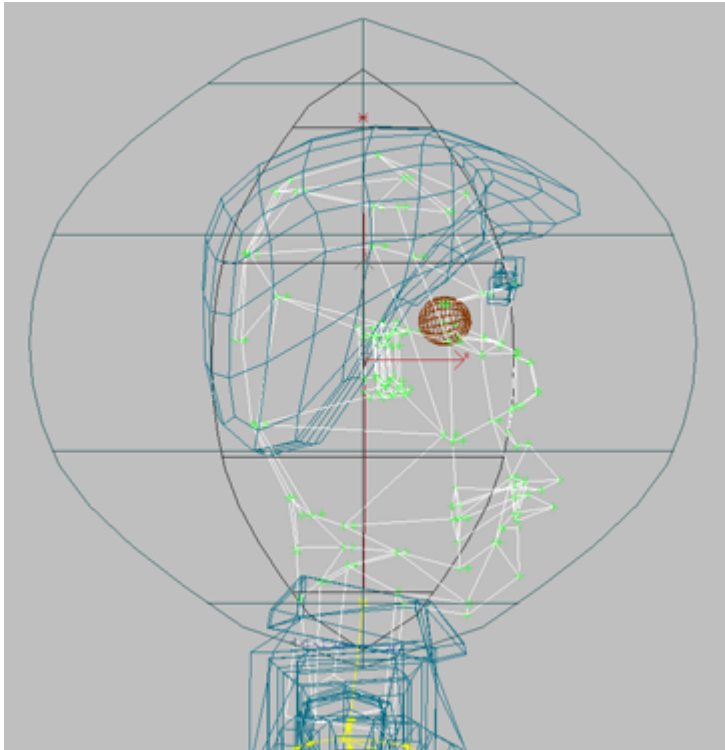

Save your work:

- Save your scene as **my_wilson_envelopes.max**.
A scene with adjusted envelopes can be found in the file *envelopes_wilson_complete.max*.

Summary

This tutorial demonstrated various ways to adjust a Biped skeleton, including using the Knuckles feature for detailed hand animation. It also showed how to skin a skeleton by using the Physique modifier, and how you can adjust Physique envelopes to improve the animation of the skin.

Interacting with Objects

This tutorial shows you how to animate a biped interacting with other objects.

The movement of the biped's hands can control the movement of the second object, or the biped's hands can be constrained to or animated by that other object. There are also lessons on creating the illusion of weight, and using In Place mode.



In this tutorial, you will learn how to:

- Make hands and feet follow objects.
- Simulate lifting and pushing heavy objects.
- Work with props.
- Look at an animated object.

Skill level: Intermediate

Time to complete: 2.5 hours

Making a Hand Follow an Object

In this lesson, you'll make a biped's hand follow an animated object.



When a biped's hand must interact with an object, there are two methods you can use to create the animation:

- Animate the hand, then link the object to the hand with Select And Link, or
- Animate the object, and use IK settings to make the hand follow the object.

The second method has some practical advantages, which are illustrated in this lesson.

Set up for this lesson:

- 1  On the Quick Access toolbar, click the Open File button, navigate to the `\animation\character_animation\interacting_with_objects` folder, and open `ironing_start.max`.

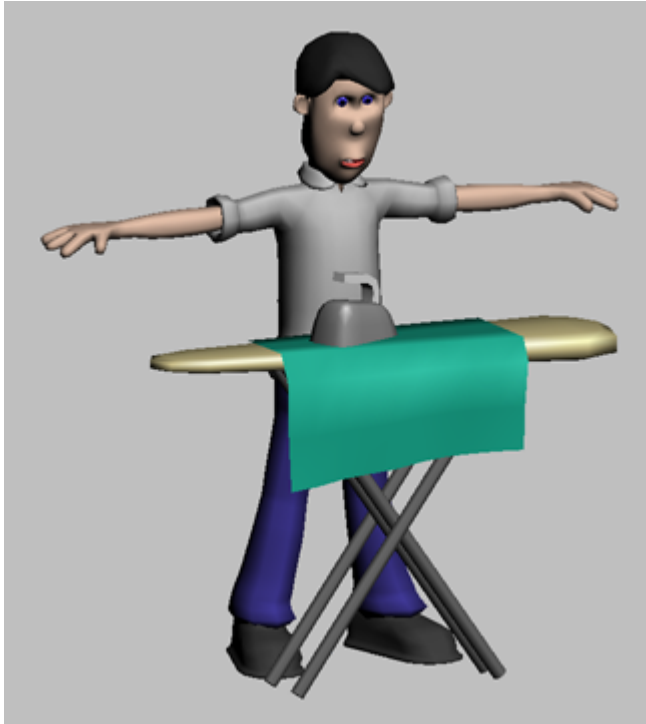

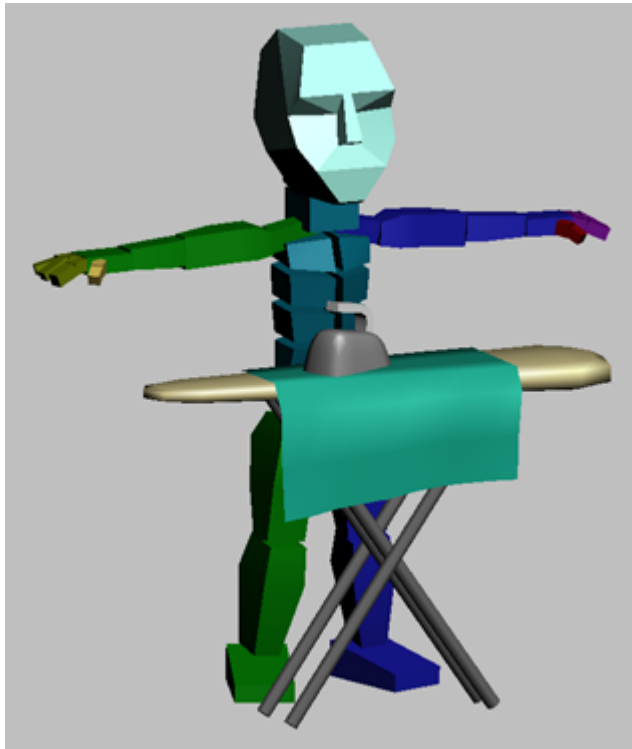

This file features a character named Wilson standing in front of an ironing board.

- 2 Play the animation. The iron is animated to move over the cloth on the ironing board.
This character already has a biped with Physique applied to it. To work with the character, you'll hide the mesh and unhide the biped.
- 3 Choose the named selection set *Wilson Biped*. When the warning dialog appears, click Yes.
The biped appears in the scene.
- 4 Choose the named selection set *Wilson Mesh*.
- 5 On the Display panel, click Hide Selected.
This leaves the biped in the scene without the character mesh.



Pose the hands:

- 1  Go to the Motion panel.
- 2 Go to frame 0.
- 3 Turn on Auto Key.

- 4   Using Select And Move and Select And Rotate, pose the right hand to hold the iron handle. Look at the hand from different angles to ensure it is gripping the handle. Don't be concerned if the fingers pass through the handle slightly.

TIP You can also right-click in a viewport and choose Move or Rotate from the quad menu.



If you have difficulty with this step, open the file *ironing_handpose.max*. This file contains the biped already posed with its right hand on the iron.

- 5 With Auto Key turned on, position the left hand to hold down the fabric.

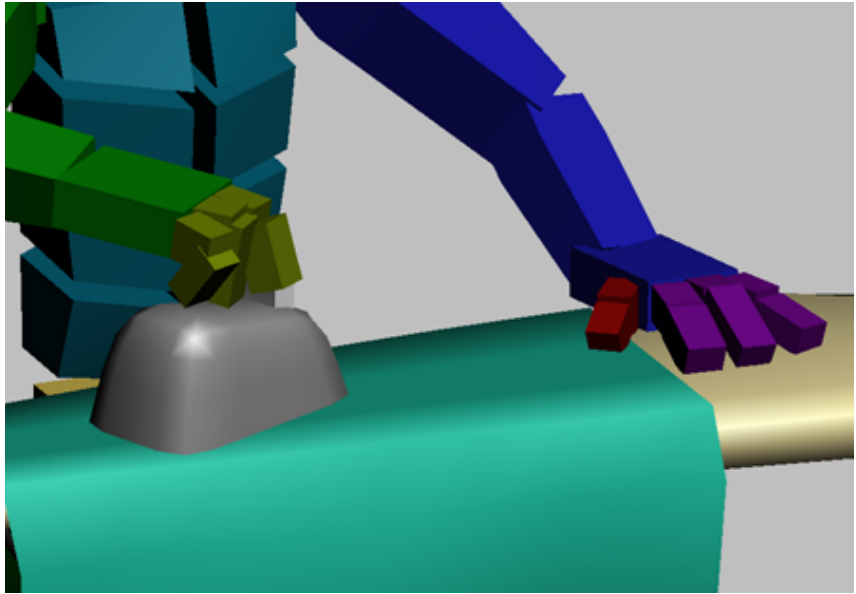

Link the right hand to the iron:

- 1 Select the right hand.
- 2 On the Motion panel > Key Info rollout, expand the IK bar.
- 3  Click Select IK Object, and click the iron.
The object name *Steam Iron* appears to the left of the Select IK Object button.
- 4 Choose the Object option just above the Select IK Object button.
- 5 Change IK Blend to **1.0**.
- 6 Play the animation. The hand follows the iron.

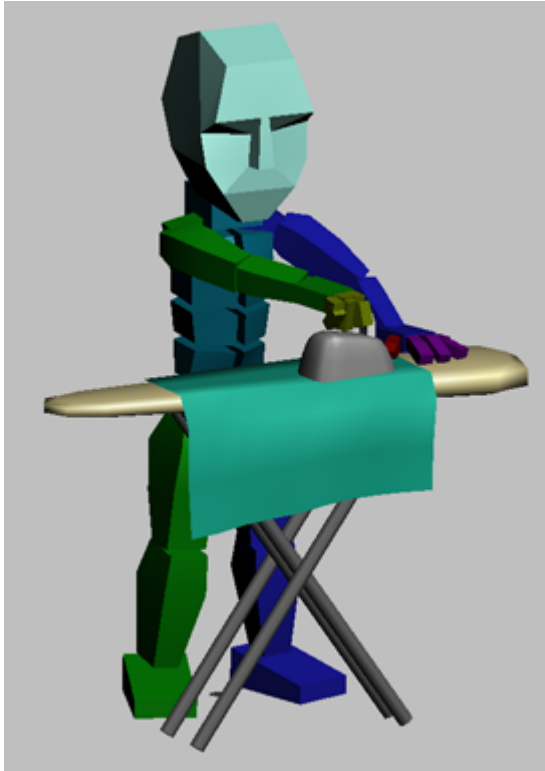

You could have created a similar animation by linking the iron to the hand with Select And Link, then animating the hand. However, this type of animation is limited. For example, if you later bend the biped's spine so he could get a closer look at his ironing, the hand would move with the spine and sink into the ironing board. With IK linking, the hands will stay put when you rotate the spine.

Right now, if you bend the spine, the right hand would stay on the iron but the left hand would move. You can keep the left hand from moving by anchoring it to the ironing board.

Link the left hand to the ironing board:

- 1 Select the left hand.

- 2  Click Select IK Object, and click the ironing board.

The object name *Ironing Board* appears to the left of the Select IK Object button.

- 3 Choose the Object option just above the Select IK Object button.
- 4 Change IK Blend to **1.0**.

Bend the biped over:

- 1 Select all the biped's spine links.
- 2 Make sure you're at frame 0.
- 3  In the Key Info rollout, click Set Key.
- 4 Go to frame 40.
- 5 Make sure that Auto Key is turned on.
- 6 Rotate the biped's spine links so the biped bends slightly forward.



The biped's hands stay in place when the biped bends forward.

- 7 Go to frame 80, and rotate the spine links to make the biped stand up straight again.
- 8 Animate the biped's head every 30-40 frames to make him look at the iron as he works.

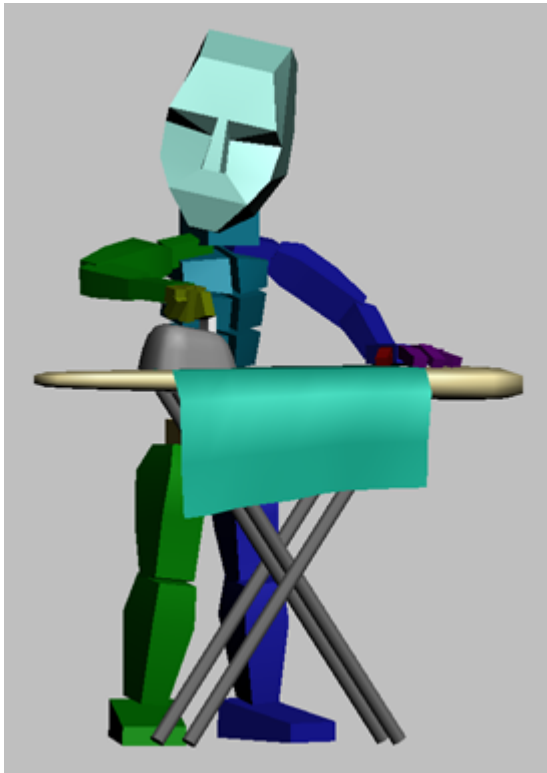

Unhide the character:

- 1 From the Named Selection Sets list, choose *Wilson Mesh*. When the warning dialog appears, click Yes. The character mesh appears in the scene.



- 2 From the Named Selection Sets list, choose *Wilson Biped*.
- 3 Go to the Display panel and click Hide Selected.
The biped is hidden, leaving only the character mesh.

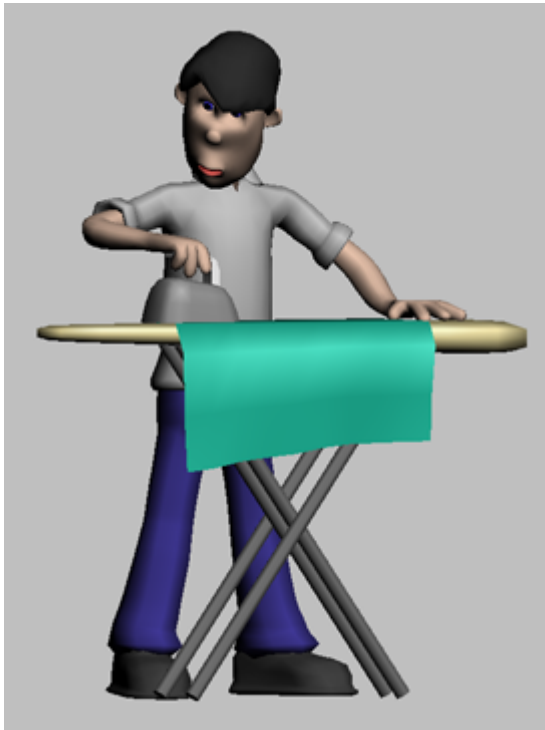

- 4 Play the animation. Wilson irons the cloth and bends over to take a closer look.
- 5 Save your work in the file **my_wilson_ironing.max**.
You can find a completed version of this animation in the file *ironing_complete.max*.

Making Feet Follow Objects

In this lesson, you'll make a character ride a skateboard.

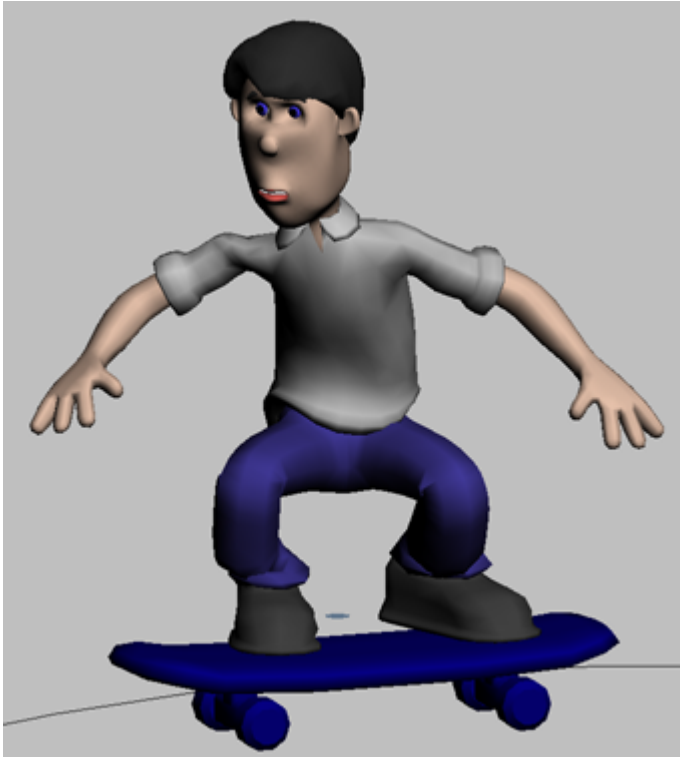

In practice, you could accomplish this animation by linking the skateboard to one of the biped's feet and animating the entire biped. However, this would make it extremely difficult to animate the biped's upper body leaning and dipping as he rides the skateboard. If you did so, every time you moved the biped's foot or leg, the skateboard would skitter and slide unnaturally.



You can't link the biped's feet directly to the skateboard with Select and Link. These body parts are already linked to the legs, and linking them to another object would cause them to become disengaged from the legs and the rest of the body.

Instead, you'll use IK linking to make the biped feet and body follow an animated skateboard. With this method, you can animate the upper body leaning and turning without interfering with the motion of the skateboard. This feature makes it easy to animate a character doing any motion where the feet must remain stuck to the apparatus while the body moves freely, such as pedaling a bicycle or skiing down a slope.

Set up for this lesson:

- 1 Open the file *skating_start.max*.

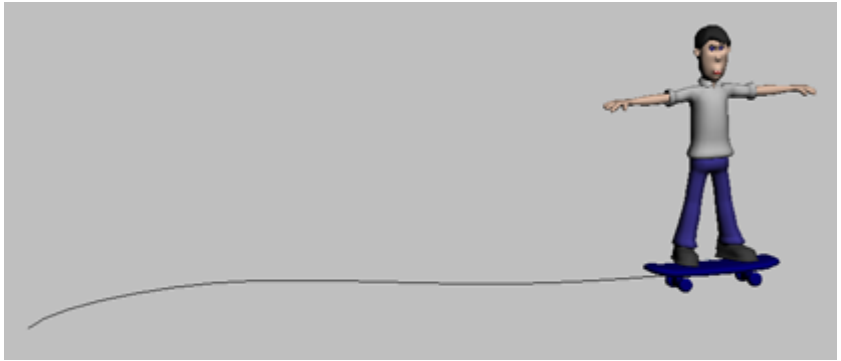

This scene features Wilson on a skateboard.

- 2 Play the animation.
The skateboard follows a path, but Wilson doesn't go with it. You'll work with Wilson's biped to make him ride the skateboard.
- 3 Choose the named selection set *Wilson Mesh*, and hide the selected objects.
- 4 Choose the named selection set *Wilson Biped*, and click Yes on the warning dialog to unhide the biped.

Position the feet:



- 1 Go to the Motion panel.
- 2 Go to frame 0.
- 3 In the Front viewport, zoom in on the feet.
- 4 Turn on Auto Key.
- 5 Rotate each foot so it sits parallel to the top of the skateboard.

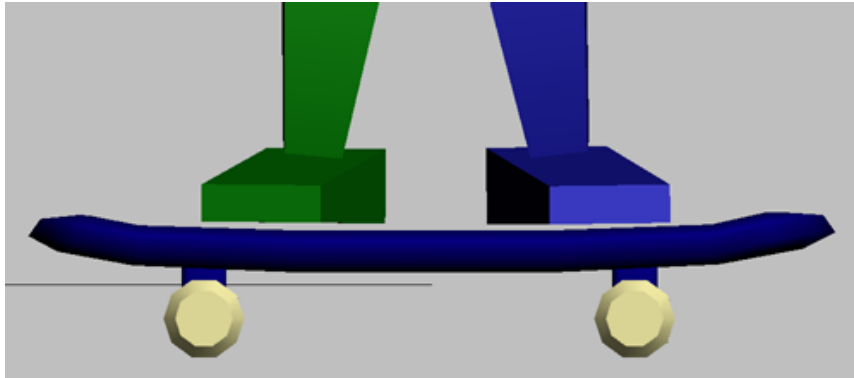

Link the feet to the skateboard:

In order to link the feet to the skateboard, each needs a key set at frame 0. You have already created keys for the feet by posing them on frame 0. If you hadn't, you could use the Set Key button on the Key Info rollout to set keys for each foot/leg.

- 1 Select a foot or leg.
You can select any part of the leg or foot to link it to the skateboard.
- 2 On the Motion panel > Key Info rollout, expand the IK bar.
- 3  Click Select IK Object, and click the top portion of the skateboard.
The object name *Skateboard Top* appears to the left of the Select IK Object button.
- 4 Choose the Object option just above the Select IK Object button.
- 5 Change IK Blend to **1.0**.
- 6 Select any part of the other foot or leg, and repeat these steps to link it to the skateboard.
- 7 Play the animation.

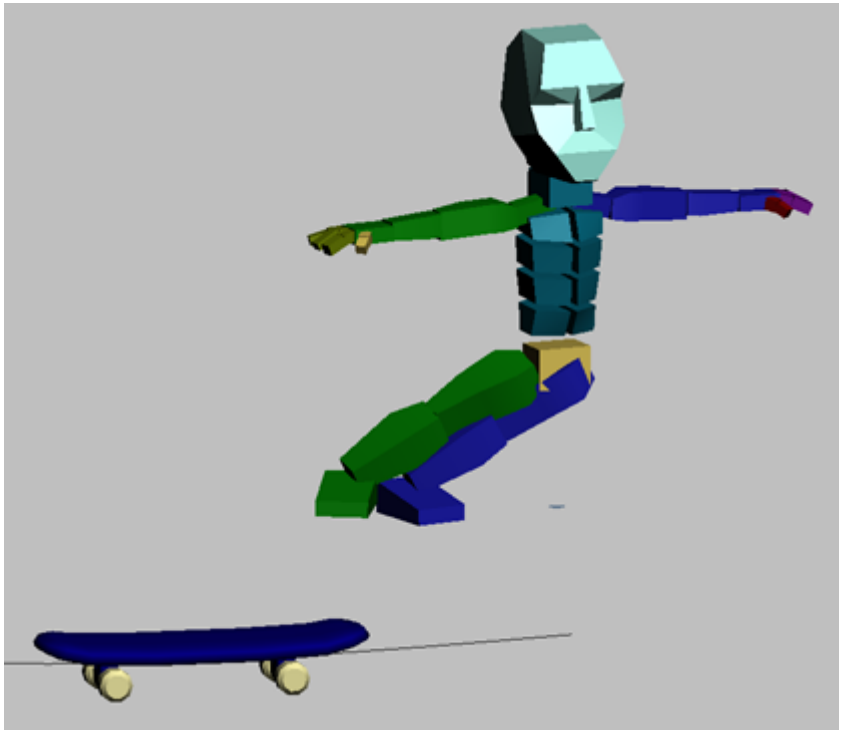

The biped tries to follow the skateboard, but he's not very successful. The legs extend as much as they can, but the skateboard moves away and the biped's center of mass stays in the same place.

To make the entire body go along with the skateboard, you'll link the center of mass to it.

Link the COM to the skateboard:

The center of mass object (COM) is the only object in the biped that isn't linked to other objects in the biped. It can be linked to any object with Select And Link to make the entire body follow along with the object.

- 1 Select the center of mass object, named *Wilson Biped*.



- 2 On the main toolbar, click Select And Link.
- 3 Link the center of mass to the skateboard.

4 Play the animation.

The entire biped moves with the skateboard.

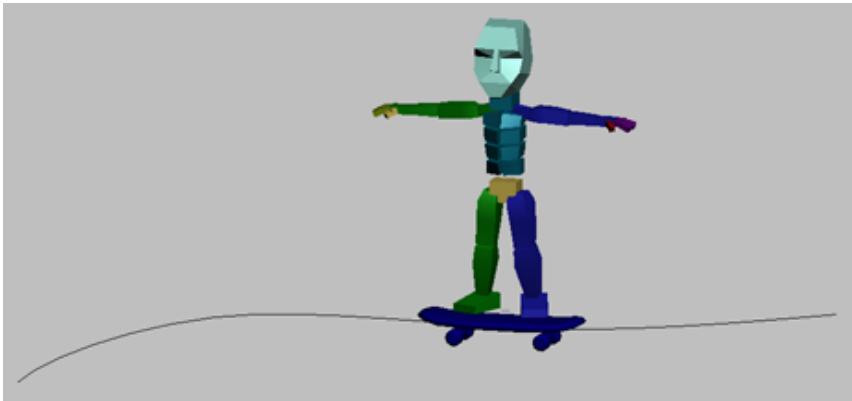

Animate the upper body:

The linking method you've used allows you to animate the upper body freely without interfering with the skateboard motion.

- 1** Go to frame 0.
- 2** Make sure that Auto Key is turned on.
- 3** Pose the biped in a crouch, as if ready to turn a corner on the skateboard. Move the center of mass downward to bend the biped's knees, and move it horizontally to shift the biped's weight. Rotate the spine to make the biped lean forward, and pose the head and arms.



TIP To rotate the legs outward, rotate the calf and not the thigh. This will rotate the legs while keeping the feet in place.

- 4 Go to frame 60 and change the pose slightly. You can move the center of mass to shift the biped's weight, turn his head, or move his arms to different positions.
- 5 On frame 120, change the pose again.
- 6 Play the animation.
The biped rides the skateboard, leaning and dipping to keep his balance.

See the animation on the character mesh:

- 1 Select the named selection set *Wilson Mesh*, and click Yes to unhide the mesh.
- 2 Select the named selection set *Wilson Biped*, and hide the selection.

3 Play the animation. Cowabunga!



You can see a finished version of this animation in the file *skating_complete.max*.

Creating the Illusion of Weight

There are two techniques for giving the illusion of weight to a biped object in an animation. Both affect the biped center of mass.

The first technique uses Balance Factor, which moves the center of mass. Balance Factor is available on the Body Horizontal track. This technique creates the illusion of lifting a heavy object. It lets you keyframe the center of mass moving in and out of the body.

The second technique uses Figure mode to turn on Rubber Band; you then move the center of mass in front of or behind the body. This technique creates

the illusion of the biped pushing or dragging a heavy object. You can't keyframe the center of mass with this technique; instead, you set it for the entire animation.

Lifting Heavy Objects

Set up for this part of the lesson:

- 1 Open *balancefactor_start.max*.

Two bipeds have planted keys set on their feet, with the pivot points set at their toes.

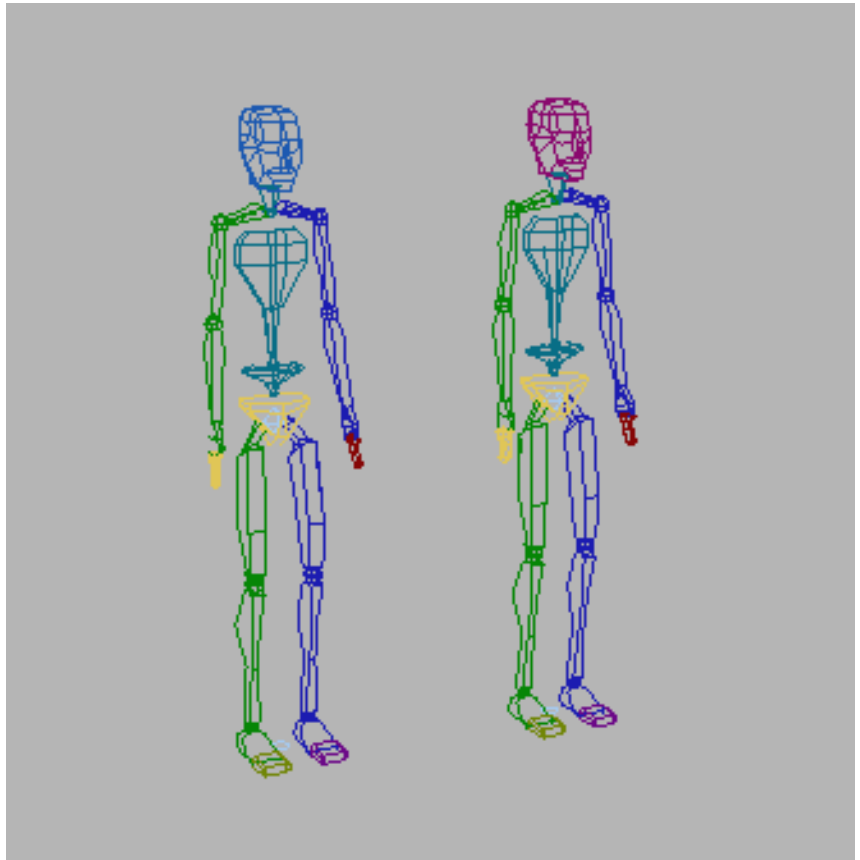

- 2 Select any part of the biped on the left, and then open the Motion panel.

Use Balance Factor:



- 1 On the Track Selection rollout, click the Body Horizontal button.
- 2 In the Key Info rollout, expand the Body expansion bar so you can see the Body parameters. Then set Balance Factor to **0**.

The Balance Factor is available because this file contains a keyframe on the Body Horizontal track at frame 0.

TIP Many parameter settings will not be available unless you have a key set on a particular track. If a parameter is unavailable, click Set Key in Key Info rollout and see if it becomes available.

- 3  Move to frame 15, then turn on Auto Key mode.
- 4 Select *Bip01 Spine* object (the first, or lowest, spine object).
- 5 Use Orbit to see the biped from the side.
- 6 Rotate the spine about the Z-axis.
Notice that the upper body rotates, while the legs stay firmly planted.

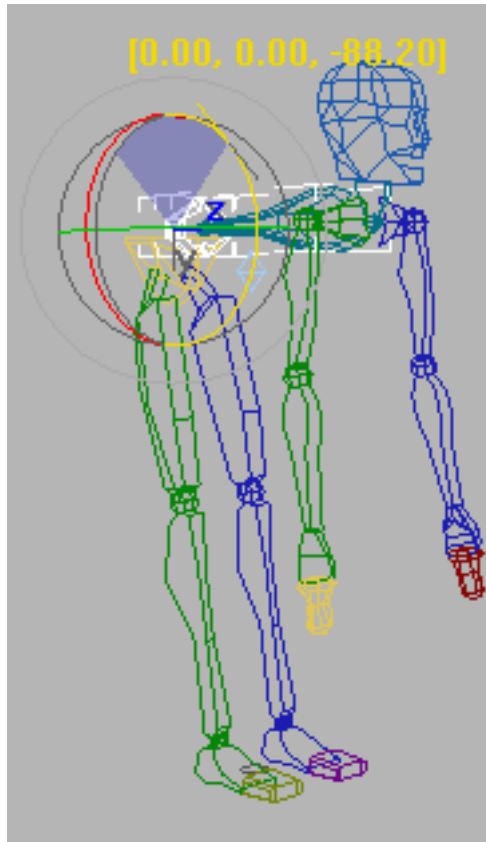

Only the upper body rotates.

Animate the Balance Factor:

- 1 Select any part of the other biped.
- 2 In the Track Selection rollout, select Body Horizontal.
- 3 In Key Info rollout, click Set Key.
Now Balance Factor is available.
- 4 Change Balance Factor to 2.
- 5 Select *Bip02 Spine*. Rotate this spine.

This time the hips move back as the torso rotates forward. If you rotate the torso enough, the feet move off the floor.

Notice also that the center of mass is now in front of the body.

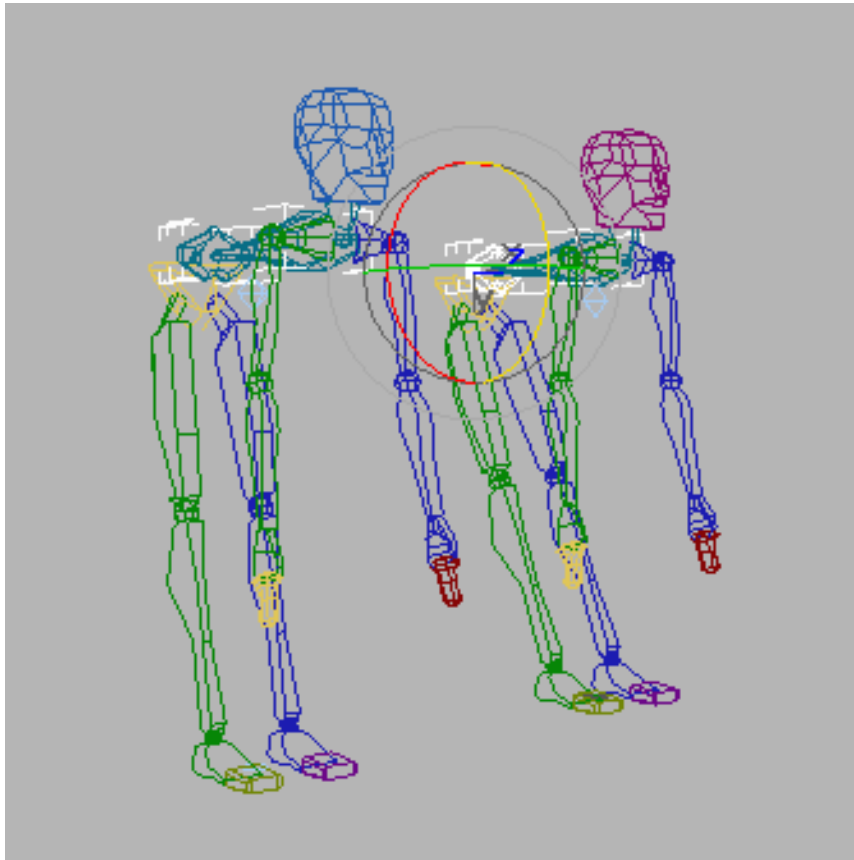

Hips move back, torso rotates forward.

- 6 Move to frame 0, and select Body Vertical in the Track Selection rollout. In the viewport, use the Transform gizmo to move the center of mass down, so the knees are bent.
- 7 At frame 15, also move the center of mass down so that the knees stay bent.
- 8 Use the time slider to view the motion. Notice that you no longer have the original standing poses at frame 0.

- 9 Go to frame 0. Rotate *Bip02 Spine* so the standing pose is re-established. Adjust the COM so the knees are not bent.

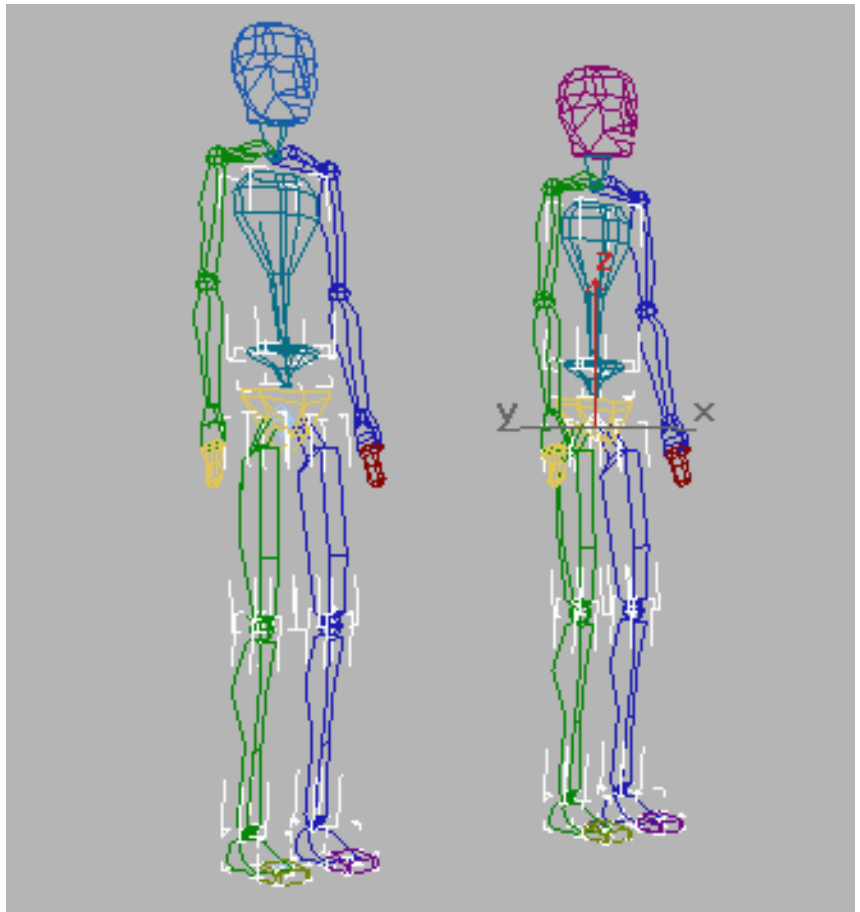

- 10 At frame 23, move the COM way down so the chest goes right through the leg (this will look wrong, but don't worry). Then rotate the *Bip02 Spine* so the knees almost touch the chest.

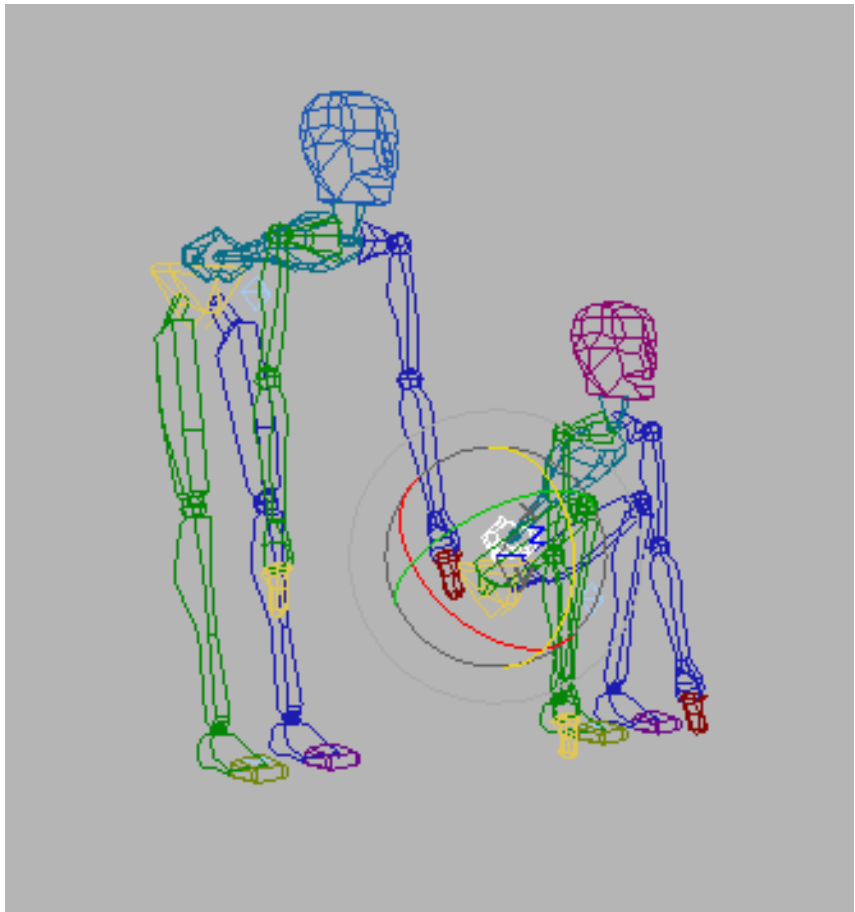

TIP There's nothing that prevents biped body parts from intersecting. Check your animation for these intersections visually and correct by adjusting keyframes.

- 11 At frame 30, move the center of mass so the biped starts to lift the imaginary object using its legs, rather than its back.

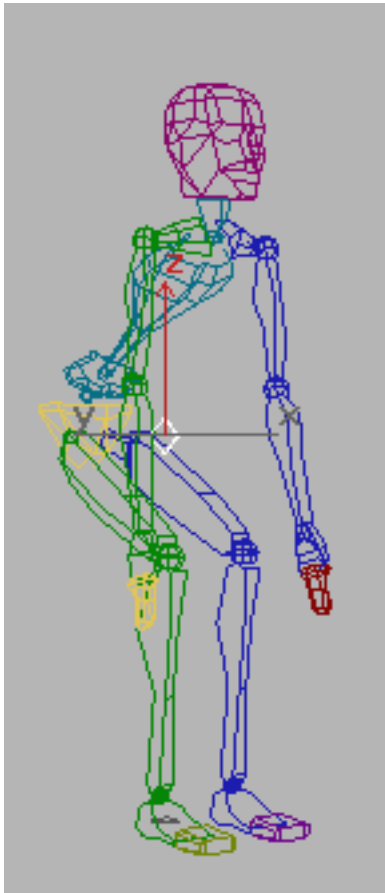

- 12 At frame 38, in the Track Selection rollout, click the Body Horizontal button.
- 13 On the Key Info rollout, click Set Key.
- 14 Change the Balance Factor to **1**.
The center of mass moves back closer to the biped.
- 15 Select and rotate the spine.

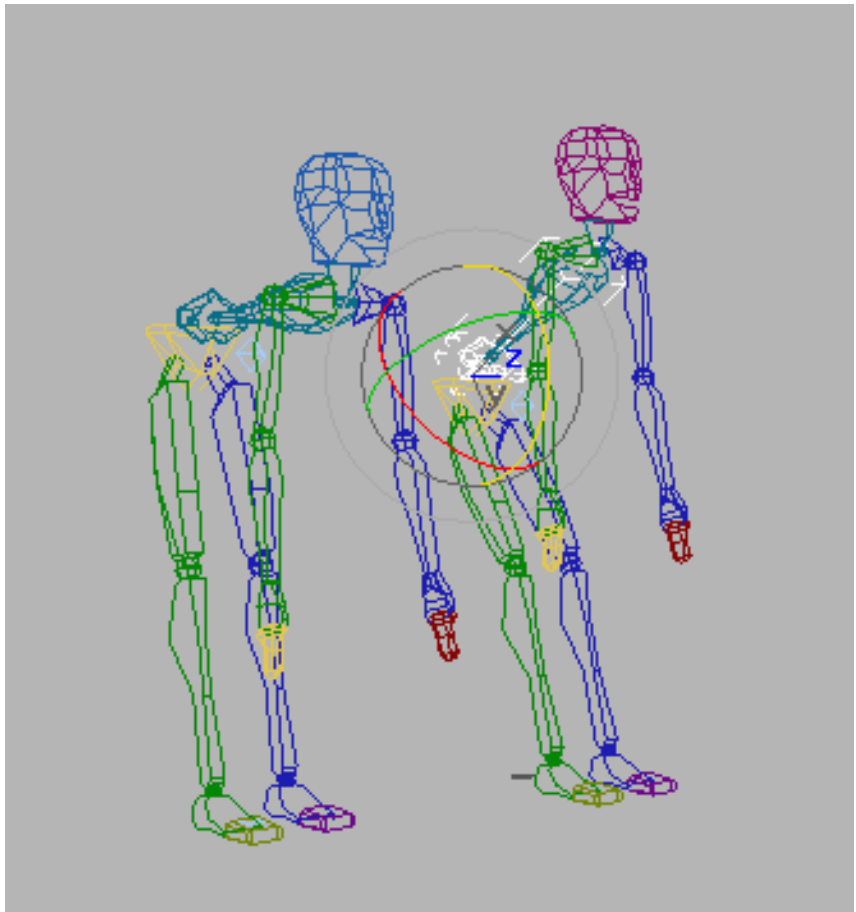

- 16 At frame 45, rotate the spine more.
- 17 Move the center of mass so the biped stands up straight. Now the center of mass is back inside the body.

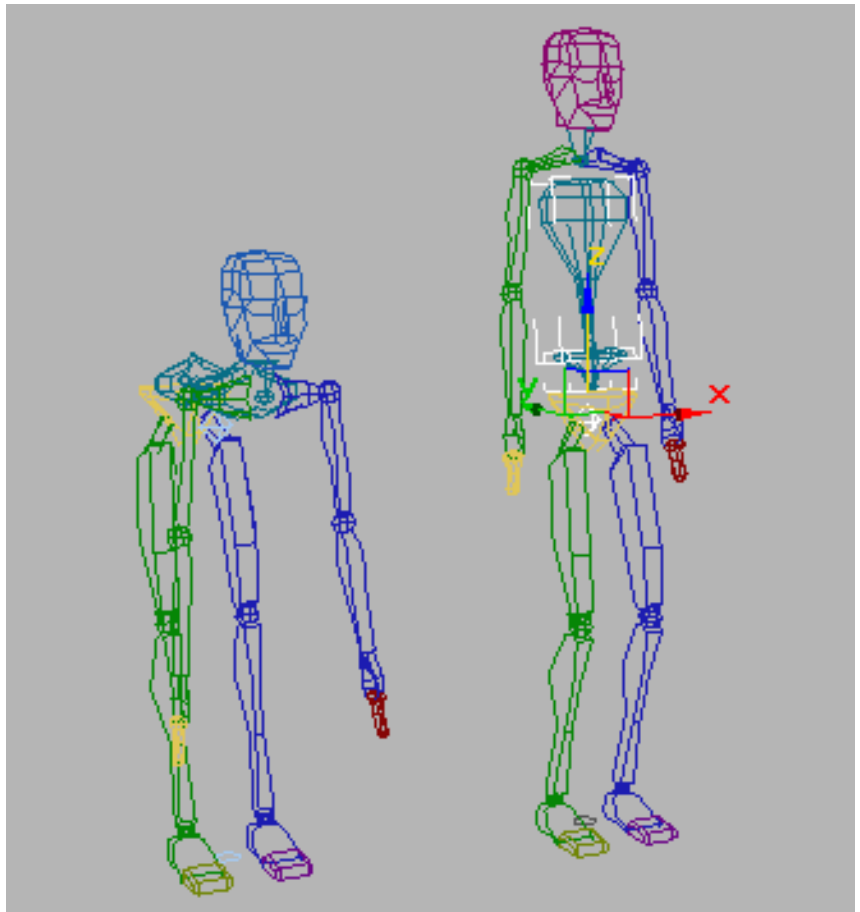

- 18** Move the time slider back and forth to view the animation.
Watch how the center of mass moves outside the biped, then back again.
The biped appears to be lifting something heavy because of the positioning of the knees and spine.
- 19** For extra credit, finish the animation of the other biped. Save your work as **my_balancefactor_final.max**, or open *balancefactor_final.max* for comparison.

Pushing Heavy Objects

Set up for this part of the lesson:

- 1 Open *pushbox_start.max*.
- 2 Play the animation.

The biped is pushing a box along the floor. Notice that the center of mass is behind the biped.

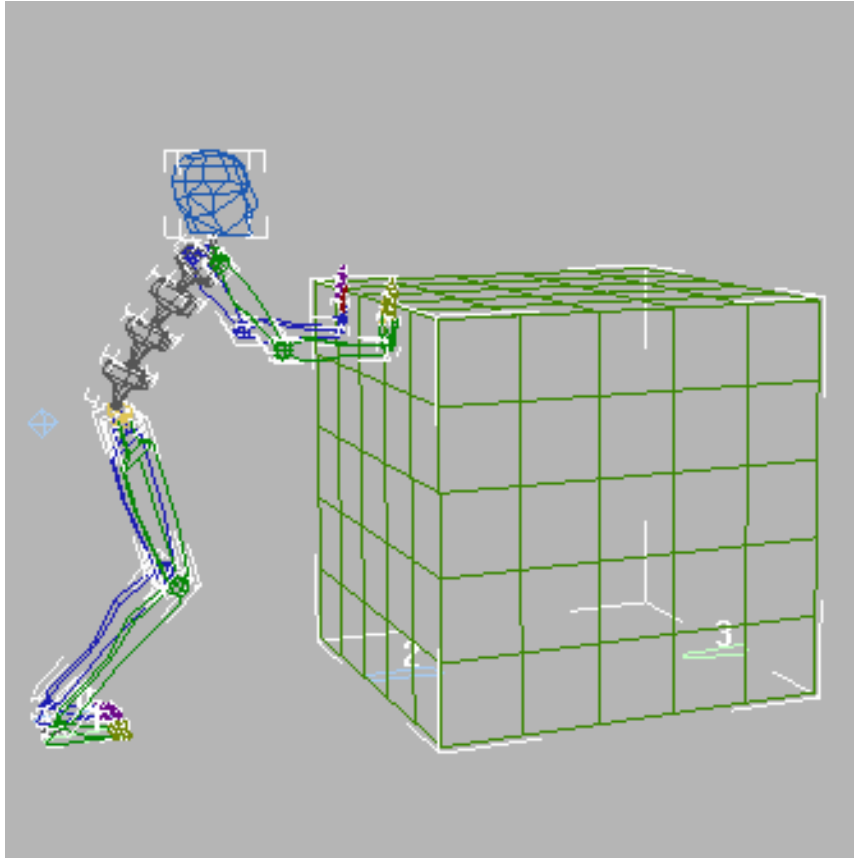



Adjust the center of mass with Rubber Band:

- 1 Select any part of the biped.
- 2 In the Motion panel, in the Biped rollout, turn on Figure mode.

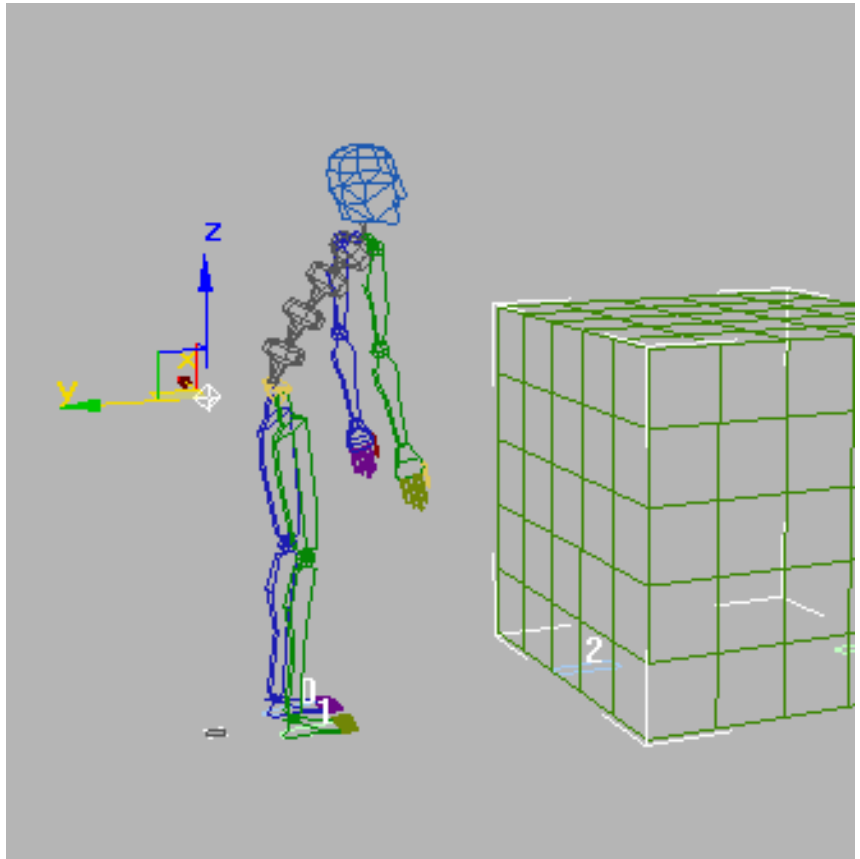
The biped moves so his hands are no longer touching the box. Notice that, for this figure, the spine objects are rotated so the biped has a rounded back.



- 3  In Track Selection rollout, click Body Horizontal.
- 4  Expand the expansion bar in the Biped Rollout. In the Modes group, turn on Rubber Band Mode. Then move the biped's center of mass so it's back inside the body.
- 5 Turn off Figure mode and play the animation.

The upper torso moves back over the feet. The illusion of weight is diminished.

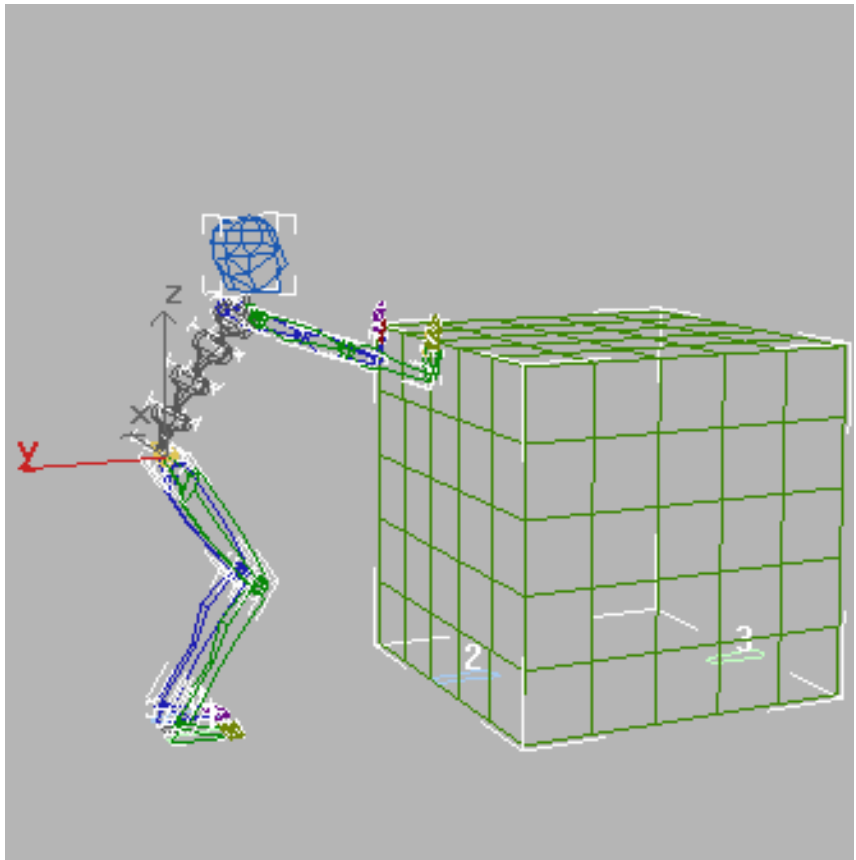

- 6 Turn on Figure mode. Move the center of mass far behind the body, and then turn off Figure mode.

The biped leans into the box, as though the box were heavy.

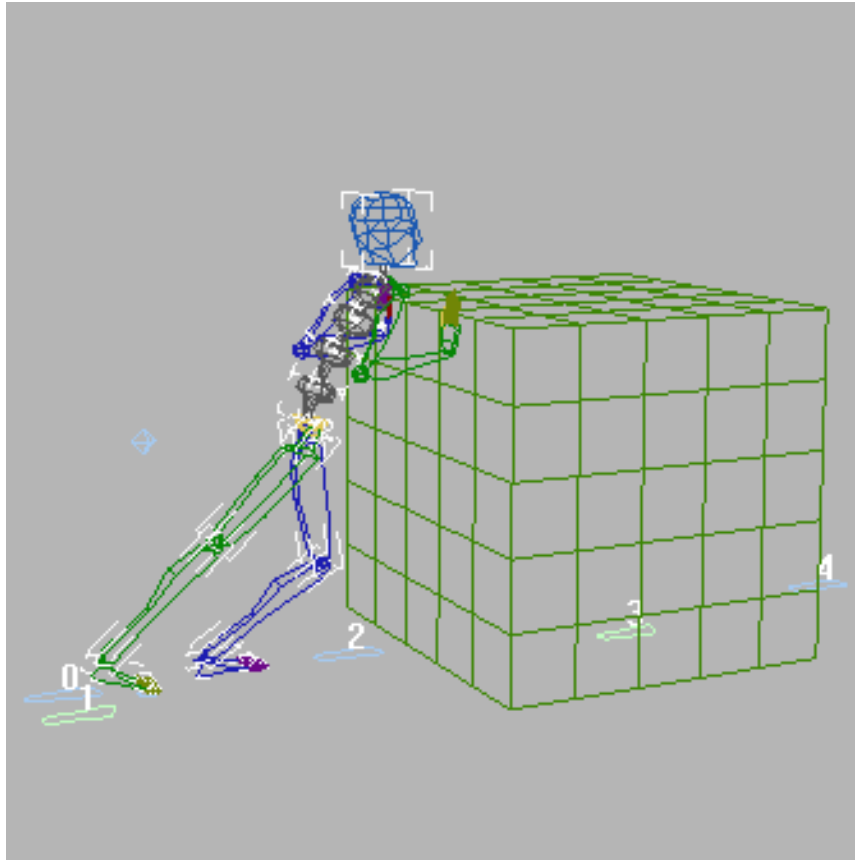

7 Play the animation.

Using Props

Props are objects that a biped might be carrying or swinging, such as a sword, spear, or “lightsaber”. They are parametric objects that are included as part of the biped skeleton, so that if you have motion capture data with prop information, there is a place for that information to reside. You can have up to three props saved with the biped.

Props have two parameters for Position Space and Rotation Space that can be keyframed. This makes it easy to have the prop follow the biped's hand, or to switch the prop from one hand to another.

Add a prop to an animated biped:

This procedure starts with a biped sawing a board. You'll create a prop to take the place of the saw.

- 1 Open *saw_wood_start.max*.

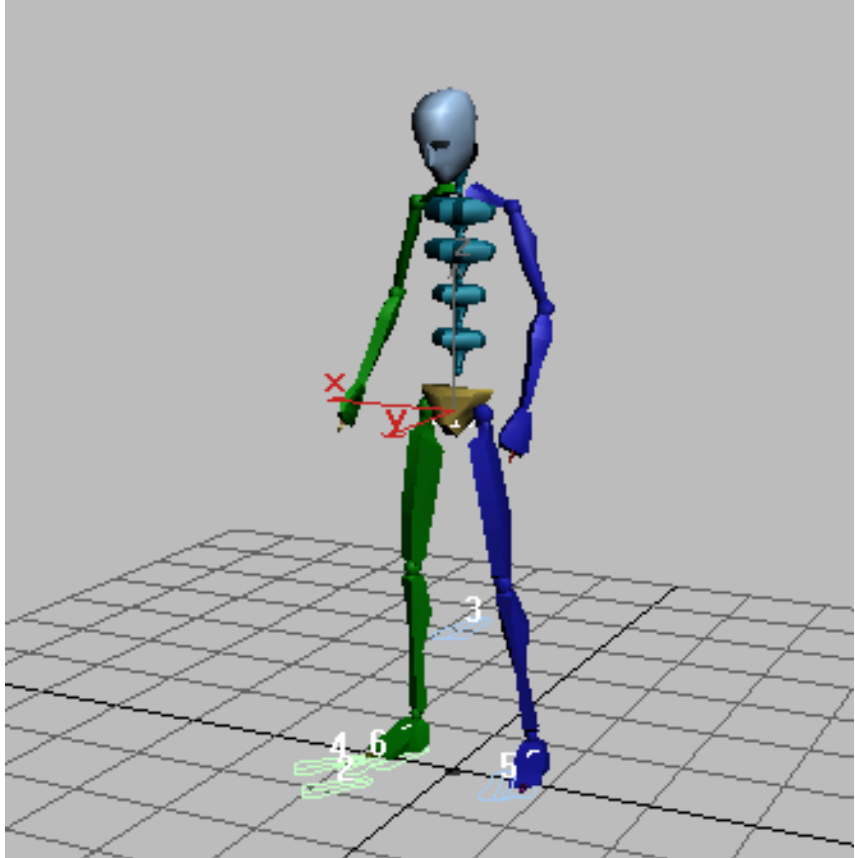

- 2 Play the animation. The biped rests one knee on the invisible board, and saws it with an invisible saw.

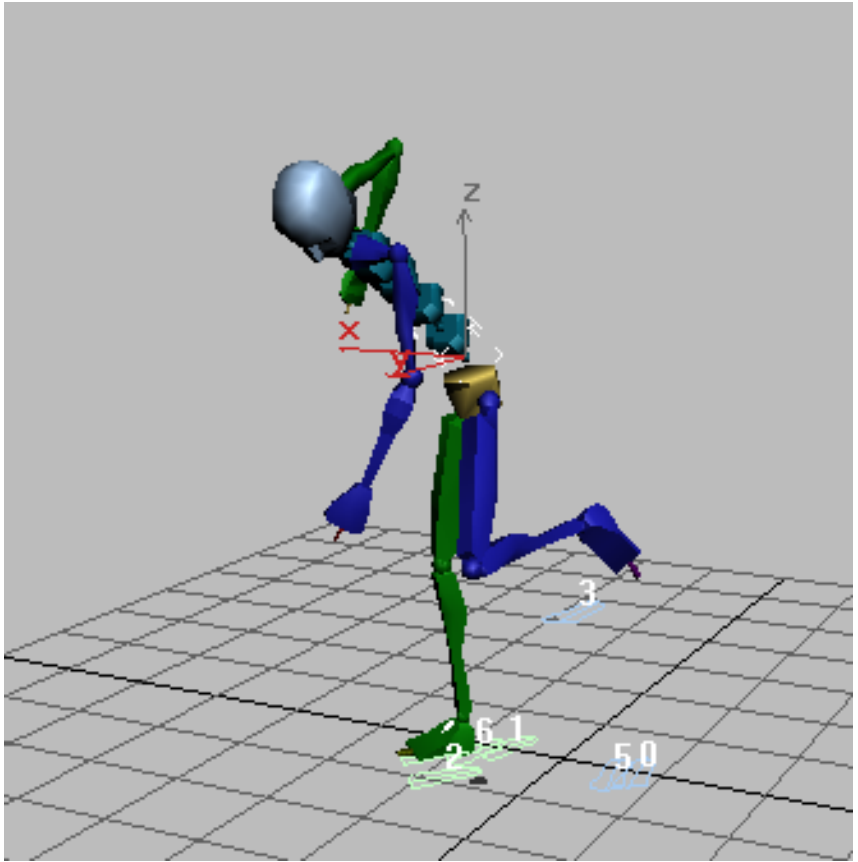

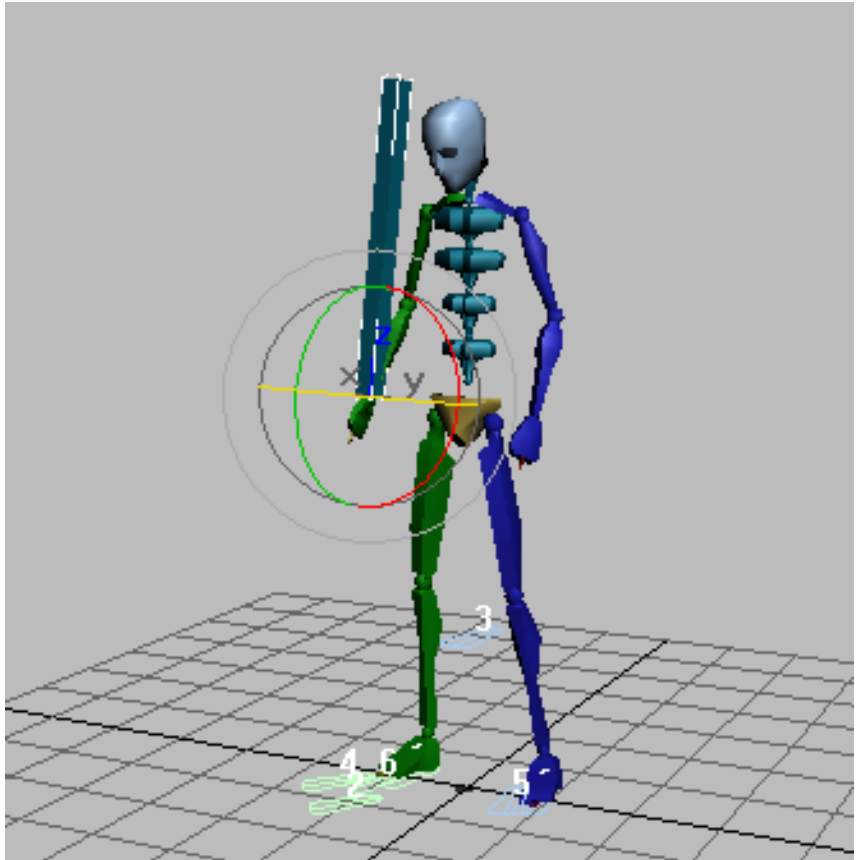

- 3 Select any part of the biped and open the Motion panel.
- 4  On the Biped rollout, click Figure Mode.
In the Perspective viewport, the biped shifts to a different position.
- 5 To create a prop, open the Structure Rollout and turn on Props 1.
The prop appears at the biped's right hand.

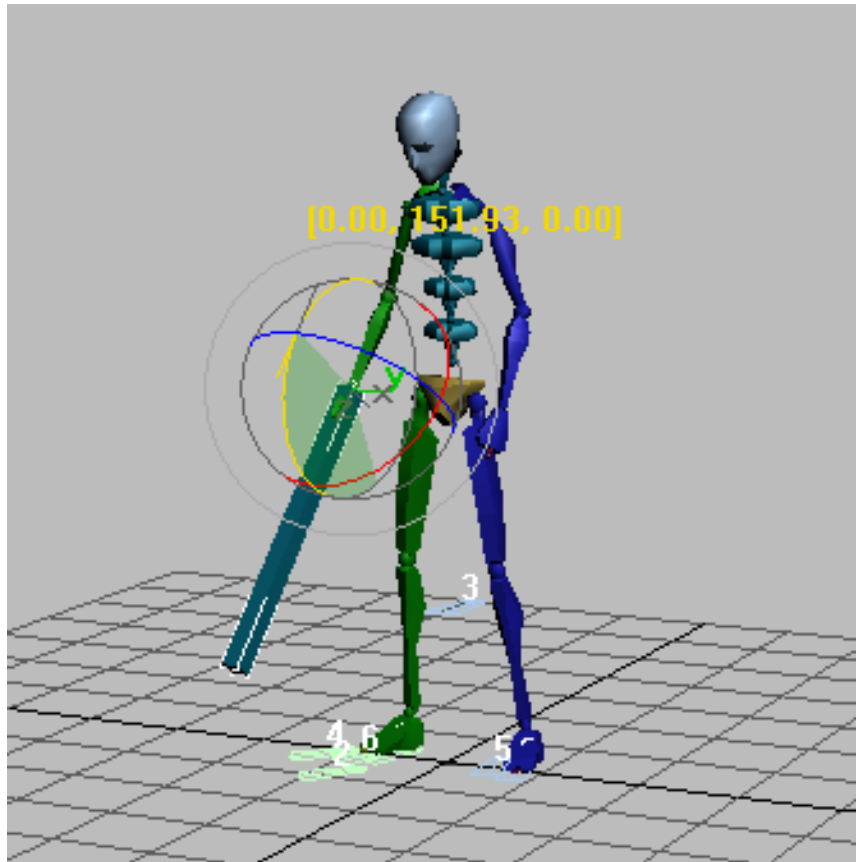

To align and position the prop to the hand, you'll leave Figure mode and set a key for the prop.

- 6 Turn off Figure Mode, and then select the prop in the viewport.
- 7 Move the time slider to frame 0.
- 8 In the Perspective viewport, rotate the prop approximately **152** degrees around the Y-axis.
The rotation is displayed in yellow in the viewport, and in the Coordinate Display below the viewport.



- 9  On the Key Info rollout, click Set Key.
- 10 Expand the Prop divider bar. In the Rotation Space drop-down list, choose Right Hand.
This puts the prop in right-hand rotation space. As the right hand rotates, the prop will follow. Notice that you can't make changes here unless you have set a key.
- 11 On the main toolbar, click Select And Move, and then change the Reference Coordinate system to Local.
- 12 In the Perspective viewport, move the prop along the Z-axis so it is slightly in front of the hand, then click Set Key again to keyframe the position of the prop.

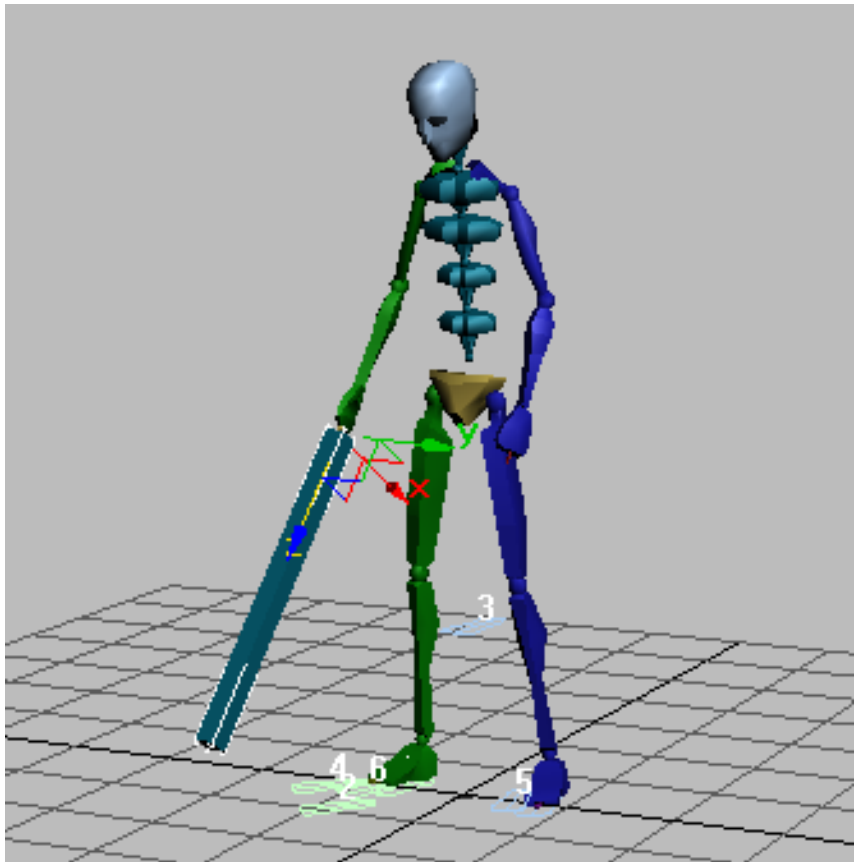

- 13 Play the animation. The prop follows the movement of the hand nicely.
- 14 To make the prop more closely resemble a saw, turn on Figure mode and scale the prop so its proportions match those of a hand saw. Then turn off Figure mode and play the animation.

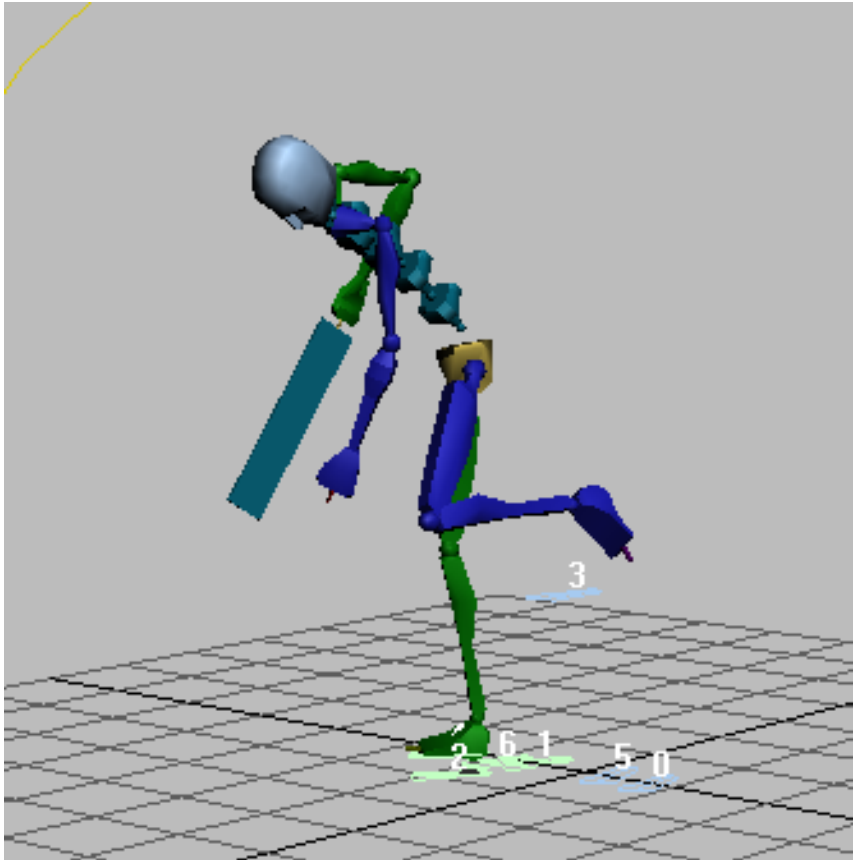

If you like it, save your work to **mysawingwood.max**.

Animate props switching hands:

This procedure starts with a file of an animated biped. You'll add a prop, and then keyframe it to switch hands to follow the motion.

- 1 Open *samurai_start.max*.
- 2 Play the animation.
The biped first holds his weapon in one hand and then swings it with the other.
To create a prop you will go into Figure mode.
- 3 In the viewport, select any part of the biped.

- 4  Open the Motion panel, and on the Biped rollout, turn on Figure Mode.
- 5 Open the Structure rollout and turn on Props 1.
The prop appears in the viewport beside the biped's right hand.
- 6 Turn off Figure mode and play the animation.
The prop follows the movement of the pivot point of the right-hand wrist. To adjust the size of the prop, you can use the Scale transform.
- 7 Turn on Figure mode and select the prop.
- 8 On the main toolbar, choose either Scale or Non-Uniform scale to change the size and proportions of the prop. Turn off Figure mode when you are through.
- 9 Turn on Auto Key mode. Rotate the prop so it's perpendicular to the hand.

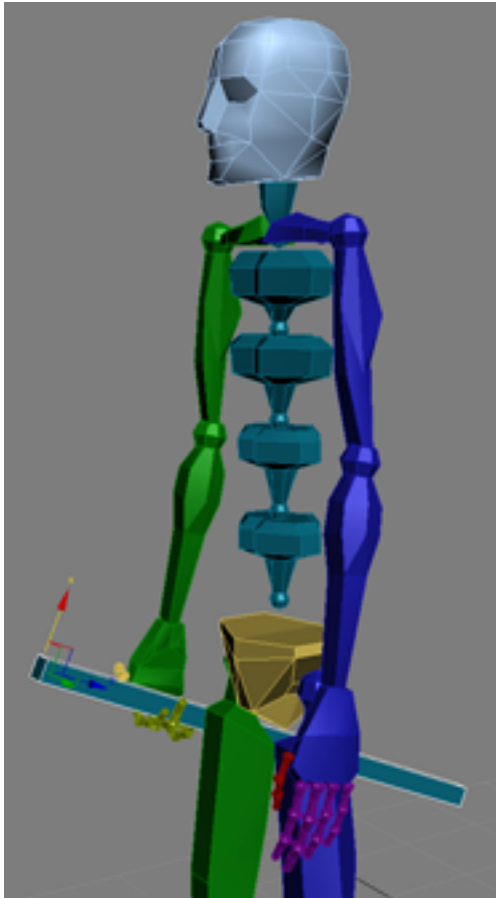

Rotate and move the prop near the palm of the hand.

- 10** On the main toolbar, click Select And Move. Then in the Reference Coordinate drop-down list, choose Local. Move the prop on its local X and Y-axes so the prop is in contact with the palm of the hand. Make sure to leave enough room between the prop and the right thumb so the left hand can grab it as well.
- 11** Make sure that the prop is still selected, and then open the Key Info rollout.
- 12** Expand the Props bar, and click Set Key so the Position Space and Rotation Space fields are accessible in the Props group.

- 13 Using the drop-down list, change both Position Space and Rotation Space to Right Hand.
- 14 Play the animation.
The prop follows the movement of the right hand throughout the whole animation.

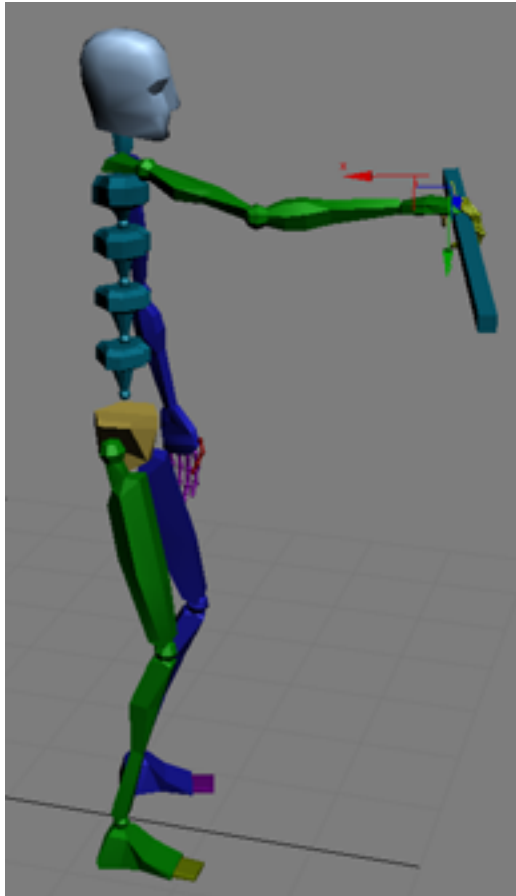

Prop follows the right hand.

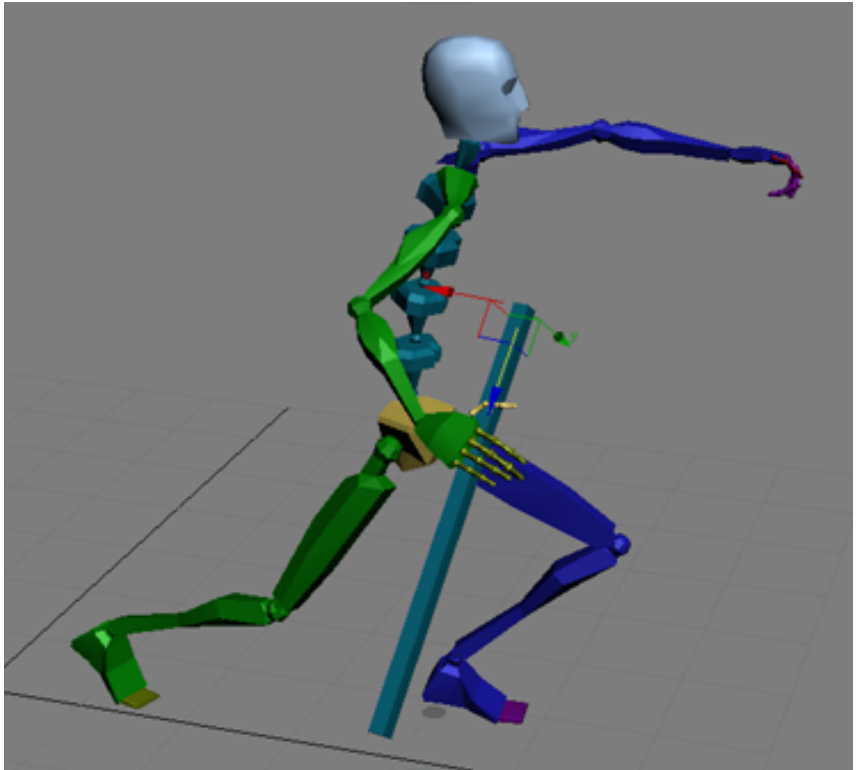

Prop follows right hand for the entire animation.

To make the biped switch hands, you can keyframe the Position and Rotation Space.

- 15** Move to frame 74. The prop should still be selected. In the Key Info rollout, click Set Key.
This sets a key
- 16** Move to frame 75, and click Set Key.
This activates the Position and Rotation Space fields.
- 17** Change Position Space and Rotation Space to Left Hand. Now play the animation.
The prop follows the movement of the right hand until frame 75. It follows the movement of the left hand from 75 to the end of the animation.

18 Play the animation.

The prop follows the movement of the hands correctly. The prop follows the right hand until frame 75, then switches and follows the left hand until the end of the animation.

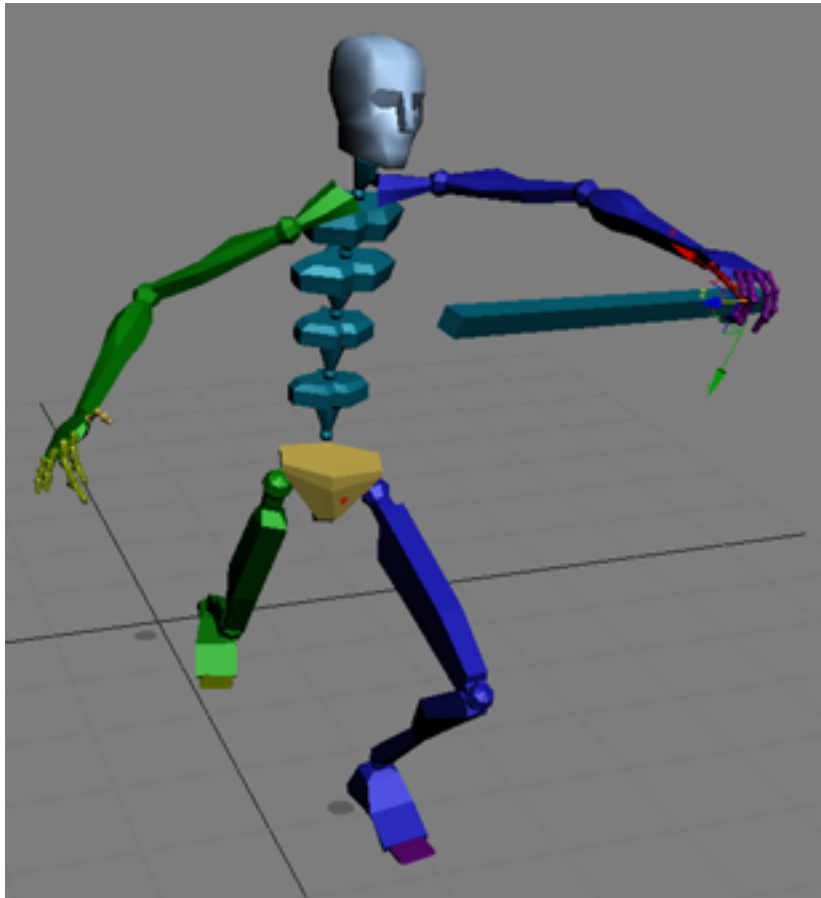

Prop follows the other hand.

19 Depending on the length of the prop, you may find that it passes through the head or other body part. If this happens, you can keyframe the rotation of the hand so the prop avoids this intersection. You can also keyframe the prop independently of the hand, if needed.

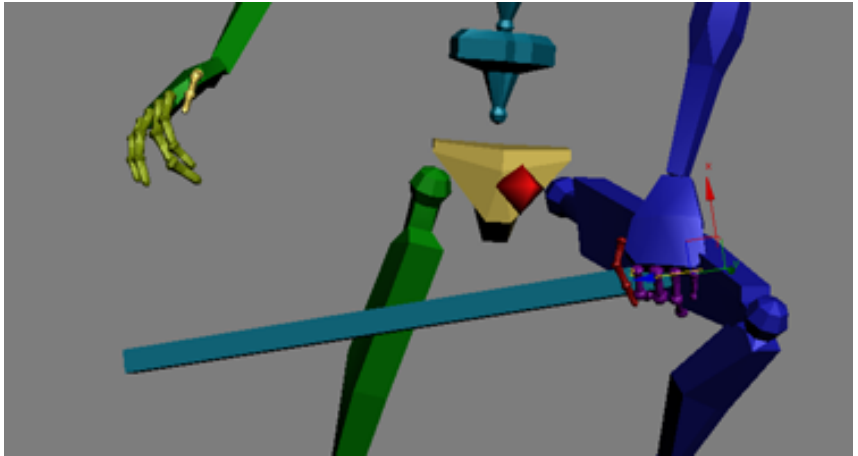

The prop may intersect the leg.

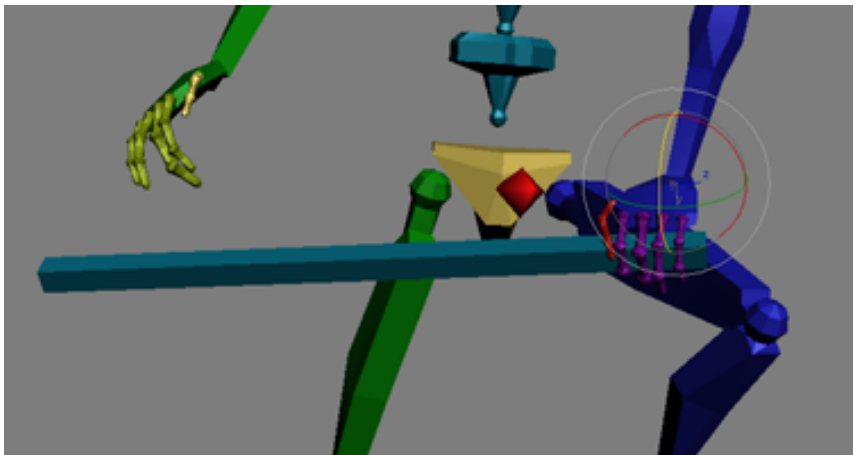

Rotate the hand or the prop to correct.

20 Save your work as **mysamurai.max**.

Making the Biped Look at Objects

You can easily have a biped's head look at another object in the scene. In this lesson, you'll animate a biped watching a table tennis match.

Set up this lesson:

- 1 Open *lookat_tabletennis_start.max*.
- 2 Play the animation in the Perspective viewport.
The ball bounces back and forth over the net four times, then the ball bounces up and done in place four times.

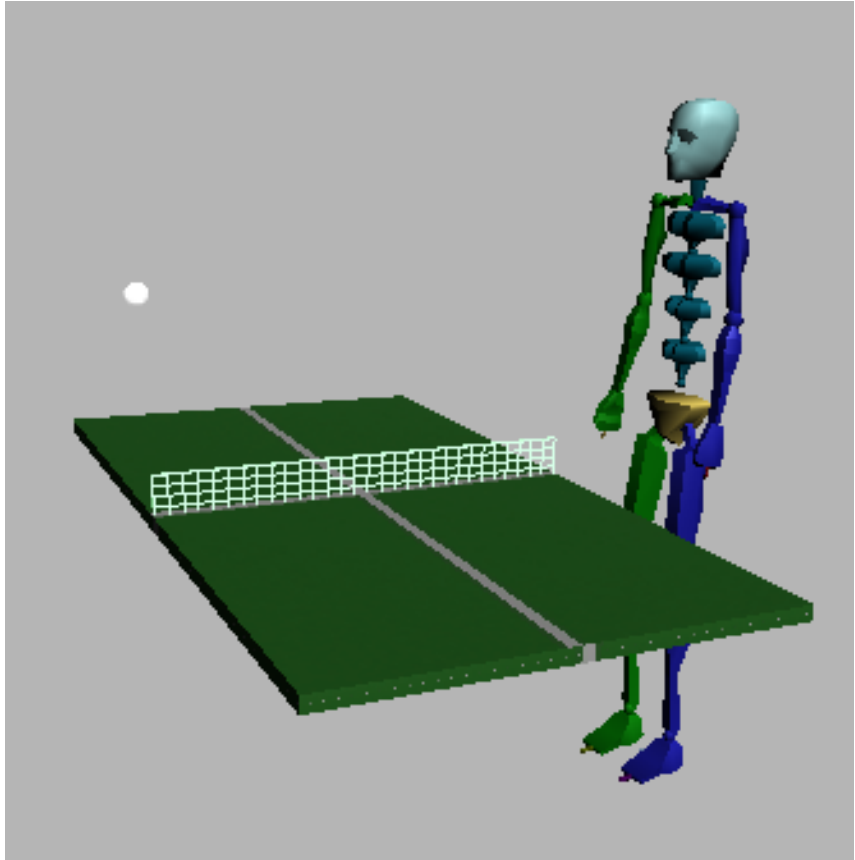

Ball bounces, but biped isn't watching.

Make the biped look at a target:

Suppose you want to animate the biped watching the ball going over the net, but not follow the bounce in place. By animating Target Blend, you can create this effect.

- 1** In the Perspective viewport, select the head of the biped. Open the Motion panel.
- 2** Open the Key Info rollout and expand the Head bar. On the Key Info rollout, click Set Key.
The Target Blend field becomes available.
- 3** Click the Select Look At Target arrow, below the Target Blend spinner, then click the table tennis ball in the viewport.
The name *pingpongball* appears in the field.
- 4** Change Target Blend to **1**.
The biped is now looking at the ball.

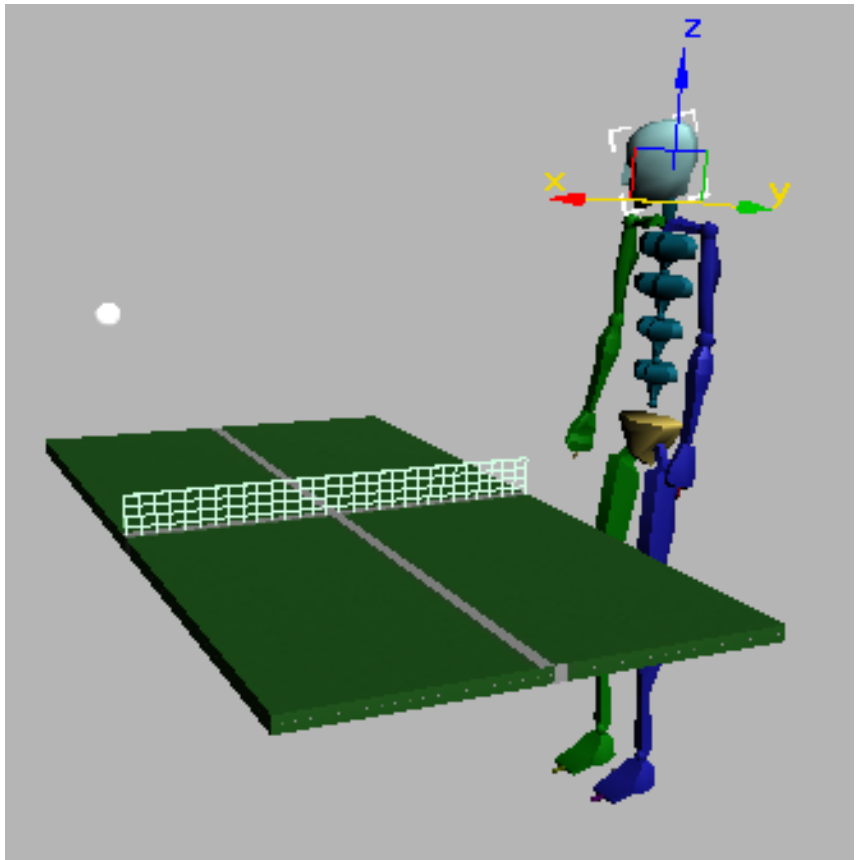

The biped looks at the ball automatically.

- 5 Play the animation.
The biped watches the bouncing ball intently.

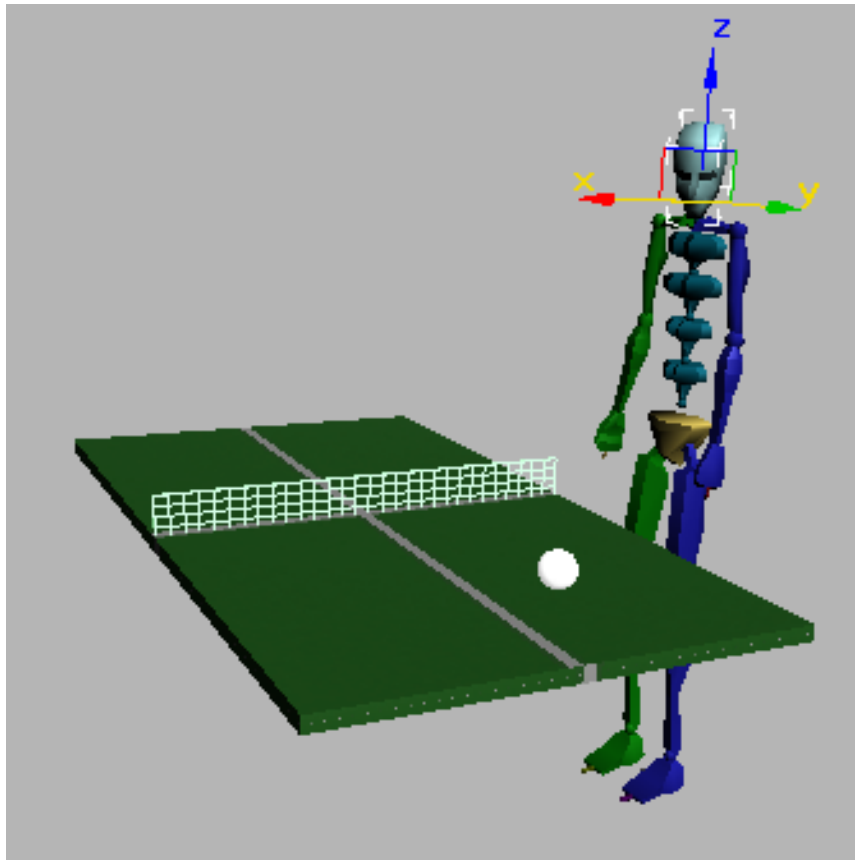

The biped's head follows the movement of the ball.

Make the biped look around:

In this procedure, you make the biped look around as the ball bounces in place.

- 1 Move the time slider to frame 200.
At frame 200, the period begins where the ball bounces in place.
- 2 On the Key Info rollout, click Set Key and set the Target Blend to **0**.
- 3 Move to frame 199. On the Key Info rollout, click Set Key and set the Target Blend to **1**.

Between frames 0 and 199, the Target Blend parameter is set to 1; at frame 200, it changes to 0. Setting these keys this way is a way to control interpolation. You could also change the interpolation for the key at frame 200 to a step value coming in, and then not bother setting the other key.

- 4 Move the time slider to frame 210. Rotate the head so it's looking away from the bouncing ball.
- 5 Add more rotation keys to the biped's head until frame 300.

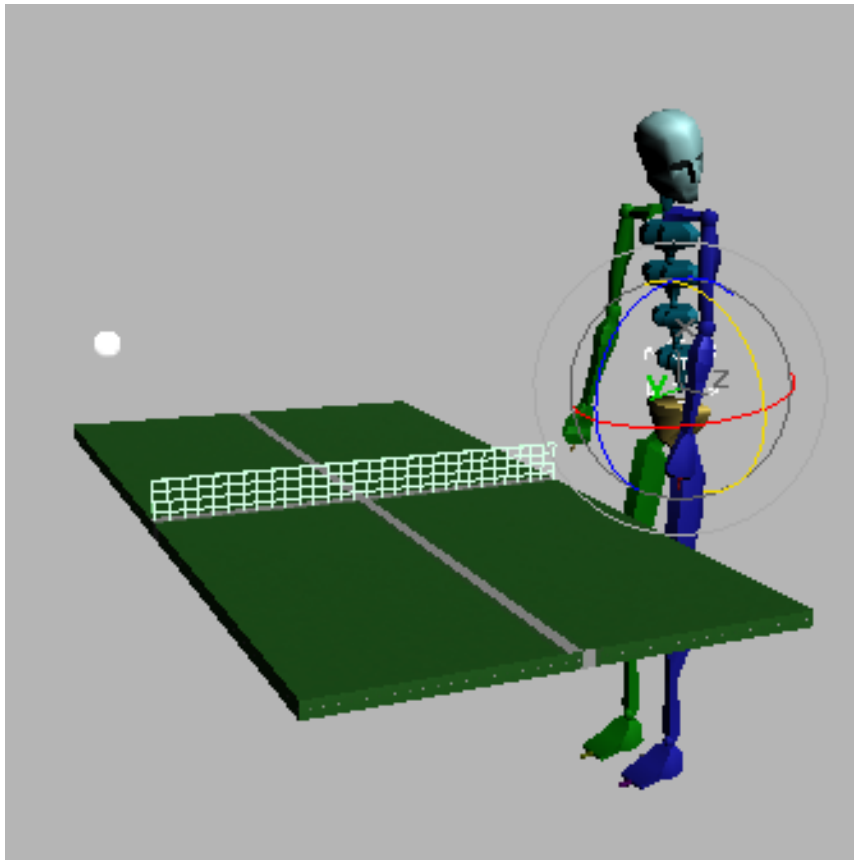

Rotate the biped head freely when Target Blend is zero.

- 6 Play the animation.

The biped looks at the ball bouncing over the net, but then switches focus to something else.

NOTE You can't select multiple objects within a single animation. If you need to do that, try using a List Controller with several LookAt constraints, then animate the weights of the list items.

- 7 Save your work as **mylookat_tabletennis.max**, or open *lookat_tabletennis_final.max* for comparison.

Using In Place Mode

When you're animating a character that's moving through space, it's hard to evaluate the motion when the character moves out of your view. You can use In Place mode to keep the viewport centered on the moving character.

Use In Place mode:

- 1 Open *Inplace_start.max*.
- 2 Play the animation.

This is an animation of a biped running. You can see the entire animation, but you're too far away to see what's really going on.



3 At frame 0, select the entire biped with a selection rectangle.

4  Choose Zoom Extents Selected from the flyout.

The viewport zooms to frame the biped, and you can see the pose clearly.

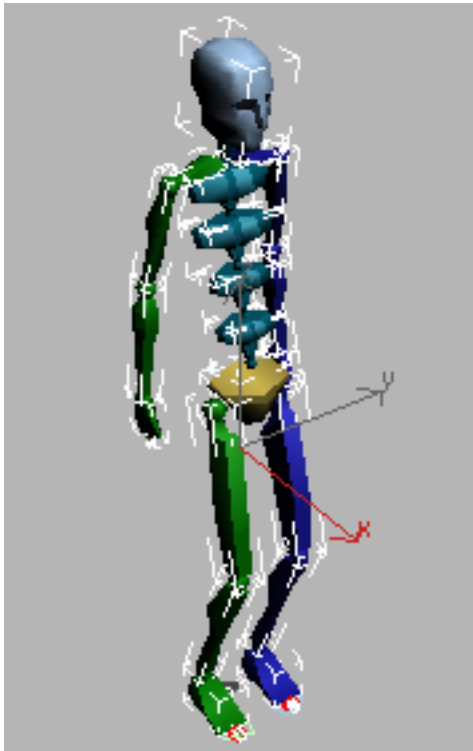

5 Open the Motion panel.



6 On the Biped rollout, click the plus to expand the expansion bar. In the Modes group, turn on In Place mode.

7 Play the animation in the Perspective viewport.

8 While the animation is playing, click Orbit in the viewport navigation controls.

Orbit lets you rotate the viewport while the animation plays.

9 Rotate the viewport around while the biped is running, so you can see the animation from all sides.

Since you are using In Place mode, the biped remains in view and never leaves the frame.

TIP If you click In Place mode and the biped disappears, navigate the viewport to the center of the home grid. In Place mode plays the biped animation at this location.



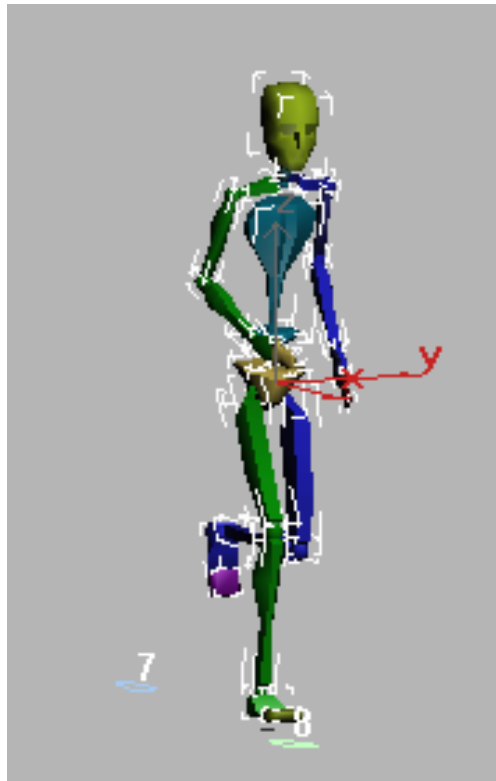



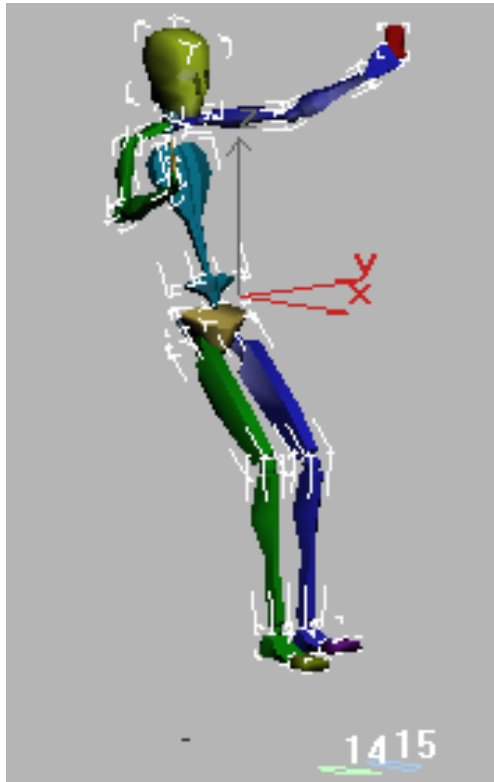

You can use In Place mode when you need to view and adjust the animation of a biped that moves beyond the confines of the viewport. In Place mode is just a viewing mechanism: it doesn't actually create an in-place animation. To change the animation so the biped stays in the same space, create a dummy object and link the COM to the dummy. Then keyframe the dummy so that the biped stays in the same place as the animation progresses.

Summary

This tutorial showed you a biped can interact with objects in its environment, including linking hands so they hold objects, or feet so they stand on other objects. It also showed how to create the illusion of weight by adjusting the biped's Center Of Mass. It showed using a Look At target so the biped appears to watch a moving object. Finally, it showed how In Place mode to preview the motion of a biped that moves out of a viewport's field of view.

Animating Multi-legged Characters

This tutorial has two parts. In the first, you'll use a biped to animate a quadruped (four-legged creature). In the second, you add extra bones to animate a pair of wings on an imaginary four-legged creature.

In this tutorial, you will learn how to:

- Animate a walk cycle for a typical quadruped such as a dog.
- Use the ForeFeet toggle for a biped.
- Use Bones to create extra limbs.

Skill level: Intermediate to Advanced

Time to complete: 2.5 to 3 hours



Animating a Quadruped Walk

In these lessons, you'll animate a four-legged character, a dog, to walk in a continuous way. You'll use the ForeFeet option to make the fingers of the biped hands behave like toes on forefeet.

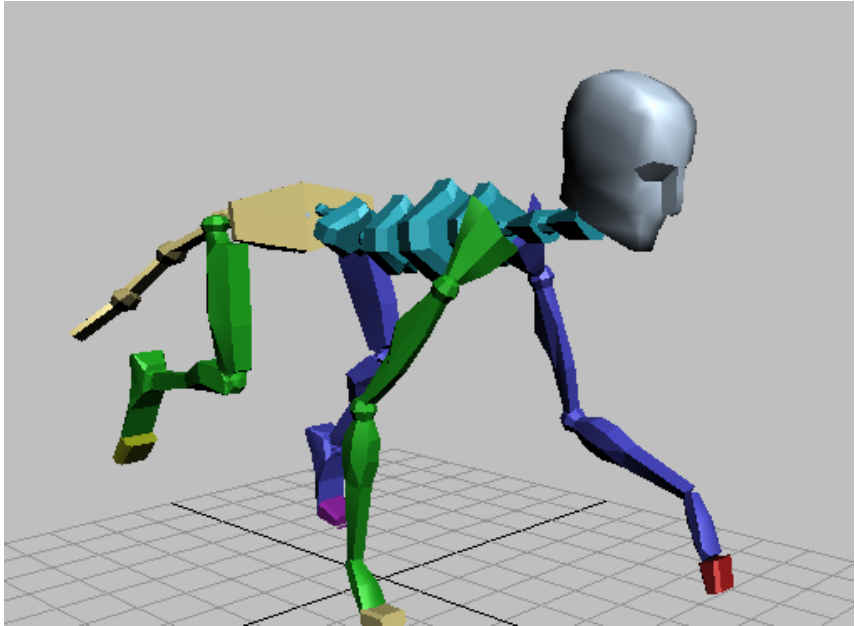

A Quick Review of a Biped Walk

If you don't use Biped to create a walk for you, it helps to know that a human walk cycle is defined by two steps: left foot to right foot, followed by right foot to left foot (or vice versa). The two steps break down into four states:

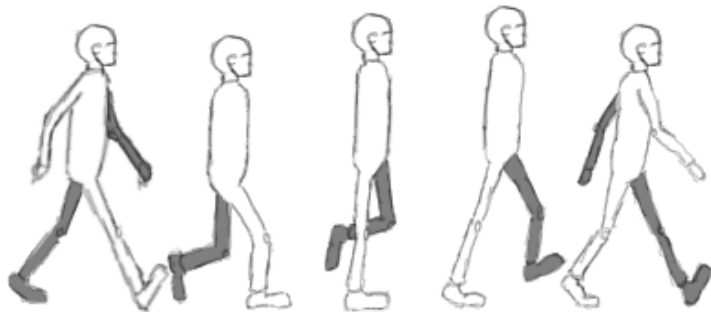

Left to right:
1. Contact

2. Down
3. Passing
4. Up
5. Contact again (same as 1, but with legs reversed)

- 1 **Contact:** Both feet are on the ground. At this point, the stride is at its longest: this is known as an *extreme pose*.
- 2 **Down or “Recoil”:** After contact, the weight goes down on the front leg. The body lowers, and both legs bend.
- 3 **Passing or “Breakdown”:** The front leg straightens and the back leg passes it. The body raises to a point that is higher than in the contact position.
- 4 **Up or “High Point”:** The back foot is now the front one, and is about to make contact. The other foot pushes up and forward, raising the body to its highest position.
- 5 **Contact:** The same as pose 1, but with the opposite leg forward.

You can start animating the cycle at any of these poses. Animators often prefer to begin with the contact pose, as that pose (in general, any extreme pose) is a good reference to build from.

You have to decide how many frames the walk cycle will use. 12 frames yields two steps per second: this is a natural pace, which we will use in this tutorial. Cartoonists sometimes use an 8-frame cycle to create a fast, humorous walk. A 24-frame cycle would give (for film) one step per second, suitable for a slow-moving character.

The Walk Cycle for Quadrupeds

A quadruped walk is essentially two biped walks linked together, but out of phase with each other. When a biped walks, the shifting weight on the pelvis causes the up-down motion just described. For a quadruped, the same weight shifts occur for the pelvis *and* the shoulders.

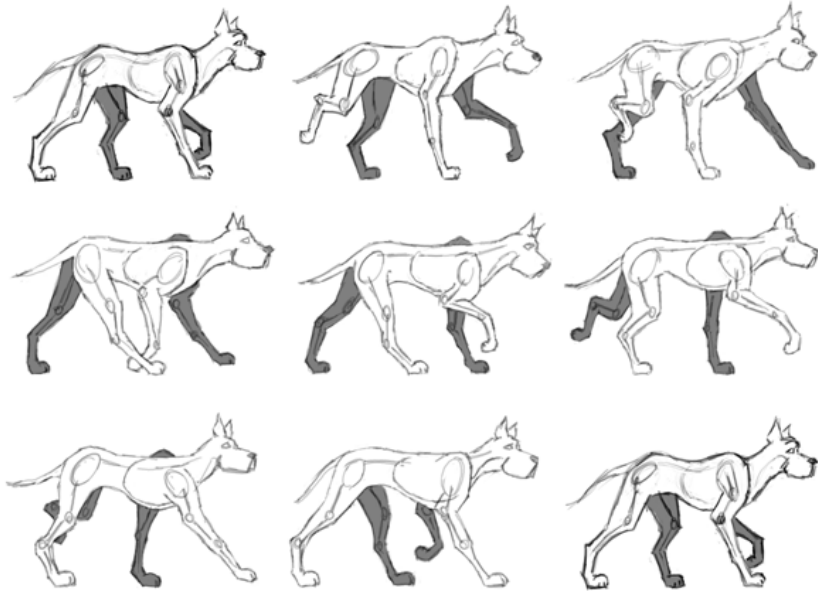

Quadrupeds have different proportions than human bipeds. In particular:

- The rib cage is elongated downwards, unlike the flatter human rib cage.
- The shoulder blades lie along the side of the rib cage, not on the back.
- There are no collarbones.

The lack of collarbones gives the shoulder blades more freedom. This affects weight distribution on the front legs.

When you use Biped to animate a quadruped, its “clavicle” parts behave more like shoulder blades.

In spite of these differences, and some others we will mention later, a 3ds Max Biped can model a quadruped quite well.

Set Up the Scene

The first steps are to configure animation for the walk cycle, and then to adjust the biped

Set up the lesson:

-  On the Quick Access toolbar, click the Open File button, navigate to the `\animation\character_animation\quadruped` folder, and open `quadruped_walk_1.max`.
If a dialog asks whether you want to use the scene's Gamma And LUT settings, accept the scene Gamma settings, and click OK.
This file contains the biped used for the dog. It is posed on all fours, and has a tail.

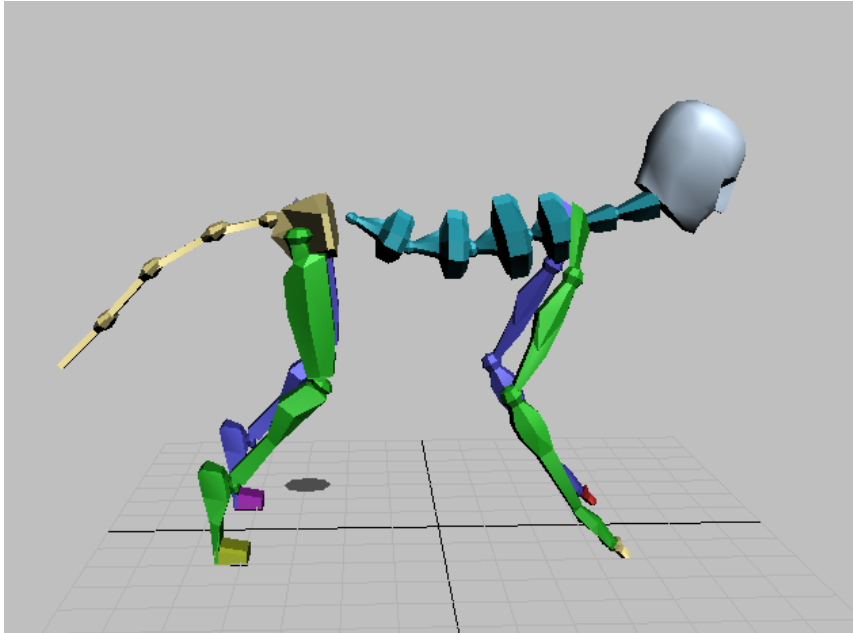

If you prefer to start from scratch, you can duplicate this pose by rotating and moving the biped's pelvis, arms, and head.

Configure time and Auto Key behavior:

- 1  Click the Time Configuration button to open the Time Configuration dialog.
This button is located among the animation playback controls.



- 2 In the Frame Rate group, choose Film. This sets the frame rate to 24 frames per second.

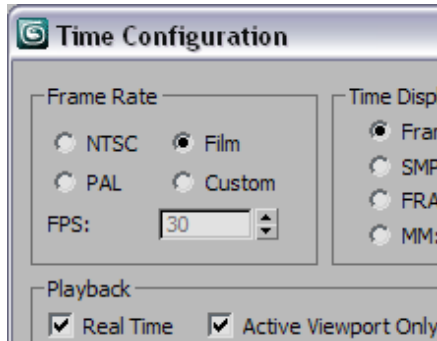

The rate of 24 fps is easier to work with, given our choice of a 12-frame cycle for each pair of limbs. If later you want to output to NTSC video, which has a frame rate of 30 fps, you can change the rate before you render.

- 3 In the Animation group, change Start Time to **1** and End Time to **25**.

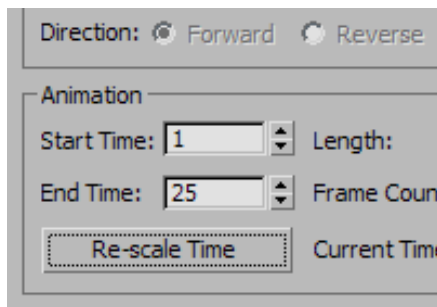

This gives a 24-frame animation, with an extra frame at the end so the walk cycle loops smoothly when you play it as feedback in 3ds Max viewports. When you're done, frame 1 and frame 25 will have the same pose. If you were using the walk cycle in another context (for example, moving the walking dog along a path), you would trim off frame 25 and use the cycle of frames 1 through 24 in the larger animation.

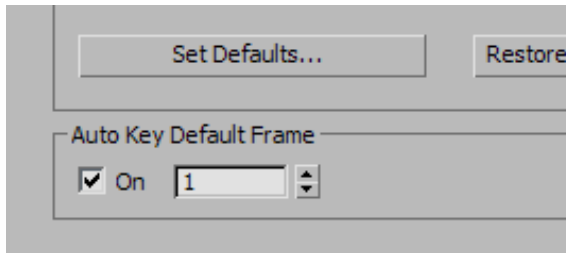

- 4 Click OK to close the Time Configuration dialog.

- 5 Choose Customize > Preferences, and go to the Animation tab. In the Auto Key Default Frame group, make sure On is turned on, and change the frame value to 1.





This sets Auto Key to set an original-value key at frame 1, the first of this animation, when you create a key at a different frame.



Set the biped to use ForeFeet.

- 1  Click any part of the biped to select it, then go to the Motion panel.
- 2  On the Biped rollout, click Figure Mode to turn it on.
- 3 Open the Structure rollout, and then click ForeFeet to turn it on.
ForeFeet causes the biped fingers to behave like toes. You can think of this option as “Four Feet.”

NOTE This biped has just one toe for each foot and one finger for each hand. For most quadrupeds, the toes move as a group when walking, so the simplest model works well.

- 4  Click Figure Mode again to turn it off.
- 5  Change the viewport to a Left view, then click Zoom Extents.

- 6  Select the biped's right finger, and rotate it so it is parallel with the ground plane: about -30 degrees in the local Z axis.

- 7   Use Select By Name to select the biped's left finger (*Bip01 L Finger0*), and rotate it as you did the right finger.

TIP Another difference between the anatomy of humans and most quadrupeds (elephants are a notable exception), is that the hind legs appear to have an extra joint. Actually, this is because the foot is extended, and the weight rests on the ball of the foot. In Biped, you can add an extra joint or “link” to the leg, but increasing Leg Links to 4 causes Biped to generate additional animation keys that you might not want. It seems easier to leave Leg Links at its default of 3, and increase the length of the foot link, as has been done in this model.



Elongated hind foot in a familiar quadruped

Save your work:

- Save the file as **my_quadruped_adjusted.max**.

Next

[Block the Steps for the Forelegs](#) on page 1001

Block the Steps for the Forelegs

Now that you've adjusted time settings and the biped itself, you're ready to block the basic walk cycle, working from pose to pose. This involves positioning

the legs in space and time, giving the walk its overall tempo. You will begin with the quadruped's forelegs.

Set up the scene:

-  On the Quick Access toolbar, click the Open File button, navigate to the `\animation\character_animation\quadruped` folder, and open `quadruped_walk_2.max`.

If a dialog asks whether you want to use the scene's Gamma And LUT settings, accept the scene Gamma settings, and click OK.

This scene is the same as the one you just saved, but a set of reference poses has been set up on planes in the background.

Configure character studio:

- 1  Use Orbit to change the viewport so you can see all four of the quadruped's feet.

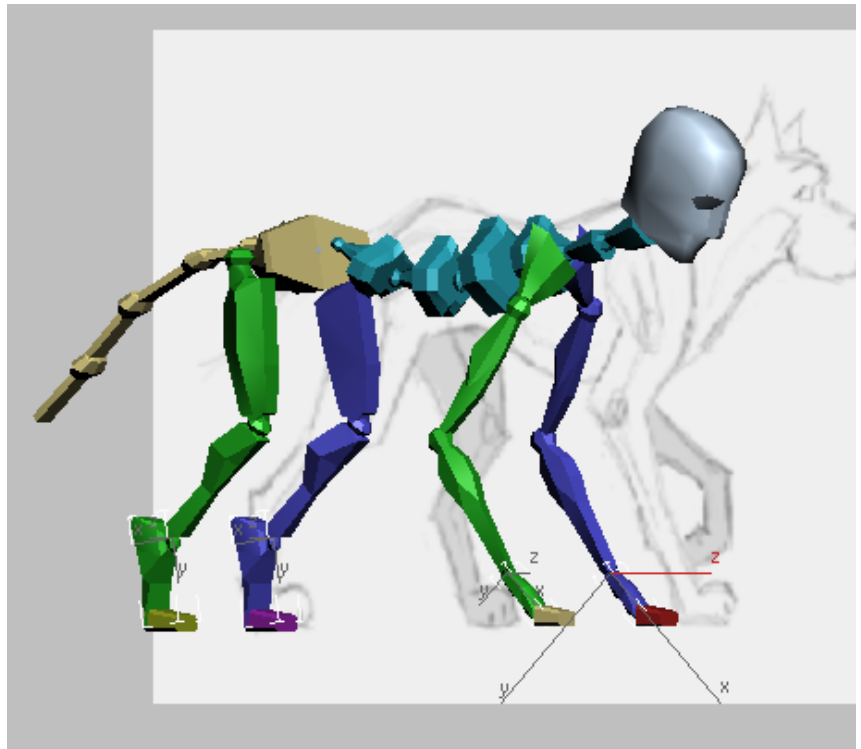

2 Use Ctrl+click to select both hind feet and both hands (forefeet).



3 On the Motion panel > Quaternion/Euler rollout, choose Euler. Euler keys have tangent controls, which can be useful for this walk cycle exercise.



4 On the 3ds Max status bar, to the right of the Set Key button, choose Linear as the Default In/Out Tangent type. Sometimes blocking the animation is easier without extra interpolation (which you can add later).



- 5 Also on the Motion panel, open the Key Info rollout and expand its IK group (click the plus-sign icon to the left of the IK label).



- 6 Finally, open the Copy/Paste rollout as well.

TIP To see both the expanded Key Info rollout and the Copy/Paste rollout, it might help to make the Command panel two columns wide: drag the left border of the Command panel to the left to make the Command panel wider.

- 7 Press Shift+Z to undo the viewport change and return to the Left view. (Depending on how you adjusted the viewport, you might have to click Shift+Z more than once to return to the Left view.)

Begin posing the front legs:



- 1 Make sure you are at frame 1, then turn on Auto Key.



- 2 Use both Move and Rotate to position the arms (forelegs) and hands (forefeet) to match the reference sketch. This is the Passing pose. (The quadruped's hind legs are in the Down pose.)



TIP While a single biped (quadruped) part is selected, the PageUp and PageDown buttons move up and down the hierarchy.

You don't have to match the sketch accurately: a general idea of the pose is the goal.

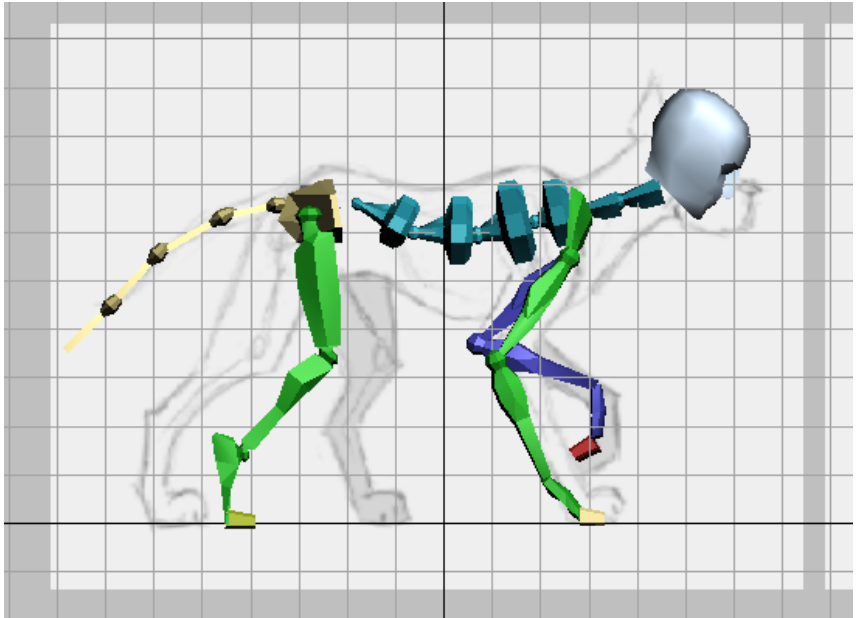

TIP If you find it difficult to select a part of the arms by clicking, use Select By Name.



- 3   Select the right hand (forefoot), then on the Key Info rollout click Set Sliding Key. Do the same for the left hand (forefoot).

NOTE Both Set Planted Key and Set Sliding Key set IK Blend equal to 1, but only Set Planted Key turns on Join To Prev IK Key. Join To Prev IK Key causes the limb to snap to the pivot set in the previous IK key. Set Sliding Key doesn't cause the pivot snap; this contributes to a more natural motion for the forelegs.

One advantage of the ForeFeet toggle is that it lets you set keys such as this for “hands” on the ground plane, as you do for feet.

NOTE The track bar shows sliding keys in yellow, planted keys in orange, and free keys in gray.

- 4  Double-click the right clavicle to select the entire arm (foreleg), then on the Copy/Paste rollout, click Copy Posture.

- 5 In the Copy/Paste rollout > Paste Options group, under Auto-Key TCB / IK Values, choose Copied.

When Copied is chosen, IK info is pasted along with the new key. When Default is chosen, IK info is not pasted and the new key is a free key, FK rather than IK, which is not what you want for this animation.

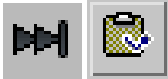

- 6 Go to the last frame (frame 25), and then click Paste Posture.



- 7 Go to frame 13, and then click Paste Posture Opposite.

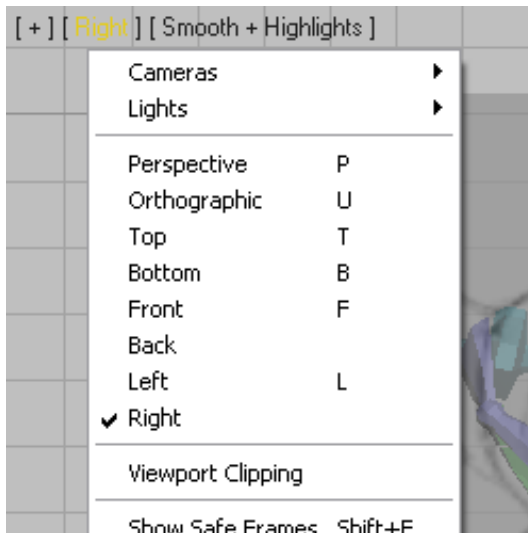

Frame 13 is the midpoint of the walk cycle animation: frames 13 through 24 are essentially the same poses as frames 1 through 12, but with the legs in opposite positions. (Frame 25 is the same as frame 1, so that the animation will play as a seamless loop when you preview it in viewports.)

- 8 Click the Point Of View (POV) viewport label, and choose Right to change the viewport to a Right viewport.



- 9 Go to frame 1, double-click the left clavicle to select all the left arm (foreleg).

- 10  Click Copy Posture.

- 11   Go to frame 25, then click Paste Posture.

- 12  Go to frame 13, then click Paste Posture Opposite.



Now the forearms/legs have the same posture in the extreme poses: the first and last frames of the cycle, and the mid frame.

TIP When you use Paste Posture Opposite, don't be alarmed that a key doesn't appear on the Track Bar: the original limb is still selected, so you won't see keys for the opposite limb.

- 13 Press Shift+Z to undo the viewport change and return to the Left view.

Add the other three poses:

- 1  Make sure that Auto Key is still on.

- 2   As in the previous procedure, use Move and Rotate to set up the transitional poses, as follows:

- **Frame 4, Up**

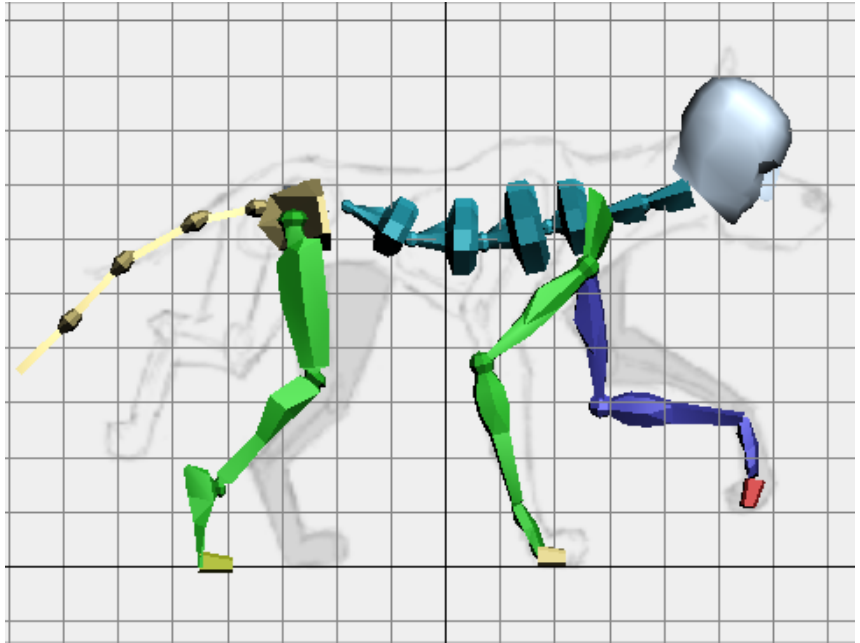

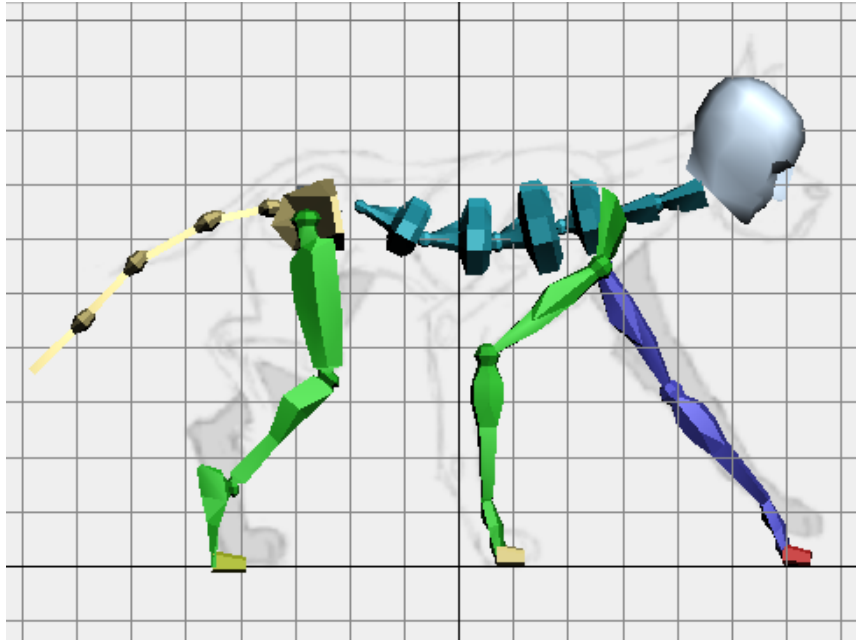

■ Frame 7, Contact

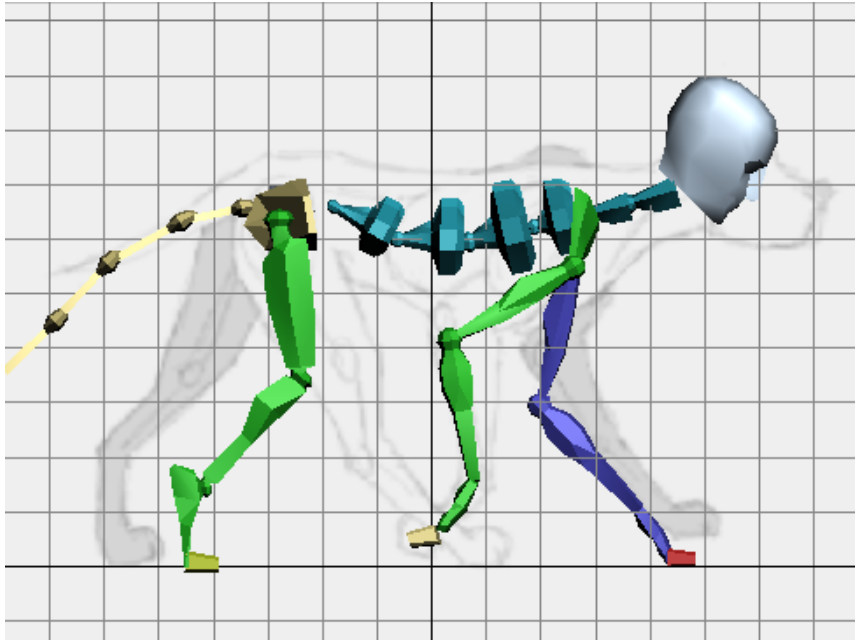

NOTE The sketches have a bit of perspective, so the left feet appear a bit raised from the ground plane, but as you're working in 3D, at contact both feet can rest on the ground.

■ **Frame 10, Down**



-   Also as earlier, after you create each pose, select the right forefoot and click Set Sliding Key, then do the same for the left forefoot.



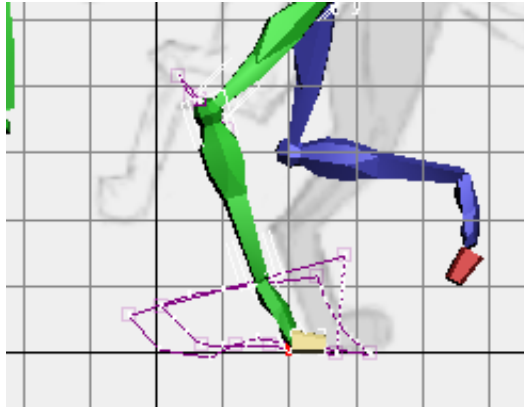

Check your work by looking at trajectories:

- 1 Double-click the right clavicle to select all of the right foreleg.
-  2 On the Key Info rollout, click Trajectories to turn it on.
- 3 Scrub the time slider.
The elbow trajectory describes an arc, and the foot trajectory describes a rough trapezoid.



- 4 Double-click the left clavicle to see the trajectories for that limb, as well.

Copy poses to the second half of the cycle:

- 1  Go to frame 4. Double-click the right clavicle to select the entire foreleg, then click Copy Posture.
- 2  Go to frame 16, and click Paste Posture Opposite.
- 3   Copy then Paste Posture Opposite from the right foreleg in frame 7 to the left foreleg in frame 19, and from the right foreleg in frame 10 to the left foreleg in frame 22.
- 4 Repeat the previous three steps, but copying the left foreleg poses to the right foreleg at the same three frames.

Preview your work:

- 1  Click Play to see the animation.
The quadruped's forelegs now move in a plausible walk cycle.

- 2  Click Stop.

Save your work:

- Save the file as **my_quadraped_forelegs.max**.

Next

[Block the Steps for the Hind Legs](#) on page 1012



Block the Steps for the Hind Legs

Creating steps for the hind legs essentially repeats the work you did for the forelegs.





Set up the scene:

- Continue from the previous scene.

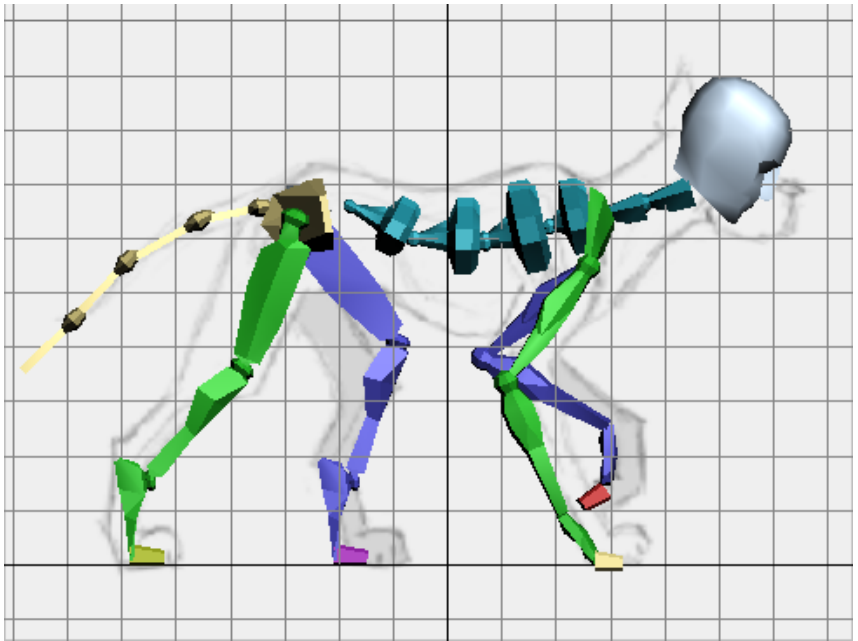
Start with the Down frames:

- 1   Go to frame 1. Use Move and Rotate to pose the hind legs in the Down pose, using the reference sketch as a guide.



- 2   Set a sliding key for each foot.
- 3  Double-click the right thigh to select the whole hind leg.
- 4  Go to frame 25, then click Paste Posture.
- 5  Go to frame 13, then click Paste Posture Opposite.
- 6 Repeat steps 3 to 5 for the left leg.

Add the intermediate poses:

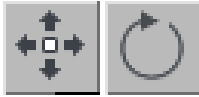

1 Post the legs at the intermediate frames, as follows:

■ Frame 4, Passing

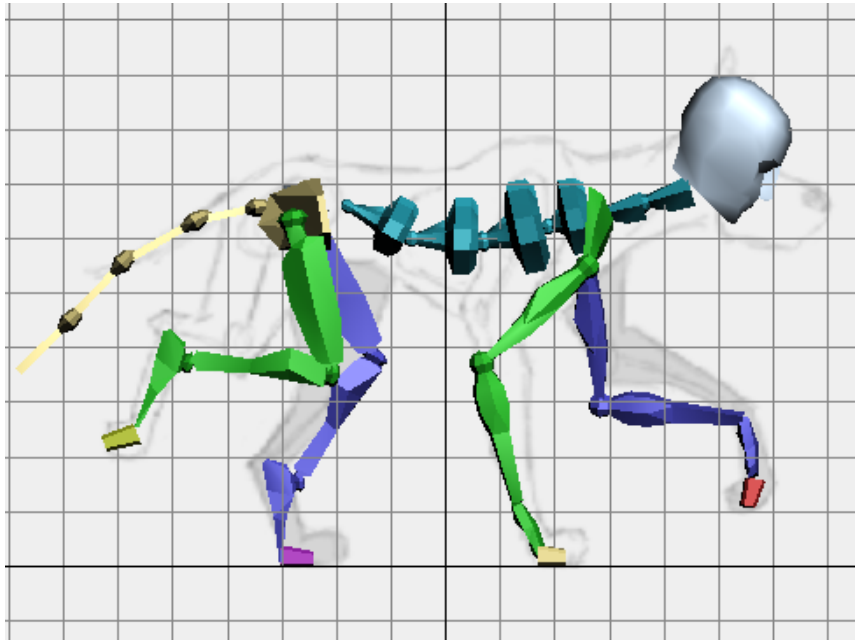

■ Frame 7, Up

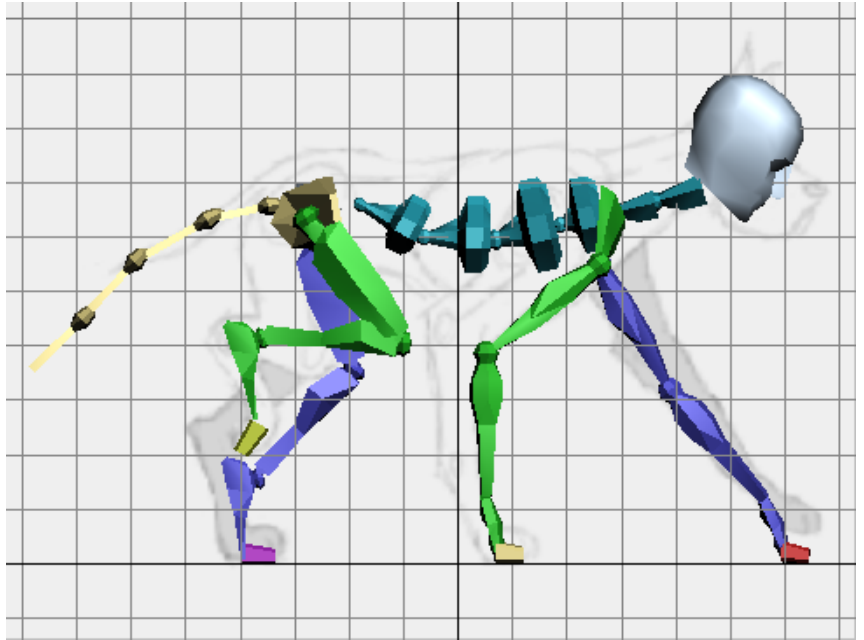

■ Frame 10, Contact

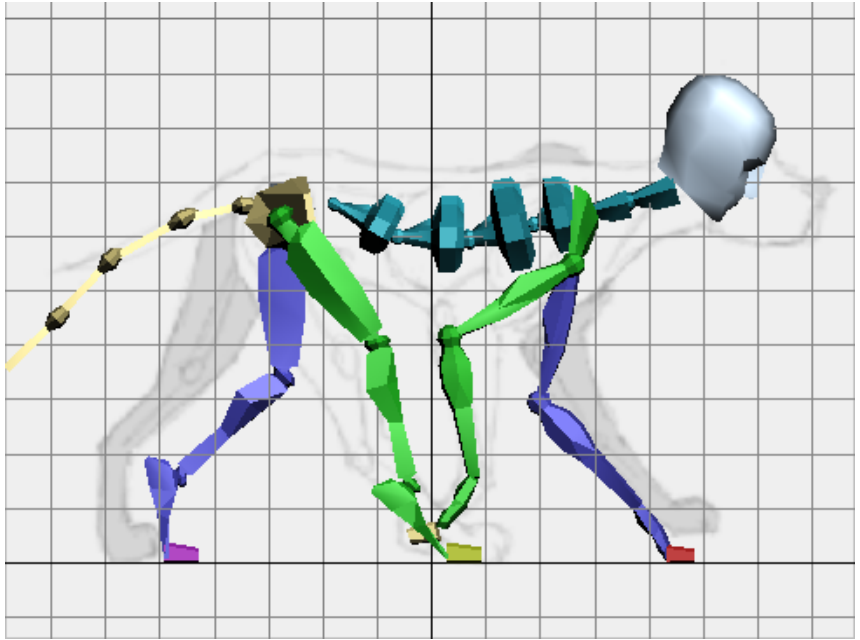

NOTE For now, don't worry if the front and hind feet overlap in space at the hind legs' crossing pose. You will fix this later.

- 2   Set sliding keys for the feet.

Copy poses to the second half of the walk cycle:

-  For each hind leg, copy the intermediate poses to the opposite hind leg in the second half of the walk cycle, as follows:
- Frame 4 to frame 16
 - Frame 7 to frame 19
 - Frame 10 to frame 22

Preview your work:

- 1  Click Play to see the animation.

Now all the legs move in a plausible walk cycle. The effect is still a bit stiff and mechanical: you will correct that in the following lesson.

TIP If the animation looks too jerky at points, you can stop playback, adjust poses (Auto Key should still be on), and scrub the time slider to see how it appears. The goal is a smooth-looking walk, but it doesn't have to be perfect.

- 2  Click Stop.

Save your work:

- Save the file as **my_quadraped_alllegs.max**.

Next

[Add Weight Shifts and Spine Movement](#) on page 1017



Add Weight Shifts and Spine Movement

For a more realistic walk, the quadruped's hips and shoulders need to move up and down as the weight of the animal shifts from leg to leg. You will create a layer that contains this animation. Using a new layer allows you to compare the original animation with the newly created keys. When you are satisfied with the new animation, you can collapse layers to integrate the old and new animation.

Set up the scene:





-  Continue from the previous lesson, or navigate to the `\animation\character_animation\quadraped` folder, and open `quadraped_walk_3.max`.
If a dialog asks whether you want to use the scene's Gamma and LUT settings, accept the scene Gamma settings, and click OK.

Create a layer for the hip and shoulder motion:

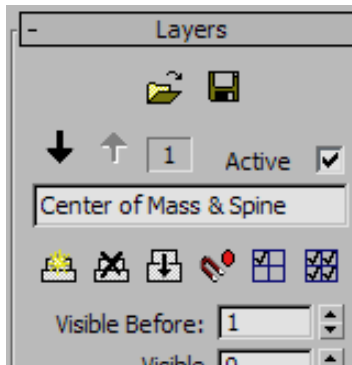
- 1   Select any part of the quadruped, go to the Motion panel, and open the Layers rollout.

- 2  On the Layers rollout, click Create Layer. Name the new layer **Center of Mass & Spine**.



- 3     Also on the Layers rollout, in the Retargeting group, turn on the retargeting buttons for all four legs. Turn on IK Only as well.



These controls preserve the IK constraints from the animation on the base layer. Without them, moving the quadruped's center of mass (COM) would simply translate the entire quadruped, disregarding the sliding keys you created earlier to control the feet.

- 4 Click Update.
If you select a foot, you can see that the sliding keys now appear in the Track Bar for this layer.

Create movement for the hips:

-  On the Motion panel, open the Track Selection rollout. Click Body Vertical to turn it on. This selects the COM, as well. Because the quadruped is walking in place, you need to adjust only the vertical position of the COM.

-  Go to frame 1. Turn on Auto Key, then move the COM down slightly (frame 1, as you might recall, is a Down pose).

NOTE When you work with layers, the viewport feedback isn't fully interactive: as you move the COM, the feet descend below the ground plane. After you release the mouse, 3ds Max recalculates IK and the feet snap into the position where they should be.

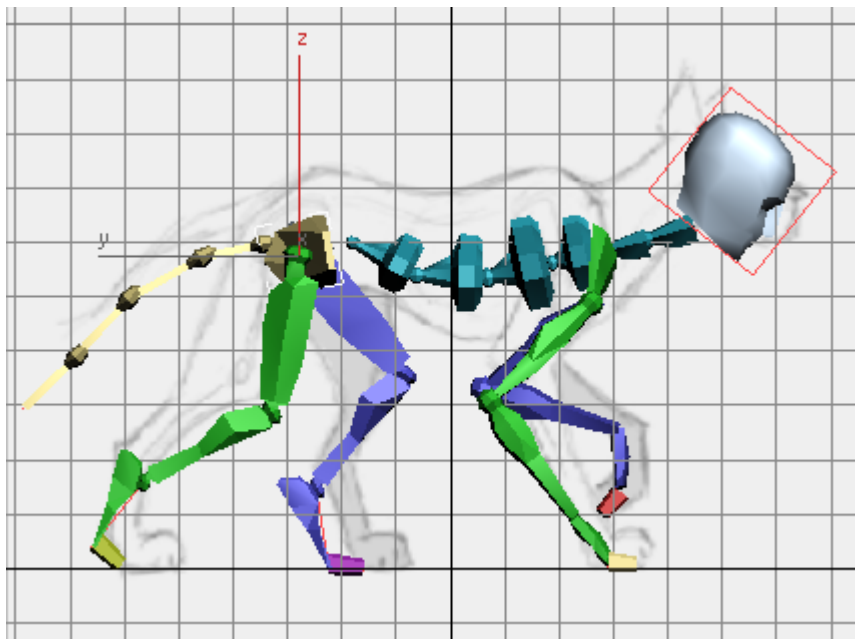

Lowered COM for the Down pose

As you animate on the *Center of Mass & Spine* layer, viewports show the original animation as a red stick figure with a box for a head.

- 3 On the Track Bar Shift+drag the new COM key to make a copy of it at frame 13 and frame 25, the other two Down frames in this cycle.



- 4 Go to frame 7, the Up state, and move the COM to a point that is higher than the original animation.

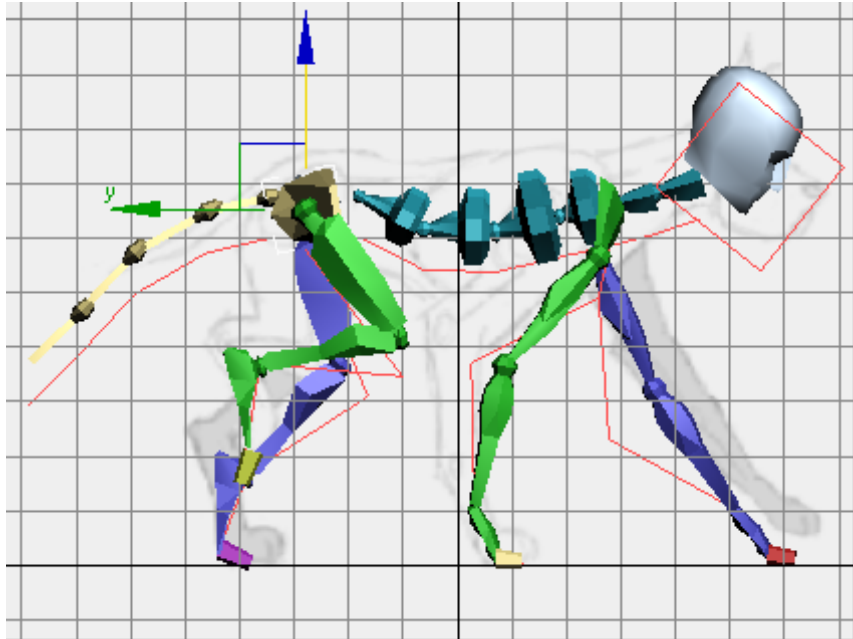

Raised COM for the Up pose

IMPORTANT When you raise the COM, try to make sure that the limbs are not extended too far: if they are fully extended, then Biped tends to generate abrupt motion, which doesn't look good or natural.

- 5 Shift+drag the new key from frame 7 to create a copy at frame 19.



- 6 Go to frame 10, the first Contact pose for the hind legs, and move the COM to a vertical position midway between its heights for the Down and Up poses.

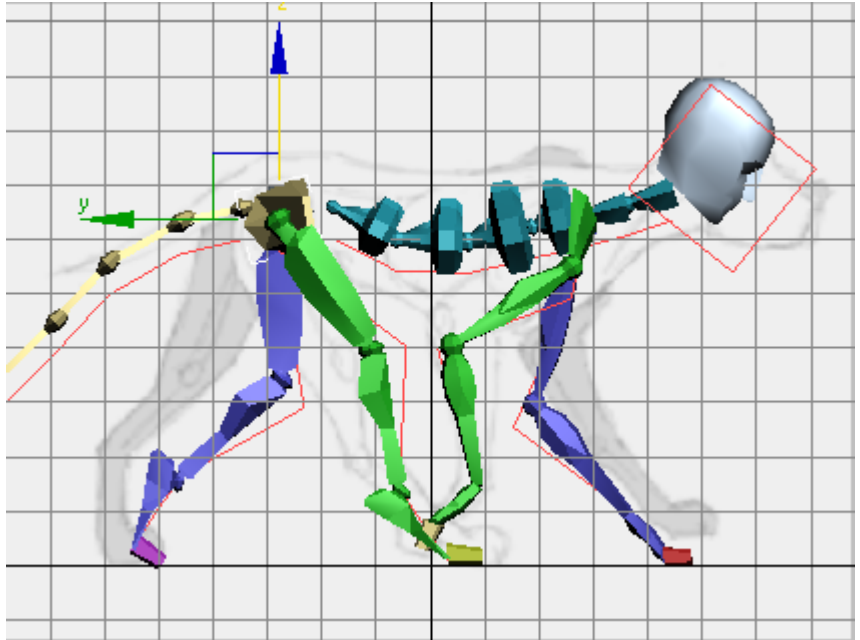

- 7 Shift+drag the new key from frame 10 to create a copy at frame 22.
If you scrub the time slider or play the animation, you can see that the hips now bob up and down in a more convincing version of a walk. The shoulders and spine still seem rigid.

Create movement for the shoulders:

- 1  Go to frame 1. Make sure Auto Key is still on.

- 2  Select the lowest spine link, *Bip01 Spine*, and rotate it up a bit (not too much).

- 3 Select the next spine link, *Bip01 Spine 1*, and rotate this link down a bit. The goal is to have the outline of the spine match the contour of the spine of the dog's body in the reference sketch.

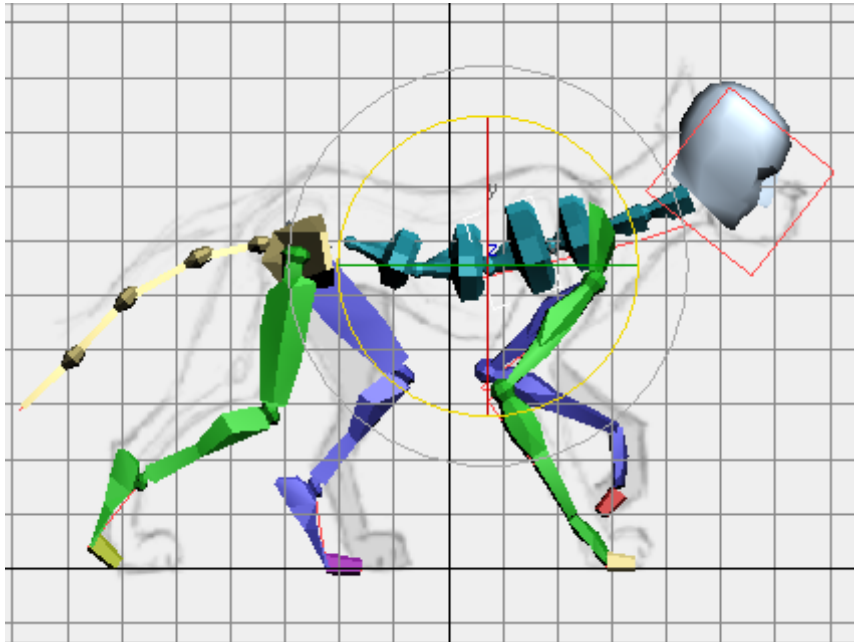

- 4 Shift+drag to copy the new key from frame 1 to frames 13 and 25.



- 5 Go to frame 7, the Contact pose for the forelegs, and repeat these adjustments to the lower two spine links. Again, you want to have the spine follow the dog's body in the sketches. At Contact for the forelegs, the dog's weight shifts from the pelvis to the shoulders.

In this step, you might want to adjust the third spine link, *Bip01 Spine 2*, down a little bit, as well.

After you adjust the spine, if the forefeet don't appear to be reaching the ground plane properly, go to the Layers rollout > Retargeting group, and click Update.

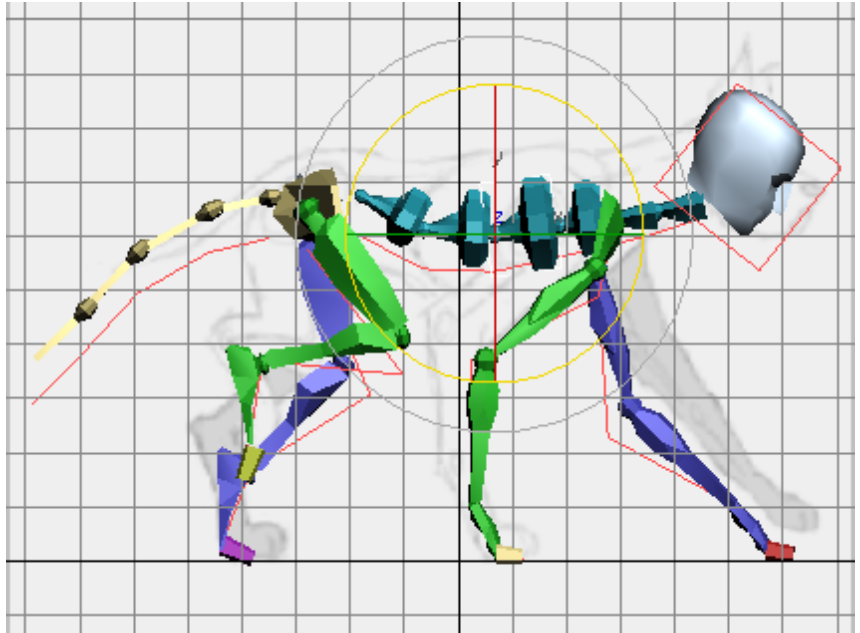

- 6 Shift+drag to copy the new key from frame 7 to frame 19.
If you scrub the Time Slider, you can see that the spine already has a more fluid movement.



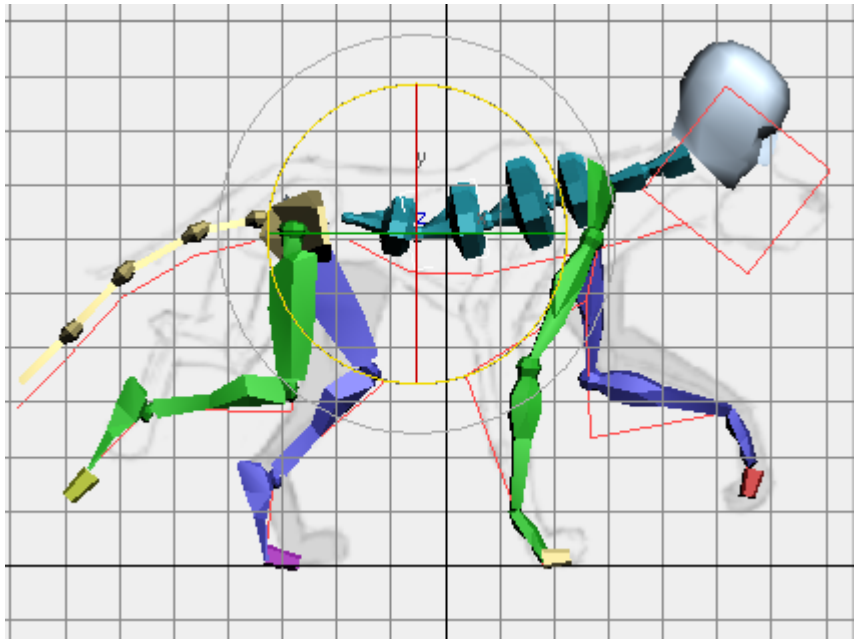

- 7 Go to frame 4, the Up pose for the forelegs. Again, rotate the spine links to follow the dog's body. For this pose, the spine should be a bit higher than the pelvis.





- 8 Shift+drag to copy the new key from frame 4 to frame 16.



With the spine movement added, the quadruped looks less like a robot and more like an animal walking.

Add some head movement:

- 1  Go to frame 1, and select the head of the quadruped.
- 2  On the Key Info rollout, click Set Key.
This sets a key for the head and the upper neck link, *Bip01 Neck1*.
- 3 Shift+drag the new key from frame 1 and copy it to frame 25, then copy it to frame 11 as well.

- 4   Select the lower neck link, *Bip01 Neck*, then click Set Key to set a key for it as well.
- 5 Shift+drag the neck key to copy it to frames 11 and 25, as you did for the head.

You've now set up a reference pose about which other head poses can move. Head movement is *secondary motion*. It's called "secondary" because the walk doesn't depend on it, and it doesn't affect the leg or body motion. However, secondary motion can add a great deal of life to an animation.

- 6   Go to frame 7. Make sure Auto Key is on, then rotate the neck and head upward slightly.

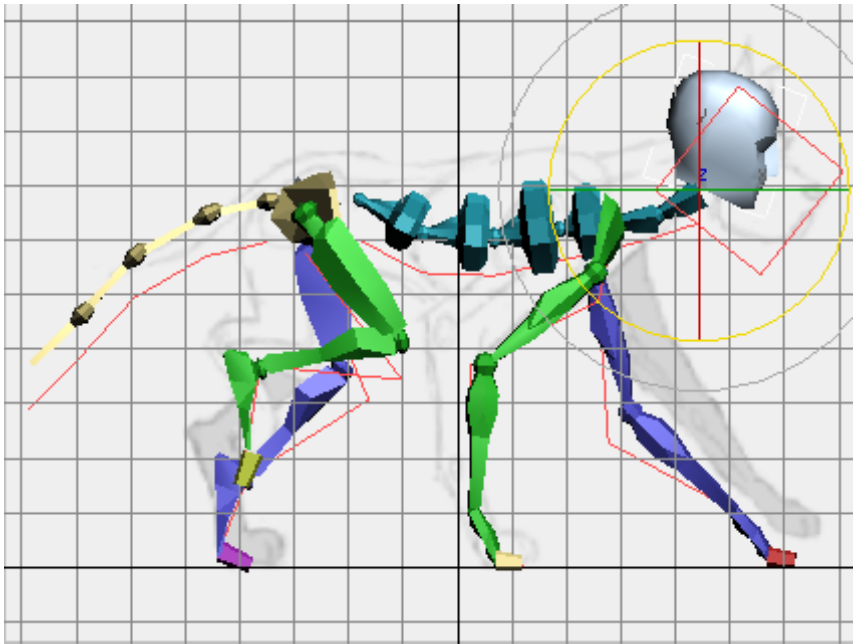

The idea is that in general, the dog looks where it is going when it's forelegs are in the Contact position.

- 7 Shift+drag the new key to copy it to frame 19.

- 8 Go to frame 11. Rotate the neck links so they are roughly parallel to the ground, and then rotate the head so it is looking slightly down.

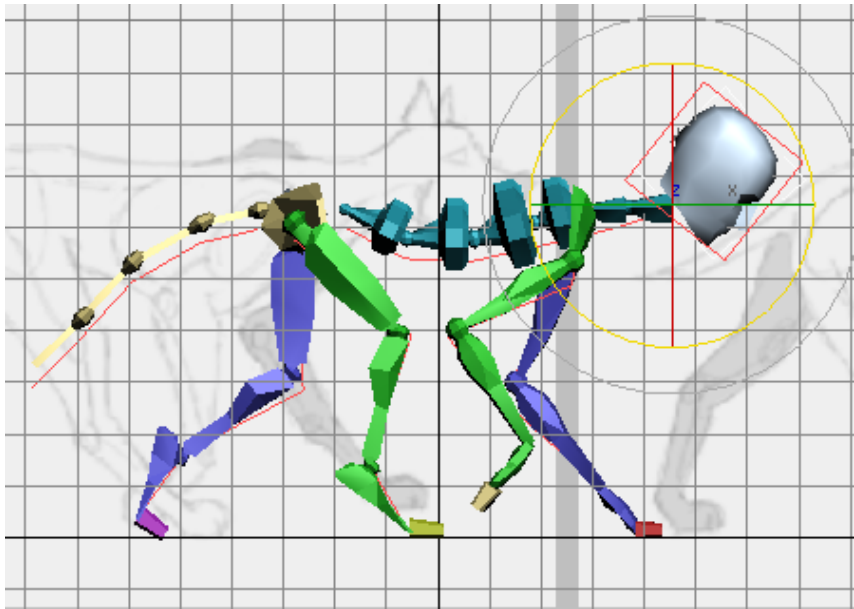

As you probably noticed, frame 11 comes one frame *after* the Down pose at frame 10. Secondary motion tends to lag a little behind primary motion. Also, setting keys slightly out of phase in this way helps keep the animation from appearing too mechanical.

- 9 Shift+drag the new key to copy it to frame 22.

Save your work:

- Save the file as **my_quadruped_legs_spine_head.max**.

Next



[Polish the Walk Cycle](#) on page 1027

Polish the Walk Cycle



Set up the scene:

-  Continue from the previous lesson, or navigate to the `\animation\character_animation\quadruped` folder, and open `quadruped_walk_4.max`.
If a dialog asks whether you want to use the scene's Gamma And LUT settings, accept the scene Gamma settings, and click OK.

Collapse the layers:

- 1   Select any part of the quadruped, then go to the Motion panel.
- 2  On the Layers rollout, click Collapse.
Now the scene contains only a single layer of Biped animation: the keys you created on the *Center of Mass & Spine* layer are transferred to the main timeline.

Smooth out the trajectories:

- 1  Click and Ctrl+click to select all four of the quadruped's feet.
- 2  Open the Curve Editor.
- 3 If you need to, pan the Controller window until you can see the tracks for all four feet. Expand the hierarchy if you need to, and Ctrl+click to select all four Transform tracks.



- 4 On the Track View status bar, turn on the Filter - Selected Tracks Toggle.

This simplifies the Controller window display by showing only selected tracks.

- 5 Make sure you can see all keys in the Function Curves window.

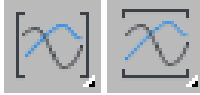

TIP You might have to click Zoom Horizontal Extents and Zoom Value Extents (on the Track View status bar) to see all the keys.

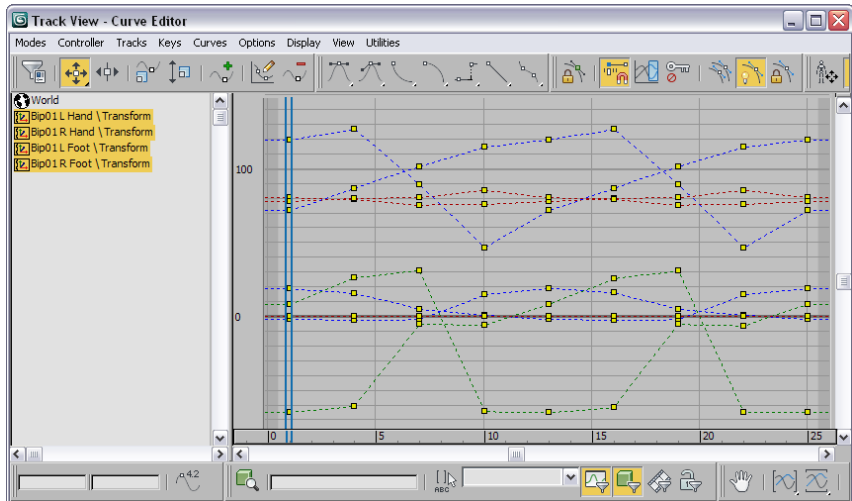

- 6 Drag a selection box to select all the keys in the animation.

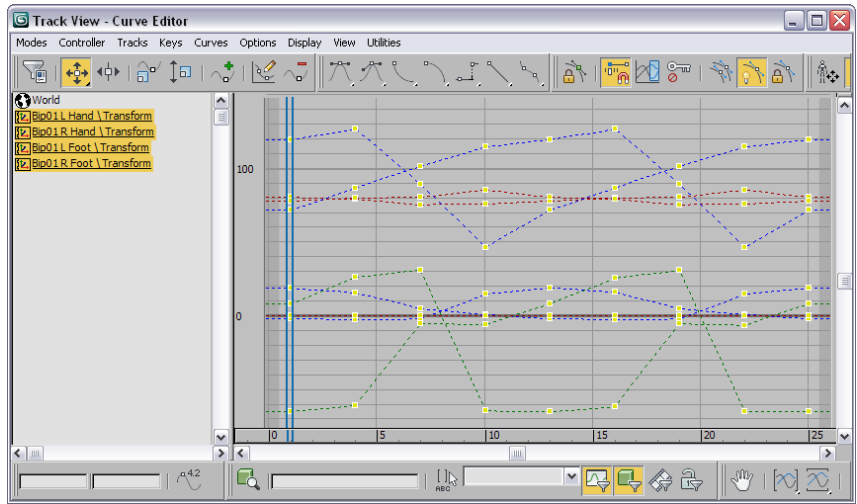

- 7  On the Track View toolbar (the Key Tangents toolbar), click Set Tangents To Smooth. Smooth tangents give the animation a more organic feel, making it less abrupt.

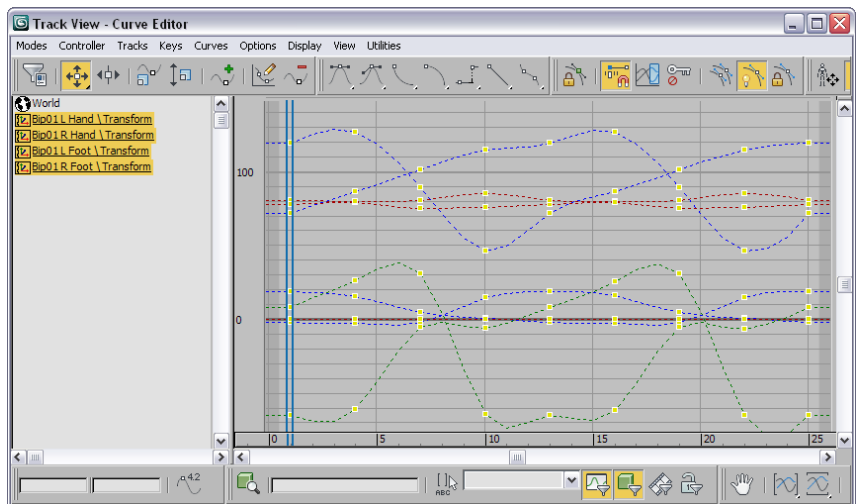

- 8 Close Track View.

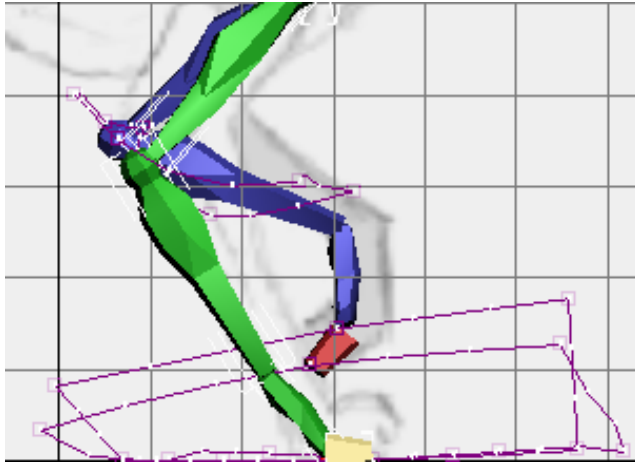

Trajectories of the dog's right forefoot and knee before smoothing

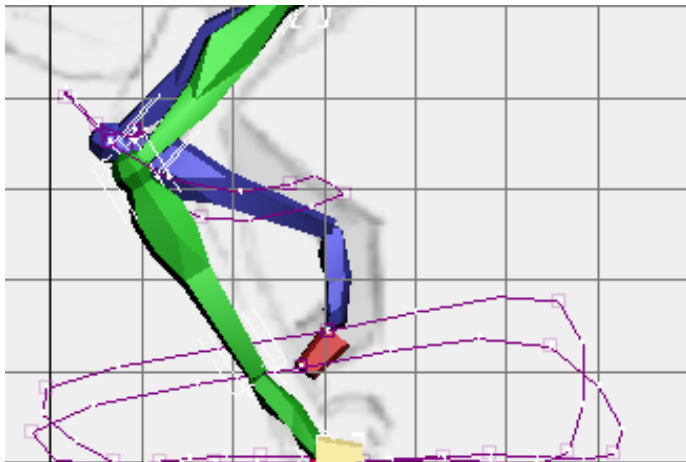



Trajectories of the dog's right forefoot and knee after smoothing

- 9  Play the animation.

The dog's walk is now much smoother, and feels more "integrated": more a single movement, and less a collection of individual movements.

Give the shoulder blades more freedom:

-   Turn on Auto Key. Go to frame 1, select the dog's shoulder blade (*Biped01 R Clavicle*), then rotate it up about **35** degrees in the local Z axis.

-  Make sure *only the shoulder blade/clavicle* is selected, then on the Copy/Paste rollout, click Copy Posture.

-  Click Paste Posture to paste the shoulder blade posture at frame 13.

- At frame 25, don't paste the posture, but rotate the shoulder blade up about **30** degrees.
Pasting the pose lifts the dog's foot off the ground, and we don't want that to happen.

-  Click Paste Posture Opposite to paste shoulder blade posture onto the left shoulder blade at frames 1, 13, and 25.

-  Switch to display all four viewports before you preview the animation.



We have been working mostly in the Left viewport, but this is a three-dimensional animation, and it helps to look at the motion from other points of view.

With more movement in the shoulder blades, the quadruped walk has more of a loping feel to it: a gait that we associate with wolves and larger dogs.

Add some side-to-side movement to the pelvis:

-  Maximize the Top viewport.

- 2  Make sure Auto Key is on.

- 3   On the main toolbar, turn on Angle Snap. Then at frame 1, rotate the pelvis to the dog's right, **15** degrees in the local Y axis.

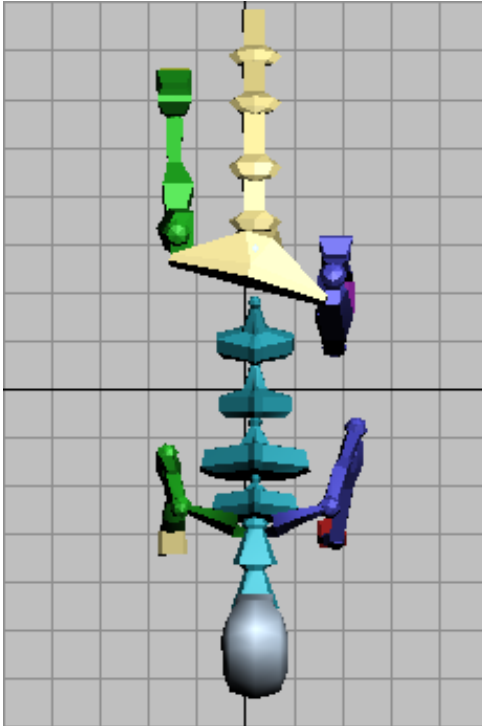

- 4  Go to frame 13. Rotate the pelvis to the dog's left: **-30** degrees in the local Y axis.

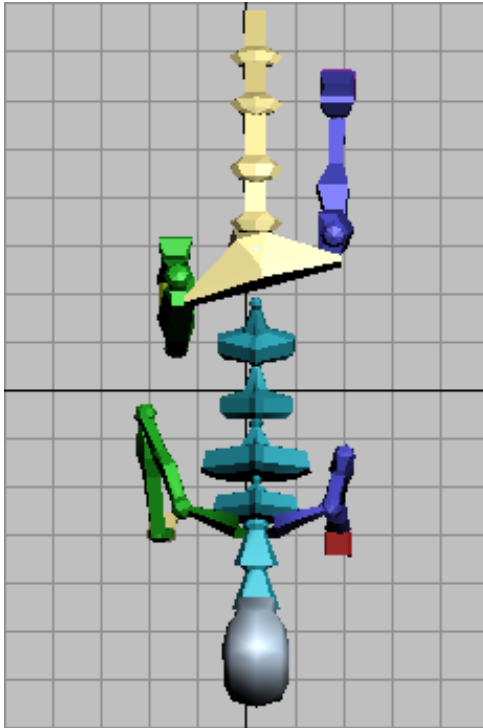

- 5 Finally, go to Frame 25, and restore the pelvis back to its frame 1 position: **30** in the local Y axis.

You can preview the animation, but the pelvis movement is really a basis for the spine movement, which you will add next.

Add side-to-side movement to the spine:



- 1 Make sure Auto Key and Angle Snap are both on.
- 2 Activate the Top viewport, if it isn't active already.
- 3 At frame 1, select the lowest link of the spine, *Bip01 Spine*.



- 4 Rotate *Bip01 Spine* to the dog's right, **15** degrees in the local Y axis.

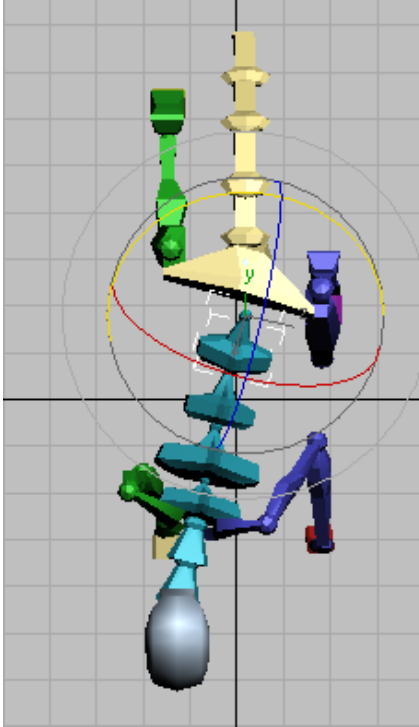

Notice that Biped maintains the head facing forward, which is what you want it to do.



- 5 Also at frame 1, rotate *Bip01 Spine02* **-10** degrees in the local Y axis, and then rotate *Bip01 Spine03* (the shoulders) **-15** degrees in the local Y axis.

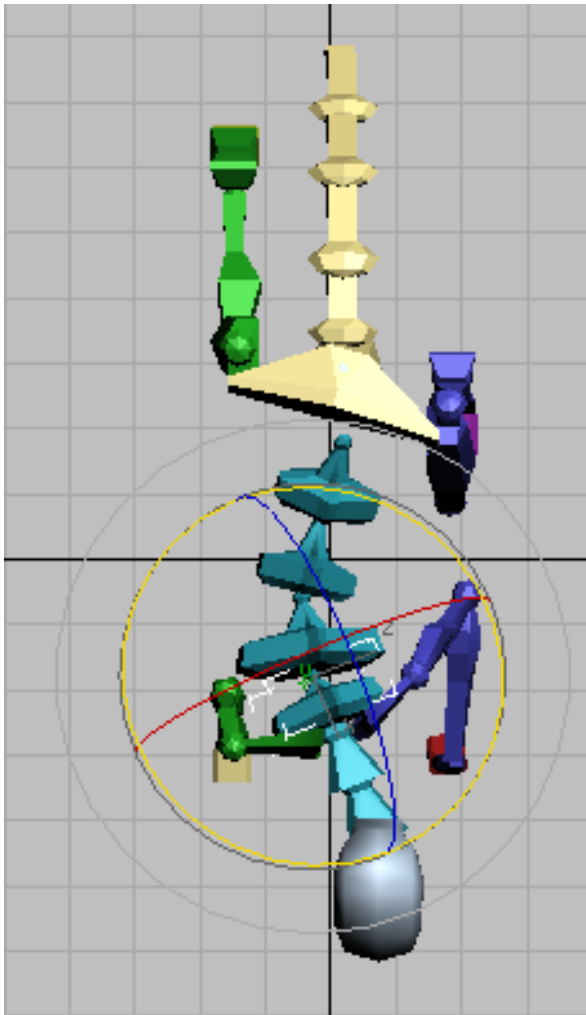

The spine describes an S-curve as the dog walks, with the shoulders rotating in the opposite direction from the hips.

WARNING Don't use Page Up or Page Down to select spine links. This select other biped parts as well, such as arm and leg links, and will generate unwanted animation.



- 6 Go to frame 13. Rotate the three spine links in the opposite direction: **-15** degrees in the local Y axis for *Bip01 Spine*; **10** degrees for *Bip01 Spine02*; and **15** degrees for the shoulders, *Bip01 Spine03*.

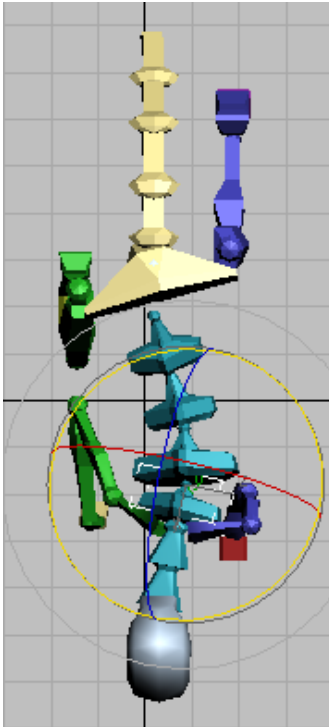



Because of other Biped keys, the spine returns to a straight posture by frame 5, so you don't have to "overcompensate" the rotation value as you did for the hips.

- 7 Finally, go to frame 25 and rotate the spine to its frame 1 position: **15** degrees in the local Y axis for *Bip01 Spine*; **-10** degrees for *Bip01 Spine02*; and **-15** degrees for the shoulders, *Bip01 Spine03*

The last bit of movement to add is, appropriately, the tail, which mirrors the spine movement in a similar S-curve. Like head movement, tail movement is a secondary motion that doesn't affect the mechanics of the walk, but does give it greater realism.

Add side-to-side movement to the tail:

- 1   Make sure Auto Key and Angle Snap are both on.
- 2 Activate the Top viewport, if it isn't active already.
- 3 At frame 1, select the lowest link of the tail, *Bip01 Tail*.

- 4  Rotate *Bip01 Tail* to the dog's left, -15 degrees in the local Y axis.

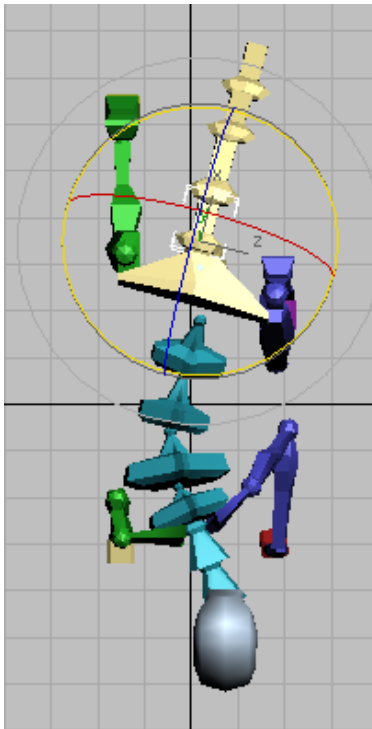

- 5  Rotate the remaining three tail links in the opposite direction, to counter the side-to-side motion of the spine.

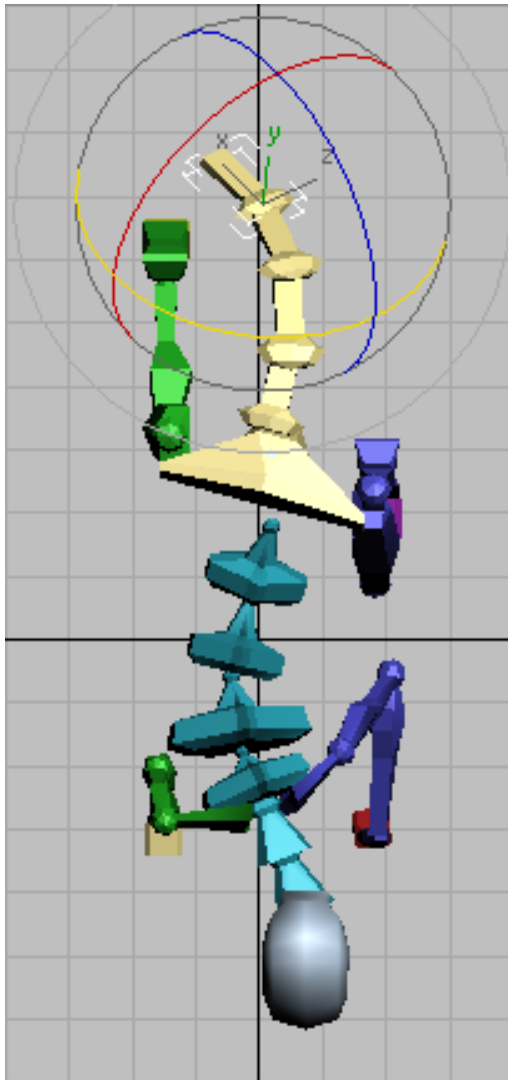

- 6 Go to frame 13 and as you did for the spine, rotate the tail links to mirror the frame 1 pose.

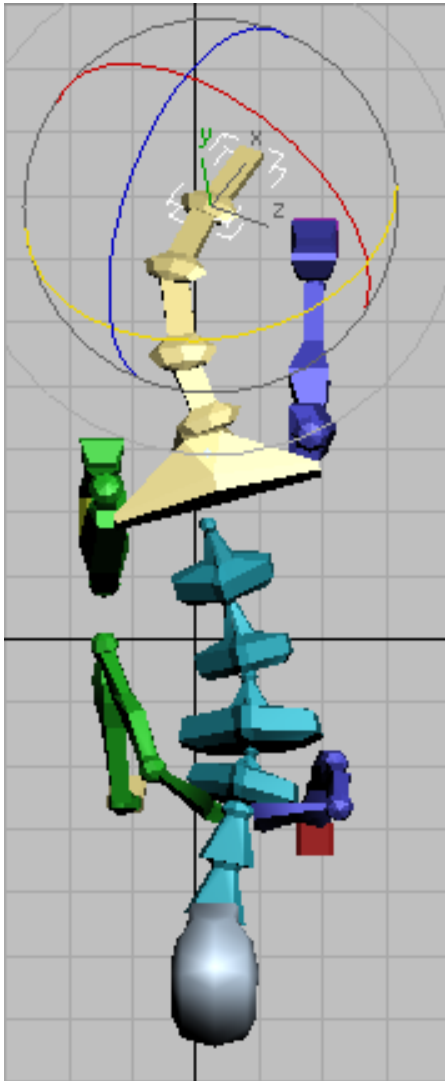

- 7  Go to frame 25 and restore the tail to its frame 1 pose.



TIP To save time, you can select all the tail links, copy their posture at frame 1, and paste the posture at frame 25.

- 8  Turn off Auto Key.

Correct the intersecting feet:

The last bit of “polish” to add to the dog’s walk is to remove the intersecting feet that was a result of simple footstep blocking.



- 1 Click the Maximize Viewport toggle so you can see all four viewports.
- 2 Drag the time slider to frame 10. At this point, the right forefoot intersects the right hind foot.

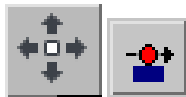
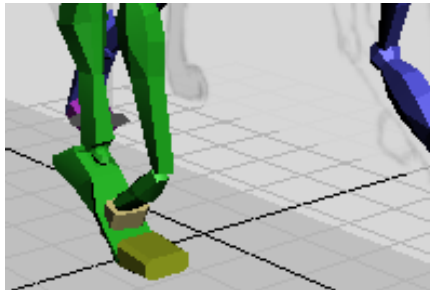

- 3 In the Left viewport, move the foot up and out of the way of the hind foot, and then click Set Sliding Key.

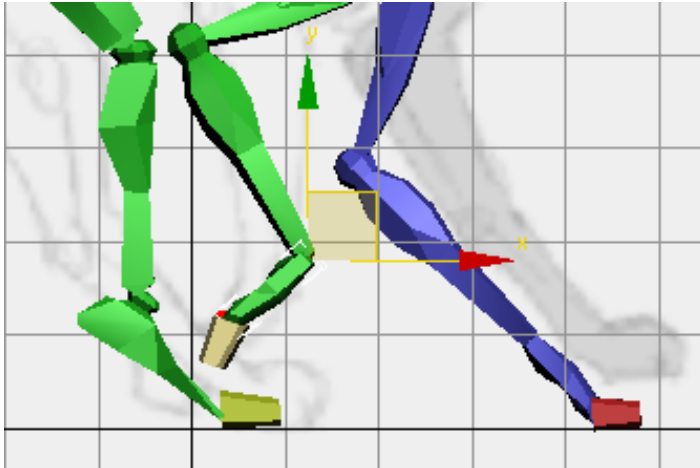

Now the forefoot lifts out of the way before the hind foot steps down. Scrub the time slider to make sure you've corrected the intersection: the forefoot should lift from the ground just before the hind foot descends.

- 4 Drag the time slider to frame 22.

Here there is the same problem with the left feet intersecting.

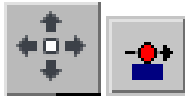

- 5 As you did for the right forefoot, move the left forefoot up and away from the descending hind foot, and then click Set Sliding Key.

Now neither the right nor left feet intersect during the walk.

Preview your work:

-  Now you've finished animating the dog's walk. Switch to all four viewports, and play the animation. Stop playback when you're done.

Save your work:

- Save the file as **my_quadruiped_completedwalk.max**.



To see a completed version of the animation, open *quadruped_walk_completed.max*.

Adding Extra Limbs

In this lesson, you'll add bones as appendages to a biped, creating a pair of wings, and learn how to animate them.

Note that the extra limbs become 3ds Max objects, and must be animated with rotations. They do not respond to Biped Figure mode or inverse kinematics.

Set up the lesson:

- 1 Reset 3ds Max.
- 2  Open *cs_tut_quad_wally_start.max* from `\character_animation\quadruped`.

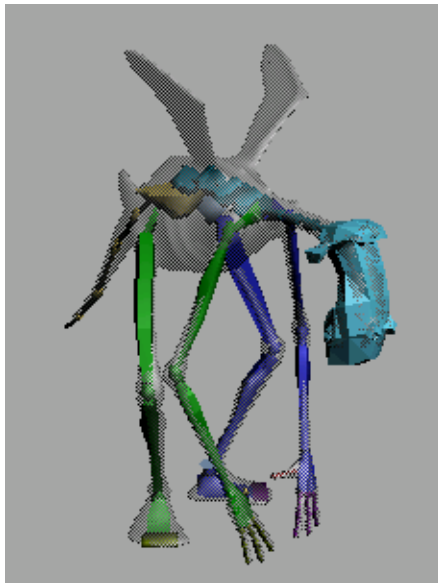



This file shows Wally in See-Through mode. He has wings, but no means of moving them. You'll remedy that in the next few procedures.

Add the wing bones:

-  1 In the Left viewport, use Region Zoom to focus on the area around the wings.

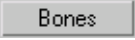

The view after zooming.

-   2 Open the Create panel, and click the Systems button.
-  3 **Bones** On the Object Type rollout, turn on Bones. In the Bone Parameters rollout > Bone Objects group, set the Width and Height values to **3.0**.



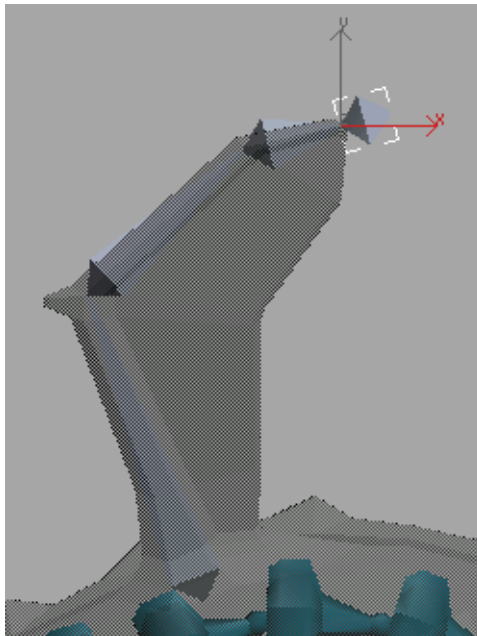

- 4 On the IK Chain Assignment rollout, make sure Assign To Children is turned off before making bones. Off is the default.
- 5 Add a set of four bones along the leading edge of the wing. See the following illustration. Create the three long bones, so the last bone is at the tip of the wing, then right-click to finish. The fourth bone will appear as a little knob at the end.



Bones along the leading edge of the wing.

- 6  Turn on Rotate. In the Front viewport, select *Bone01* and rotate it about **-35** degrees around the Z-axis.



- 7    Working between the Front and Left viewports, use Move, Rotate, and Scale to adjust the bones so they match the following illustrations.

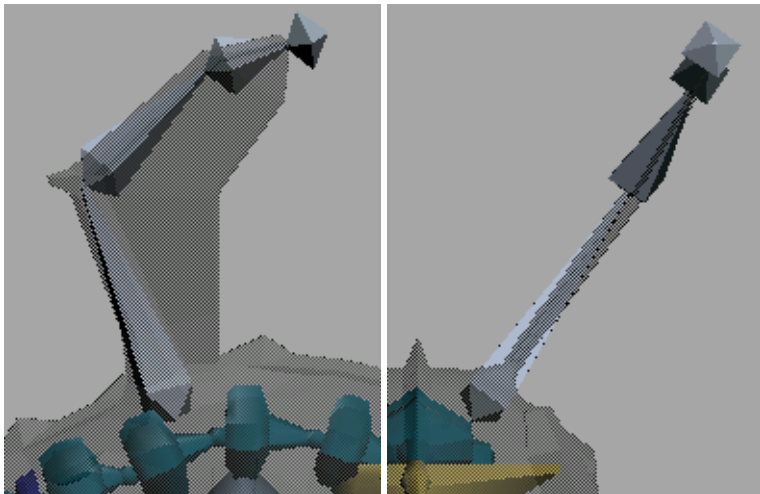



- 8 Save the scene as **MyWally01.max**.

Mirror the bones:

Now that one wing is created, you'll mirror the wing and set the proper IK solution.

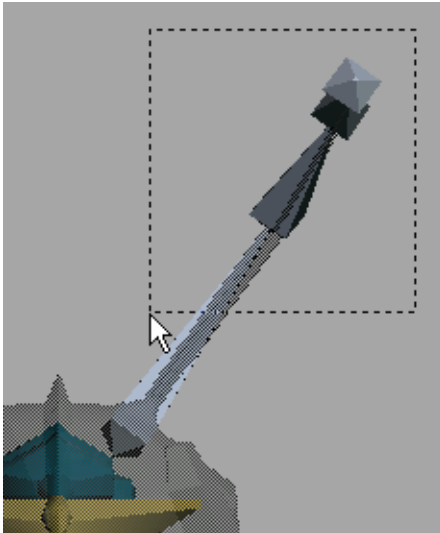
- 1 In the Front viewport, drag a selection window around the wing bones you just created.



- 2  On the main toolbar, click the Mirror button to display the Mirror dialog.
- 3 In the Mirror dialog, in the Clone Selection group, choose Copy. In the Mirror Axis group, set Offset to **-12.0** on the X axis. Click OK.
This creates four matching bones on the other side, named *Bone05* through *Bone08*.

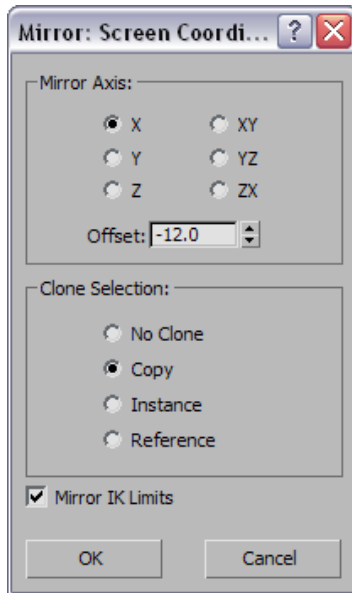

- 4 Select *Bone01*. This is the base bone on the right wing.
- 5 From the Animation menu, choose IK Solvers > HI Solver, and click the end bone, *Bone04*.

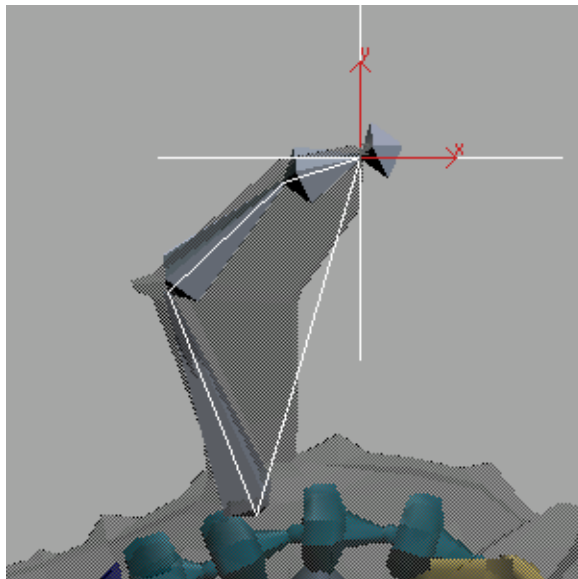

- 6 Select the base bone on the left wing.
- 7 Apply the HI Solver to this bone and click the end bone on the left wing.

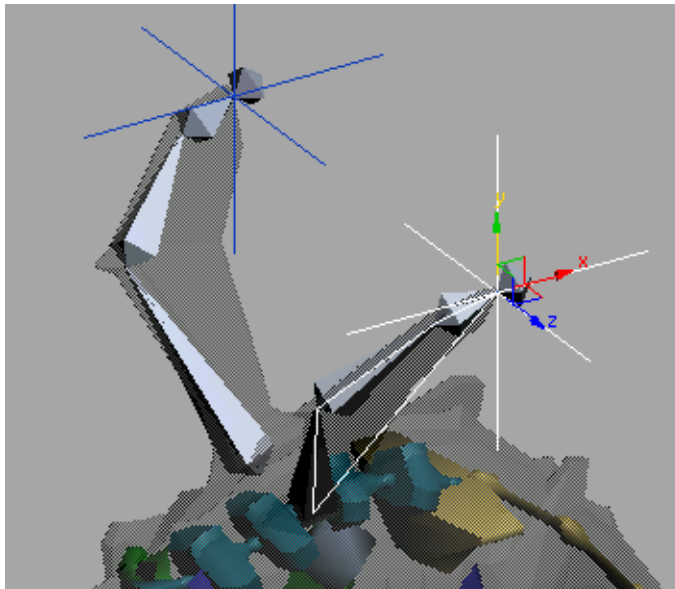

Both wings have IK solutions.

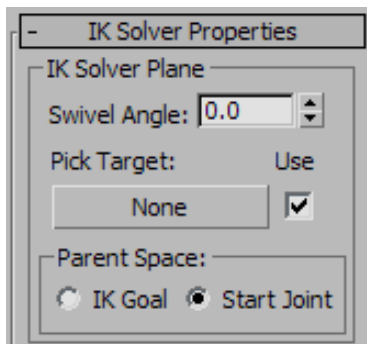

NOTE It's a good idea to test the bend by moving the end effectors. It might be necessary to adjust the Swivel Angle in the Motion panel > IK Solver Properties rollout > IK Solver Plane group.



-
- 8 Save the scene as **MyWally02.max**.

Add dummies to control the wings:

You'll now add two dummy objects to act as control handles for the wings.

- 1   Open the Create panel, and click the Helpers button.
- 2 Click Dummy. In the Top viewport, drag to create a small dummy object near the tip of the right wing.
- 3  In the Front viewport, move the dummy object up to the wing tip.

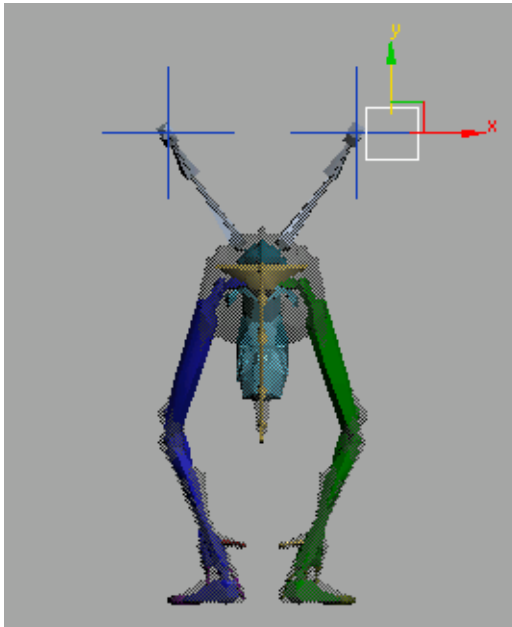

- 4 Hold down the Shift key and move a copy of the dummy over to the tip of the left wing.

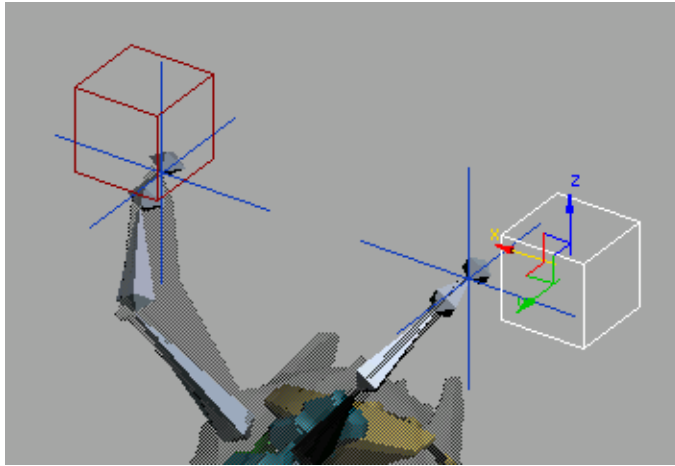

The dummies will be used as control handles instead of the end effectors.



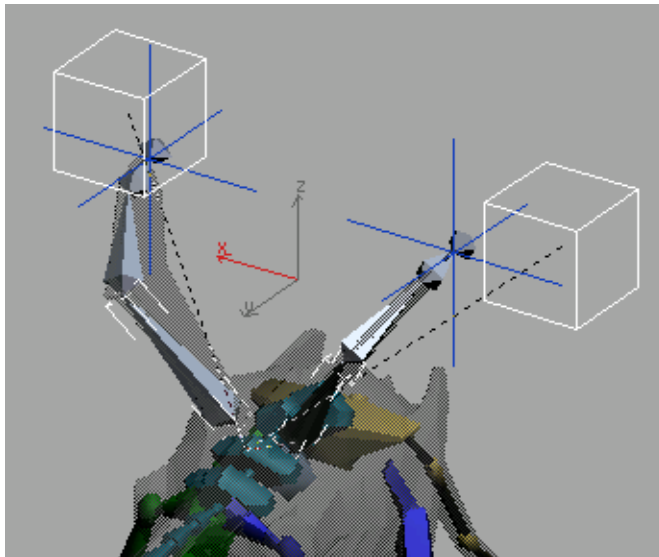

- 5 Select both dummy objects and the base bones of the left and right wing. On the main toolbar, turn on Select And Link, and then drag a link to *Wally Biped Spine2*.





If you move the biped, the wing bones and dummies will move along with the rest of the model.

NOTE After linking, you the bones might rotate out of alignment with the mesh. This is fixed by adjusting the Swivel Angle in the Motion panel > IK Solver Properties rollout > IK Solver Plane group.

- 6  Select *IK Chain01* and link it to *Dummy01*. Repeat this step by selecting *IK Chain02* and linking it to *Dummy02*.

- 7  Select *IK Chain01* and open the Motion panel.
- 8 In the IK Solver Properties rollout > IK Solver Plane group, adjust the value of the Swivel Angle for each IK solver again, if you need to.
- 9 Save the scene as **MyWally03.max**.

Animate the wings:

- 1  Move the time slider to frame 5, and turn on Auto Key.
- 2  From the Front viewport, select *Dummy01*. Move it down and to the right a little.

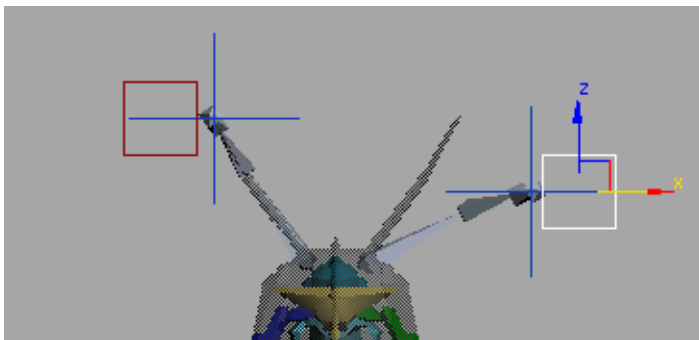

- 3 Move the time slider to frame 10, and move *Dummy01* down and a little to the left.

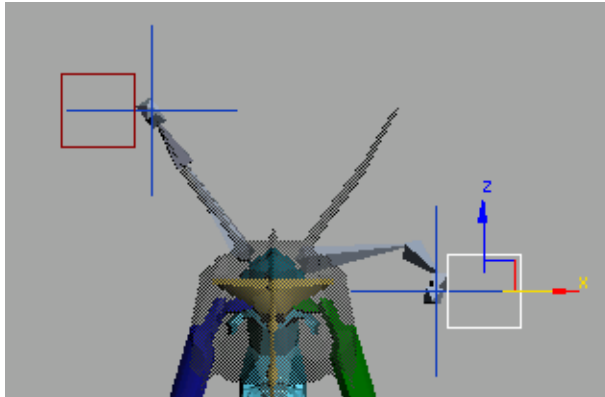

- 4 On the time bar, select the key at frame 5. Hold down the Shift key and drag a copy to frame 15. Repeat this step with the key at frame 0, and drag it to frame 20.
- 5 Repeat the previous steps with *Dummy02*.
When you're done, you've animated Wally flapping his wings.
- 6 To see a finished product, open *cs_tut_quad_wally_final.max*, or view `\sceneassets\renderassets\wallyshow320.avi`. It shows a version of Wally that flaps his wings and lifts off.



Summary

The lessons about the walking dog showed that in essence, a quadruped walk cycle combines two biped walk cycles. They demonstrated the ForeFeet toggle that enables hands to behave as feet, with sliding keys on the ground plane. They also showed one way to smooth tangents for a better-integrated animation.

The lesson about adding wings to Wally showed how you can add limbs to a biped (they don't have to be wings) by constructing them of independent bones, then making them children of the biped skeleton. You can control each additional limb by giving it an IK solver, and using a dummy to control the solver, for convenience.